



This manual contains important warnings and information.
READ AND KEEP FOR REFERENCE.

INSTRUCTIONS

First choice when
quality counts.™

1:1 RATIO

TRITON™ 308 Diaphragm Pump

115 psi (0.8 MPa, 8 bar) Maximum Fluid Working Pressure

115 psi (0.8 MPa, 8 bar) Maximum Air Input Pressure

Part No. 233500 Aluminum Pump, Series A

Part No. 233501 Stainless Steel Pump, Series A

US and Foreign Patents Pending

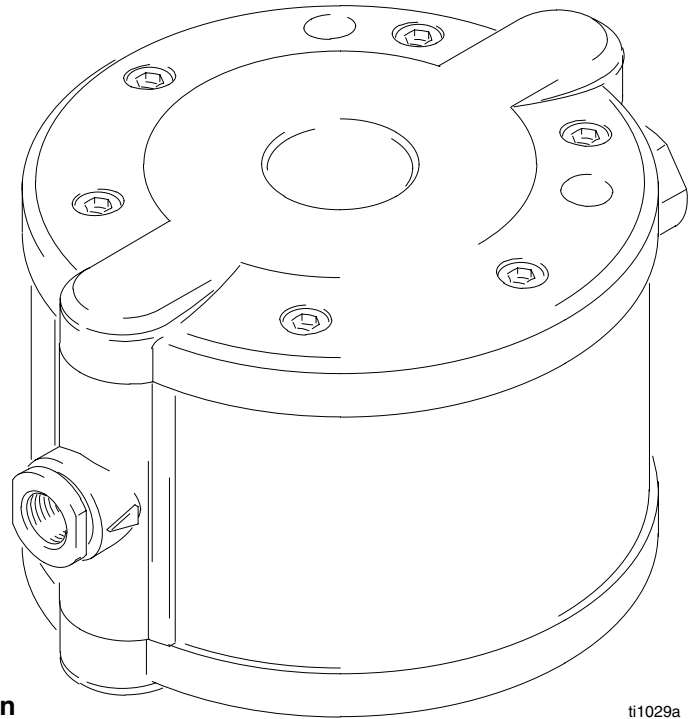

Part No. 233501 Shown

ti1029a

GRACO INC. P.O. BOX 1441 MINNEAPOLIS, MN 55440-1441

©COPYRIGHT 2001, GRACO INC.

Graco Inc. is registered to I.S. EN ISO 9001

Table of Contents

Safety Warnings	3
Installation	6
Operation	11
Maintenance	12
Troubleshooting	12
Service	
Remove the Fluid and Side Covers	14
Ball Check Repair	16
Diaphragm Repair	17
Air Valve Repair	18
Shaft Repair	20
Parts	22
Technical Data	24
Dimensions	25
Graco Standard Warranty	26
Graco Toll-Free Phone Numbers	26

Symbols

Warning Symbol



This symbol alerts you to the possibility of serious injury or death if you do not follow the instructions.

Caution Symbol



This symbol alerts you to the possibility of damage to or destruction of equipment if you do not follow the instructions.

WARNING



INSTRUCTIONS



EQUIPMENT MISUSE HAZARD

Equipment misuse can cause the equipment to rupture, malfunction, or start unexpectedly and result in a serious injury.

- This equipment is for professional use only.
- Read all instruction manuals, tags, and labels before operating the equipment.
- Use the equipment only for its intended purpose. If you are not sure, call your Graco distributor.
- Do not alter or modify this equipment. Use only genuine Graco parts and accessories.
- Check equipment daily. Repair or replace worn or damaged parts immediately.
- Do not exceed the maximum working pressure of the lowest rated component in your system. This equipment has a **115 psi (0.8 MPa, 8 bar) maximum working pressure at 115 psi (0.8 MPa, 8 bar) maximum incoming air pressure.**
- Use fluids and solvents which are compatible with the equipment wetted parts. Refer to the **Technical Data** section of all equipment manuals. Read the fluid and solvent manufacturer's warnings.
- **Aluminum pumps only:** Never use 1,1,1-trichloroethane, methylene chloride, other halogenated hydrocarbon solvents or fluids containing such solvents in pressurized aluminum equipment. Such use could result in a chemical reaction, with the possibility of explosion.
- Do not use hoses to pull equipment.
- Route hoses away from traffic areas, sharp edges, moving parts, and hot surfaces. Do not expose Graco hoses to temperatures above 180°F (82°C) or below -40°F (-40°C).
- Wear hearing protection when operating this equipment.
- Comply with all applicable local, state, and national fire, electrical, and safety regulations.

WARNING



FIRE AND EXPLOSION HAZARD

Improper grounding, poor air ventilation, open flames, or sparks can cause a hazardous condition and result in fire or explosion and serious injury.

- Ground the equipment. Refer to **Grounding** on page 7.
- If there is any static sparking or you feel an electric shock while using this equipment, **stop pumping immediately**. Do not use the equipment until you identify and correct the problem.
- Provide fresh air ventilation to avoid the buildup of flammable fumes from solvents or the fluid being pumped.
- Keep the work area free of debris, including solvent, rags, and gasoline.
- Electrically disconnect all equipment in the work area.
- Extinguish all open flames or pilot lights in the work area.
- Do not smoke in the work area.
- Do not turn on or off any light switch in the work area while operating or if fumes are present.
- Do not operate a gasoline engine in the work area.

WARNING



PRESSURIZED FLUID HAZARD

Spray from the gun, hose leaks, or ruptured components can splash fluid in the eyes or on the skin and cause serious injury.

- Do not stop or deflect fluid leaks with your hand, glove, or rag.
- Follow the **Pressure Relief Procedure** on page 11 before cleaning, checking, or servicing the equipment.
- Tighten all fluid connections before each use.
- Check the hoses, tubes, and couplings daily. Replace parts immediately if worn, damaged, or loose. Permanently coupled hoses cannot be repaired.



TOXIC FLUID HAZARD

Hazardous fluids or toxic fumes can cause a serious injury or death if splashed in the eyes or on the skin, swallowed, or inhaled.

- Know the specific hazards of the fluid you are using. Read the fluid manufacturer's warnings.
- Store hazardous fluid in an approved container. Dispose of the hazardous fluid according to all local, state, and national guidelines.
- Wear appropriate protective clothing, gloves, eyewear, and respirator.
- If the diaphragm fails, the fluid is exhausted along with the air.

Installation

General Information

- Fig. 2 shows a wall mounted HVLP spray application. It is only a guide for selecting and installing system components. Contact your Graco distributor for assistance in planning a system to suit your needs.
- Always use Genuine Graco Parts and Accessories, available from your Graco distributor. If you supply your own accessories, be sure they are adequately sized and pressure rated for your system.
- Use a compatible, liquid thread sealant on all male threads. Tighten all connections firmly to avoid air or fluid leaks.
- Reference numbers and letters in parentheses refer to the callouts in the figures and the parts lists on pages 22–23.
- *In a spray system, ventilate the spray booth.*

WARNING

FIRE AND EXPLOSION HAZARD

To prevent hazardous concentrations of toxic and/or flammable vapors, spray only in a properly ventilated spray booth. Never operate the spray gun unless ventilation fans are operating.

Check and follow all of the national, state, and local codes regarding air exhaust velocity requirements.

WARNING



TOXIC FLUID HAZARD

Hazardous fluid or toxic fumes can cause serious injury or death if splashed in the eyes or on the skin, inhaled, or swallowed.

1. Read **TOXIC FLUID HAZARD** on page 5.
2. Use fluids and solvents which are compatible with the equipment wetted parts. Refer to the **Technical Data** section of all equipment manuals. Read the fluid and solvent manufacturer's warnings.

Mounting the Pump

- Mount the pump in a well-ventilated area, with sufficient clearance on all sides for operator access and servicing.
- Be sure the mounting can support the weight of the pump, hoses, and accessories, as well as the stress caused during operation.
- The pump may be mounted vertically or horizontally. Be sure the pump is level in all directions.
- Wall, pail, stand, or portable cart mounting kits are available from Graco. For other mountings, be sure the pump is adequately secured. The pump has two mounting holes for 0.35 in. (9 mm) screws. See the Dimension drawing on page 25.

Installation

Grounding

⚠ WARNING	
	FIRE AND EXPLOSION HAZARD This pump must be grounded. Before operating the pump, ground the system as explained below. Also read the section FIRE AND EXPLOSION HAZARD on page 4.

To reduce the risk of static sparking, ground the pump and all other equipment used or located in the pumping area. Check your local electrical code for detailed grounding instructions for your area and type of equipment.

Ground all of this equipment:

- *Pump:* Attach a ground wire (Y) to the pump's grounding clamp (35) and secure with the screw, as shown in Fig. 1. Connect the clamp end of the ground wire to a true earth ground. Order Part No. 238909 Ground Wire and Clamp.

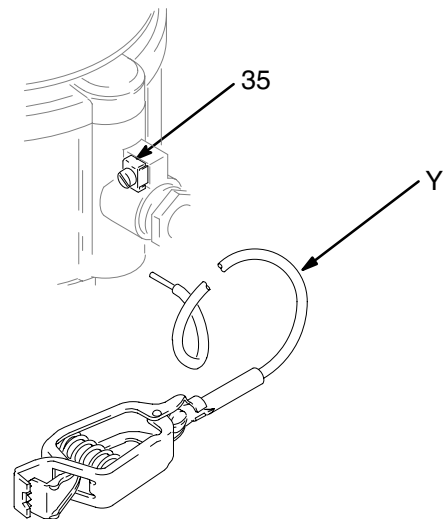

ti1030a

Fig. 1

- *Air and fluid hoses:* Use only electrically conductive hoses.
- *Air compressor:* Follow the manufacturer's recommendations.
- *Solvent pails used when flushing:* Follow your local code. Use only metal pails, which are conductive. Do not place the pail on a non-conductive surface, such as paper or cardboard, which interrupts the grounding continuity.
- *Fluid supply container:* Follow your local code.

Installation

Air Line

WARNING

A bleed-type master air valve (B) is required in your system to relieve air trapped between this valve and the pump. See Fig. 2. Trapped air can cause the pump to cycle unexpectedly, which could result in serious injury, including splashing in the eyes or on the skin, injury from moving parts, or contamination from hazardous fluids.

1. Install the air line accessories as shown in Fig. 2. Mount these accessories on the wall or on a bracket. Be sure the air line supplying the accessories is electrically conductive.
 - a. The fluid pressure can be controlled in two ways. On the air side, use the pump air regulator (F). On the fluid side, install a fluid regulator (H) near the pump fluid outlet.
 - b. Locate a bleed-type master air valve (B) close to the pump, to relieve trapped air. See the **WARNING** at left. Locate another air valve (E) upstream from all air line accessories, to isolate them during cleaning and repair.
 - c. Install an air line filter (D) to remove harmful contaminants such as dirt, moisture, and oil from the compressed air supply.
2. The air valve does not require lubrication.
3. Install an electrically conductive, flexible air hose (C) between the accessories and the 1/4 npt(f) pump air inlet (T). Use a minimum 1/4" (6.3 mm) ID air hose. Screw an air line quick disconnect coupler (V) onto the end of the air hose and screw the mating fitting into the pump air inlet snugly. Do not connect the coupler to the fitting yet.

Installation

Wall Mount HVLP Spray Installation Shown

KEY

- A TRITON 308 Pump
- B Bleed-type master air valve (required for pump)
- C Air supply line
- D Air line filter
- E Air line shutoff valve
- F Pump air regulator
- G Gun air regulator (used in spray system only)
- H Fluid pressure regulator (used in spray system only)
- J Drain/circulation valve
- K Drain tube
- L Suction tube
- M Pump fluid inlet, 3/4 npt(f)
- N Pump fluid outlet, 3/8 npt(f)
- P Fluid hose (shown connected to gun in spray system)
- R Gun air hose (used in spray system only)
- S Spray gun (used in spray system only)
- T Pump air inlet, 1/4 npt(f)
- U Agitator (used in spray system only)
- V Air line quick disconnect
- Y Ground wire

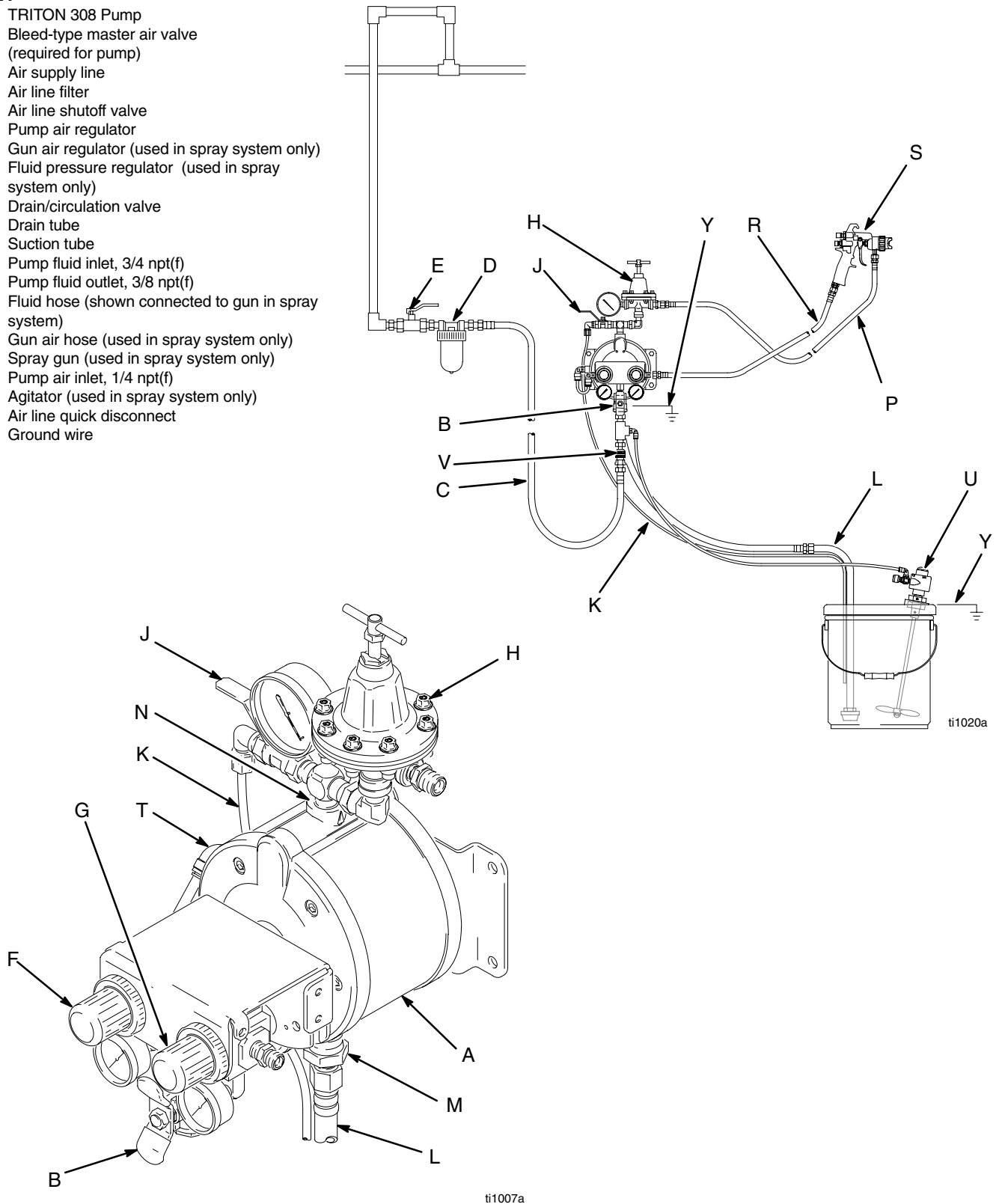

Fig. 2

Installation

Fluid Suction Line

- The pump fluid inlet (M) is 3/4 npt(f). Screw the suction line (L) into the pump inlet snugly. Use a compatible liquid thread sealant on connections to prevent air from getting into the fluid line.
- Do not pressure feed this pump.
- See the **Technical Data** on page 24 for maximum suction lift.
- Use an agitator (U) to prevent fluid from settling out. Part No. 245081 Agitator Kit (accessory) is available.

Fluid Outlet Line

WARNING

A fluid drain valve (J) is required in your system to relieve pressure in the hose if it is plugged. See Fig. 2. The drain valve reduces the risk of serious injury, including splashing in the eyes or on the skin, or contamination from hazardous fluids when relieving pressure. Install the valve close to the pump fluid outlet. To use the valve as a circulation valve, connect a tube (K) between the valve and pail.

CAUTION

Some systems may require installation of a pressure relief valve at the pump outlet to prevent overpressurization and rupture of the pump or hose.

Thermal expansion of fluid in the outlet line can cause overpressurization. This can occur when using long fluid lines exposed to sunlight or ambient heat, or when pumping from a cool to a warm area (for example, from an underground tank).

Overpressurization can also occur if the pump is being used to feed fluid to a piston pump, and the intake valve of the piston pump does not close, causing fluid to back up in the outlet line.

- Use electrically conductive fluid hoses (P). The pump fluid outlet (N) is 3/8 npt(f). Screw the fluid fitting into the pump outlet snugly.
- Install a fluid regulator (H) at the pump fluid outlet to control fluid pressure, if desired. See **Air Line**, step 1a, for another method of controlling pressure.
- Install a fluid drain valve (J) near the fluid outlet. See the **WARNING** at left.

Flush the Pump Before First Use

The pump was tested in water. If the water could contaminate the fluid you are pumping, flush the pump thoroughly with a compatible solvent. Follow the steps under **Starting and Adjusting the Pump** on page 11.

Operation

Pressure Relief Procedure







WARNING

The system remains pressurized until pressure is manually relieved. To reduce the risk of serious injury from pressurized fluid, accidental spray from the gun, or splashing of any fluid, follow this procedure whenever you

- Stop spraying
- Are instructed to relieve pressure
- Check or service any system equipment
- Install, clean, or change spray nozzles

1. Shut off the bleed-type air valve (B).
2. *In a spray system*, hold the gun (S) firmly against a grounded metal pail and trigger the gun to relieve the fluid pressure.
3. Place the drain tube (K) in a waste pail. Open the drain/circulation valve (J) to relieve any fluid pressure trapped in the system.

Starting and Adjusting the Pump

1.   Read **Toxic Fluid Hazard** on page 5.
2.  If lifting the pump, follow the **Pressure Relief Procedure** above.
3.    Be sure the pump is properly grounded. Read **Fire and Explosion Hazard** on page 4.

4. Check all fittings to be sure they are tight. Use a compatible liquid thread sealant on all male threads. Tighten the fluid inlet and outlet fittings snugly. Do not overtighten the fittings.
5. Place the suction tube (L, if used) in the fluid to be pumped.
6. Place the fluid hose (P) in a container.
7. Close the drain/circulation valve (J).
8. Close the pump air regulator (F). Open all bleed-type master air valves (B, E).
9. If the fluid hose has a dispensing device, hold it open while continuing with the following step. Slowly open the air regulator (F) until the pump starts to cycle. Allow the pump to cycle slowly until all air is pushed out of the lines and the pump is primed.

If you are flushing, run the pump long enough to thoroughly clean the pump and hoses. Close the air regulator. Remove the suction tube from the solvent and place it in the fluid to be pumped.

Pump Shutdown

WARNING

To reduce the risk of serious injury whenever you are instructed to relieve pressure, always follow the **Pressure Relief Procedure** at left.

At the end of the work shift, flush the pump and relieve pressure.

Maintenance

Tightening Threaded Connections

Before each use, check all hoses for wear or damage. Replace as necessary. Check that all threaded connections are tight and leak-free.

Cleaning

Clean the outside of the equipment daily, using a soft cloth and compatible solvent.

Clean the suction tube (L) and inlet strainer daily, using a compatible solvent.

Clean the air filter (D) in your main air line at least once a week.

Storage

Before storing the pump, always flush it and relieve pressure.

Preventive Maintenance Schedule

Establish a preventive maintenance schedule, based on the pump's service history. This is especially important for prevention of spills or leakage due to diaphragm failure.

Troubleshooting

WARNING

To reduce the risk of serious injury whenever you are instructed to relieve pressure, always follow the **Pressure Relief Procedure** on page 11.

1. **Relieve the pressure** before checking or servicing the equipment.
2. Check all possible problems and causes before disassembling the pump.

PROBLEM	CAUSE	SOLUTION
Pump will not run.	Closed air line valve.	Open valve.
	Inadequate air supply, or clogged/restricted air line.	Increase air supply. Do not exceed maximum air inlet pressure.
		Open or clear air line.
		Clean air filter.
	Clogged pump, fluid line, or spray gun.	Clear, service. Flush regularly. Do not allow fluid to set up in the pump and lines.
	Stuck or damaged pump air valve.	Disassemble and clean air valve. Replace worn parts. See page 18. Use filtered air.
	Ruptured diaphragm.	Replace diaphragms. See page 17.
Air valve plate installed incorrectly.	Align plate with center housing. See page 19.	

Troubleshooting

PROBLEM	CAUSE	SOLUTION
Pump runs sluggishly.	Worn or damaged carriage o-rings.	Service air valve. See page 18.
Pump runs erratically.	Clogged suction line or inlet strainer.	Clear.
	Sticking or leaking ball check valves.	Disassemble and clean ball checks. Replace worn parts. See page 16.
Pump runs too fast.	Exhausted fluid supply.	Refill fluid supply and prime pump.
Pump cycles at stall or fails to hold pressure at stall.	Worn ball check valves.	Disassemble and clean ball checks. Replace worn parts. See page 16.
Audible air leak.	Worn air valve cup or plate.	Service air valve. See page 18.
Air exhausting from the mounting holes.	Fluid covers are installed incorrectly.	Align mounting holes in fluid covers with holes in center housing. See page 14.
Fluid in the exhaust air.	Ruptured diaphragm.	Replace diaphragms. See page 17.
Air bubbles in fluid.	Loose suction line.	Tighten. Use a compatible liquid thread sealant on connections.
	Ruptured diaphragm.	Replace diaphragms. See page 17.
Poor finish or irregular spray pattern.	Incorrect fluid or air pressure at gun.	See gun manual; read fluid manufacturer's recommendations. Use fluid regulator.
	Fluid is too thin or too thick.	Adjust fluid viscosity; read fluid manufacturer's recommendations.
	Dirty, worn, or damaged spray gun.	Service gun.
	Fluid is settling out.	Use agitator. Order Part No. 245081 Agitator Kit.

Service

Remove the Fluid and Side Covers

Tools Required

- Torque wrench
- 2.5 mm allen wrench
- 6 mm allen wrench
- Adjustable wrench

Disassembly

WARNING

To reduce the risk of serious injury whenever you are instructed to relieve pressure, always follow the **Pressure Relief Procedure** on page 11.

1. **Relieve the pressure.**
2. Disconnect the hoses and ground wire.

3. Remove the pump from its mounting.

CAUTION

Be careful that the ball checks do not fall out when you remove the fluid covers (32).

4. Remove the six screws (38) and top cover (32) from the center housing (1). Remove the ball check seals (24). Remove the bottom cover and seals.

NOTE: Always replace the ball check seals (24) whenever the fluid covers (32) are removed. These seals are included in the four repair kits.

NOTE: Perform step 5 only if you are servicing the air valve or the diaphragm shaft.

5. Remove the two screws (39) and take off the side cover (31) and felt dampener (29).

Service

Remove the Fluid and Side Covers (continued)

Reassembly

1. Clean all parts and inspect for wear or damage. Replace parts as needed.
2. If necessary, reinstall the felt dampener (29) and side cover (31). Torque the screws (39) to 28 in-lb (3.1 N•m).
3. Replace the ball check seals (24).
4. Place the fluid covers (32) on the housing (1). Align the mounting holes (H) in the fluid covers with the holes in the housing. Install the screws (38) loosely, then torque oppositely and evenly to 70 in-lb (8 N•m).
5. Reinstall the pump on its mounting.
6. Reconnect the ground wire and hoses.

- | | | | |
|---|--------------------|---|---|
| 1 | Align | 3 | 70 in-lb (8 N•m) |
| 2 | 28 in-lb (3.1 N•m) | 4 | Replace seals whenever cover (32) is removed. |

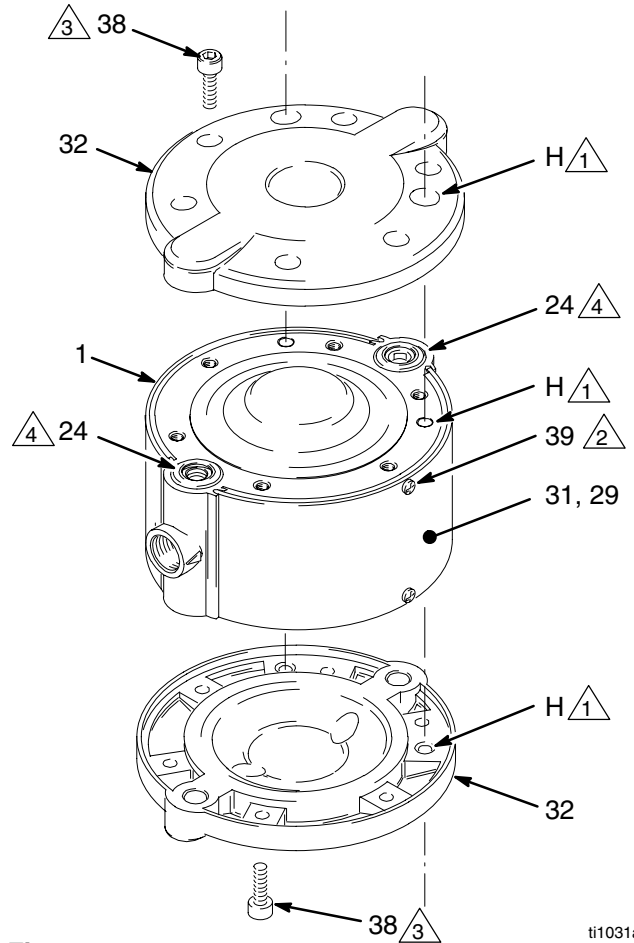

ti1031a

Service

Ball Check Repair

Tools Required

- O-ring pick

Disassembly

NOTE: Ball Check Repair Kit 245067 is available. Parts included in the kit are marked with a double dagger, for example (21‡). Use all the parts in the kit for the best results.

1. Remove the fluid covers. See page 14.
2. Remove the inlet and outlet ball checks. Note that the orientation of the inlet check parts is different from the outlet check parts. See Fig. 4.

NOTE: If the inlet seats (26) are difficult to remove, drive them out from the opposite side using a brass rod and hammer.

3. Clean all parts and inspect for wear or damage. Replace parts as needed.

Reassembly

1. Reinstall the inlet and outlet ball checks on one side of the pump. The inlet and outlet checks are assembled differently. Install the parts exactly as shown in Fig. 4.
2. Install one cover (32) loosely, to prevent the ball checks from falling out. See page 14.
3. Turn the pump over and install the ball checks on the opposite side, exactly as shown.
4. Reinstall the fluid covers. See page 14.

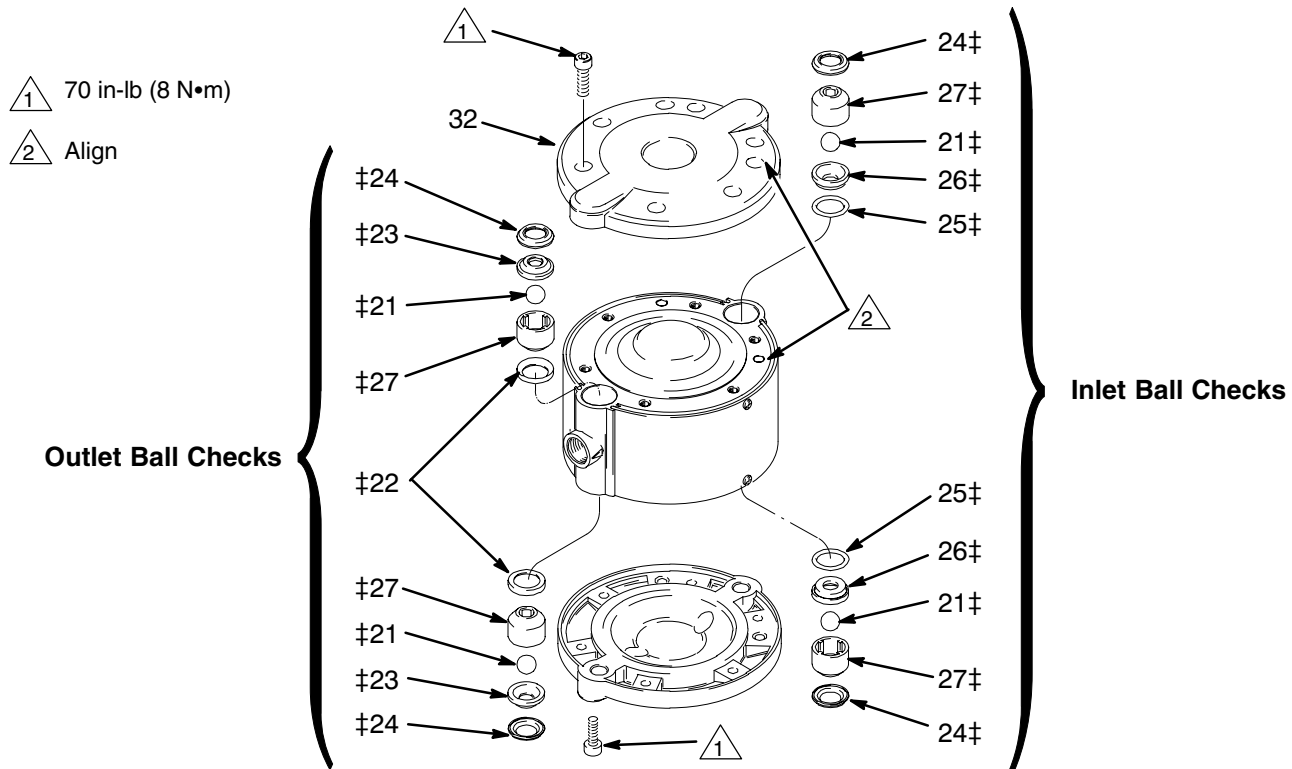

ti1032a

Service

Diaphragm Repair

Tools Required

- M8 bolt
- M8 hexnut
- Adjustable wrench, or vise

NOTE: Diaphragm Repair Kit 245065 is available. Parts included in the kit are marked with an asterisk, for example (6*). Always replace both diaphragms for the best results.

1. Remove the fluid covers. See page 14.

WARNING

Wear gloves when removing the diaphragms to reduce the risk of cuts.

2. Unscrew one diaphragm (6) from the shaft (5) by hand. See Fig. 5.

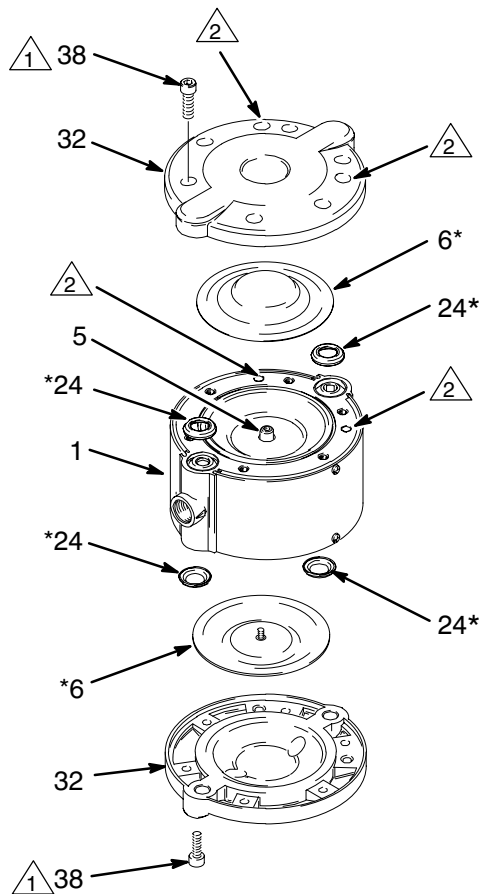

3. Thread an M8 hexnut (A) onto an M8 bolt. Screw the bolt into the shaft (5) until it bottoms out. Thread the nut down to the shaft to lock it.
4. Hold the nut with a wrench or vise to keep the shaft from turning. Unscrew the other diaphragm (6) by hand.

NOTE: If you cannot remove the second diaphragm, refer to **Shaft Repair Disassembly** on page 20.

Reassembly

1. Screw the new diaphragms (6*) into the shaft (5) handtight.
2. Replace the ball check seals (24*) with the new seals in the kit.
3. Reinstall the fluid covers. See page 14.

 1 70 in-lb (8 N•m)

 2 Align

 3 Use M8 bolt and nut to keep shaft from turning.

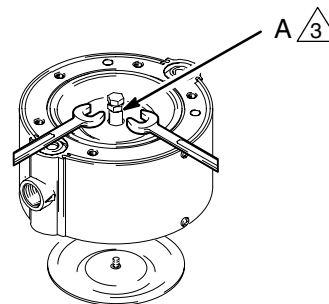

Fig. 5

ti1033a

Service

Air Valve Repair

Tools Required

- 3 mm allen wrench
- Needlenose pliers
- Retaining ring removal tool
- O-ring pick

Disassembly

NOTE: Air Valve Repair Kit 245066 is available. Parts included in the kit are marked with a dagger, for example (8†). Use all the parts in the kit for the best results.

1. Remove the side cover (31) and felt dampener (29).
2. Remove the four screws (36), air valve cover (17), and gasket (16). See Fig. 7.
3. See Fig. 6. Note the orientation of the air valve plate (13). Pull the plate out of the center housing (1). Remove the three o-rings (14, 15) from the plate. See Fig. 7.
4. Remove the air valve cup (12) from the center housing (1).
5. Remove the retaining ring (11) and plug (9), and slide the carriage (7) from the center housing (1). Remove the o-rings (8, 10) from the carriage and the plug.
6. Clean all parts and inspect for wear or damage. Replace parts as needed.

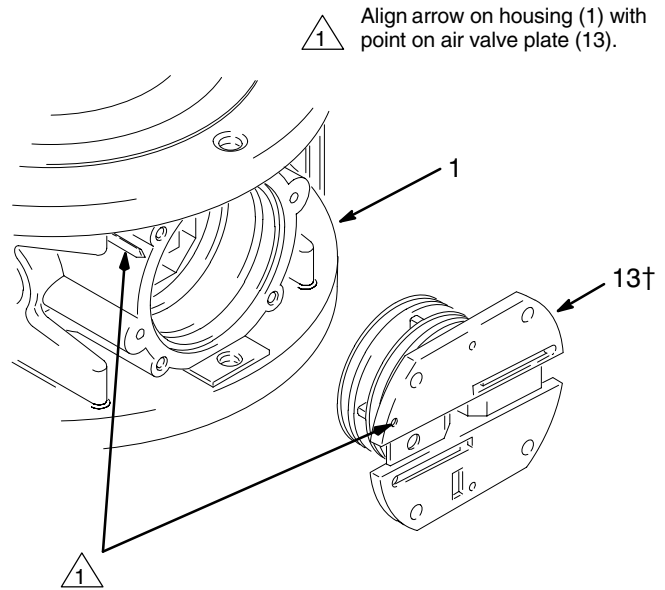

ti1039a

Fig. 6

Service

Air Valve Repair (continued)

Reassembly

1. Lubricate the o-rings (8†) and install them on the carriage (7). Slide the carriage into the center housing (1) so the notch faces out, as shown in Fig. 7.
2. Lubricate the o-ring (10†) and install it on the plug (9). Insert the plug in the hole to secure the carriage (7). Install the retaining ring (11) to hold these parts in place.
3. Install the air valve cup (12†) in the notch of the carriage (7) so the open side faces out.
4. Lubricate the large o-ring (15†) and the two small o-rings (14†) and install them on the air valve plate (13†). Align the point on the plate with the arrow on the center housing (1) as shown in Fig. 6. Install the plate in the housing.
5. Install the gasket (16†). Note the orientation.
6. Reinstall the air valve cover (17) and screws (36). Torque the screws to 28 in-lb (3.1 N•m).
7. Replace the ball check seals (24†) with the new seals in the kit.
8. Reinstall the felt dampener (29) and side cover (31). See page 14.

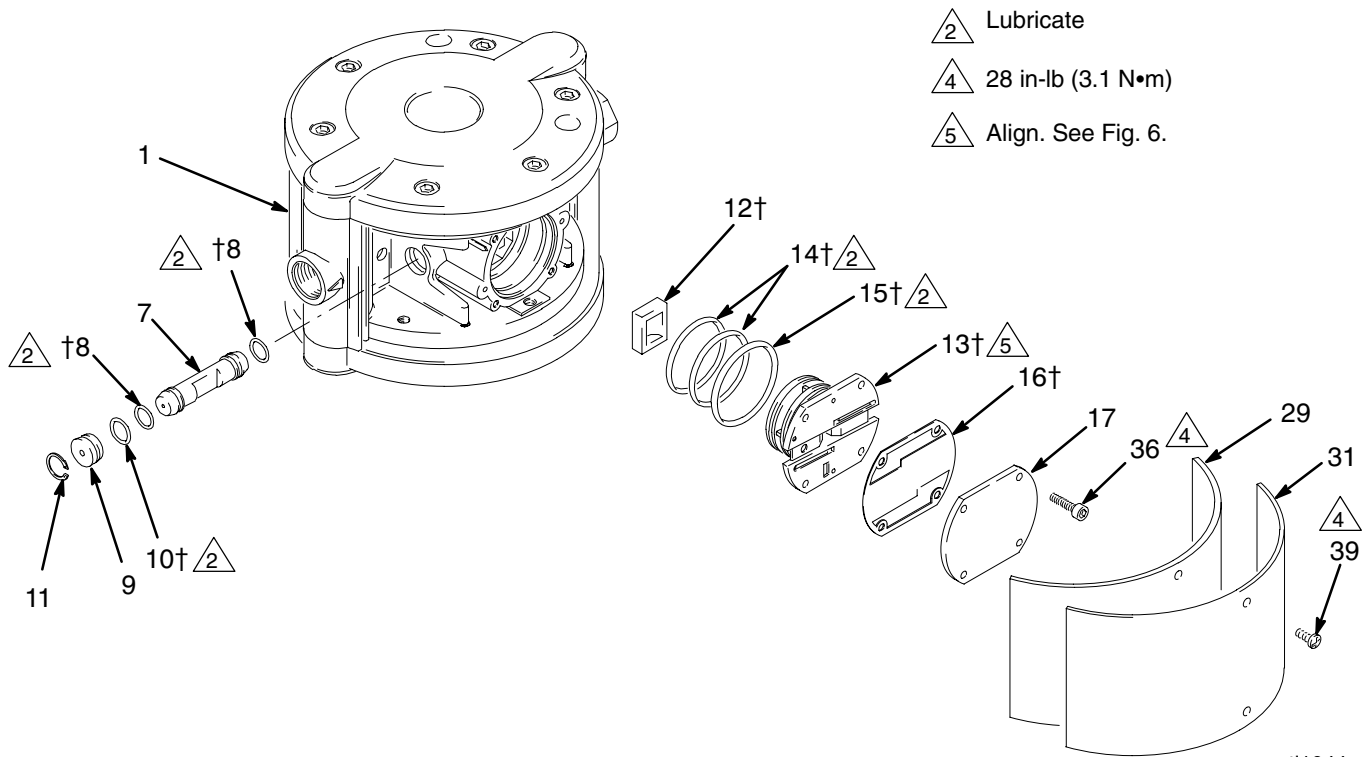

Fig. 7

ti1044a

Service

Shaft Repair

Tools Required

- Needlenose pliers
- O-ring pick
- Retaining ring removal tool
- Vise with soft jaws

Disassembly

NOTE: Shaft Repair Kit 245068 is available. Parts included in the kit are marked with a star, for example (2☆). Use all the parts in the kit for the best results.

1. Remove the fluid covers. See page 14. Remove the side cover (31) and felt dampener (29).
2. Disassemble the air valve. See page 18.
3. Remove the diaphragms (6). See page 17.
4. Remove the retaining rings (4) from the shaft (5). See Fig. 8.
5. Slide the shaft (5) out of the center housing (1). Remove the valve carriage (3) from the housing.
6. Remove the o-rings (2) from the shaft (5).

CAUTION

Do not grip the shaft with tools that can scratch or damage the shaft, such as wrenches or pliers.

7. *If you could not remove one diaphragm from the shaft*, place the shaft in a vise with soft jaws. Unscrew the remaining diaphragm (6) from the shaft (5) by hand.
8. Clean all parts and inspect for wear or damage. Replace parts as needed.

Reassembly

1. Screw one diaphragm (6) into the shaft (5☆) handtight.
2. Grease the o-rings (2☆) and install them on the shaft (5☆).
3. Place the valve carriage (3) in the center housing (1). Grease the shaft (5☆) and slide it through the center housing and valve carriage.
4. Install the retaining rings (4) on the shaft (5☆).
5. Screw the second diaphragm (6) into the shaft (5☆) handtight.
6. Reassemble the air valve and carriage (see page 18), using the new o-rings (8☆, 10☆, 14☆, 15☆) and gasket (16☆) included in the shaft repair kit.
7. Replace the ball check seals (24☆) with the new seals in the kit.
8. Reinstall the fluid covers. See page 14.

Service

Shaft Repair (continued)

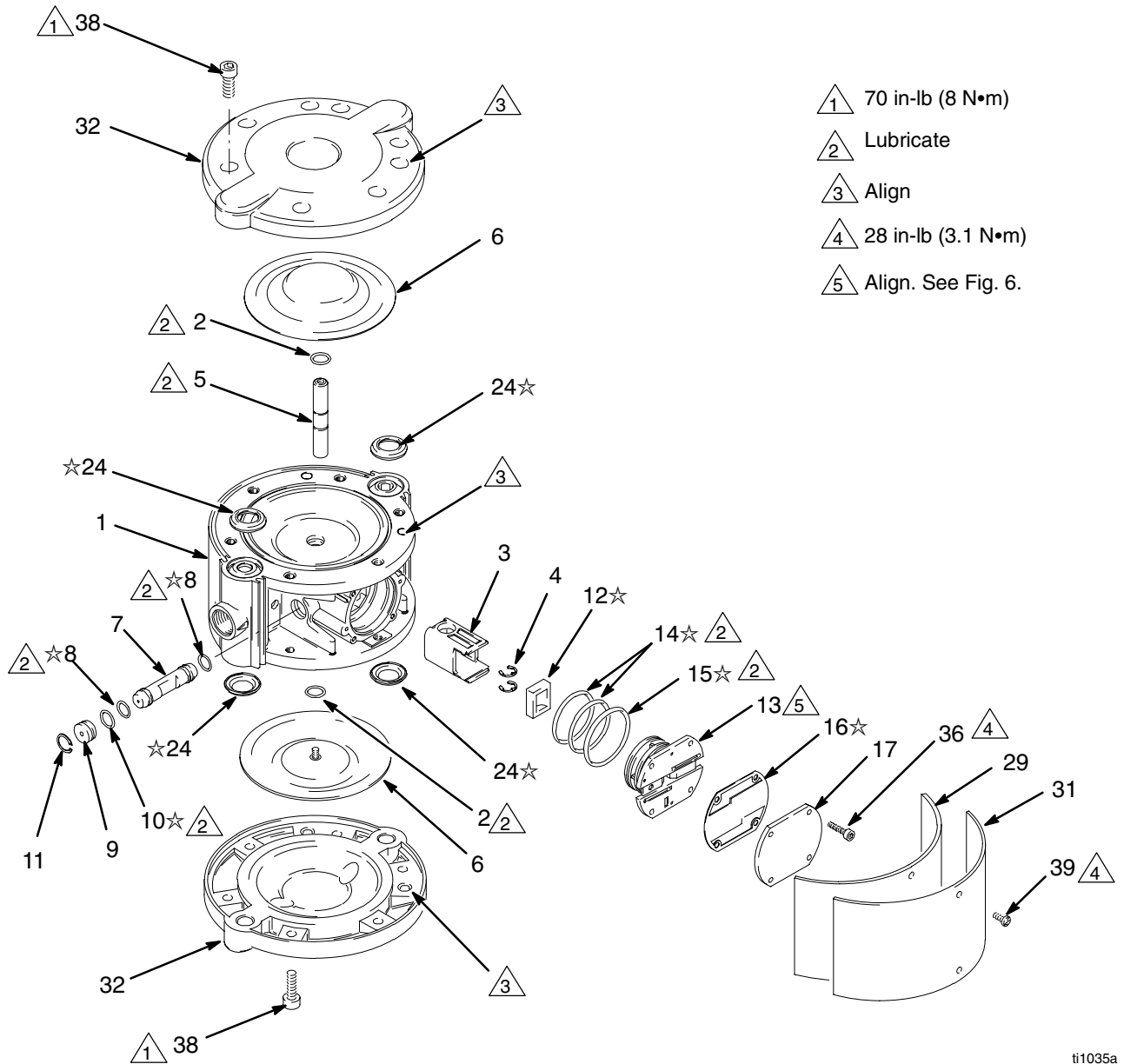

Fig. 8

ti1035a

Parts

Part No. 233500 Aluminum Pump, Series A

Part No. 233501 Stainless Steel Pump, Series A

Ref. No.	Part No.	Description	Qty.	Ref. No.	Part No.	Description	Qty.
1	197643	HOUSING, center; for Part No. 233500; aluminum	1	29	197671	DAMPENER, felt, side	1
	197679	HOUSING, center; for Part No. 233501; stainless steel	1	30	197672	COVER, air inlet side	1
2☆	197644	O-RING, shaft, diaphragm	2	31	197673	COVER, side	1
3	197645	CARRIAGE, valve	1	32	197674	COVER, housing; for Part No. 233500; aluminum	2
4	197646	RING, retaining, shaft	2		197680	COVER, housing; for Part No. 233501; stainless steel	2
5☆	197647	SHAFT, diaphragm	1	33	197675	FITTING, air inlet	1
6*	197648	DIAPHRAGM; PTFE®	2	34	197676	GASKET	1
7	197649	CARRIAGE	1	35	197677	CLAMP, grounding	1
8†☆	197650	O-RING, carriage	2	36	116474	SCREW, cap, socket-hd; M4 x 20	4
9	197651	PLUG, carriage	1		116475	SCREW, cap, socket-hd; M4 x 12	2
10†☆	197652	O-RING, plug	1	37	116476	SCREW, cap, socket-hd; M8 x 20	12
11	197653	RING, retaining, carriage	1	38	116595	SCREW, button-hd; M4 x 12	2
12†	197654	CUP, valve, air	1	40▲	188621	LABEL, warning	1
13†	197655	PLATE, valve, air	1				
14†☆	197656	O-RING, valve, air	2				
15†☆	197657	O-RING, valve, air	1				
16†☆	197658	GASKET, valve, air	1				
17	197659	COVER, valve, air	1				
18	197660	VALVE, safety, air	1				
19	197661	PLATE, dampener; neoprene	1				
20	197662	DAMPENER; steel	1				
21‡	197663	BALL; acetal	4				
22‡	197664	SEAL, valve, outlet; acetal	2				
23‡	197665	SEAT, valve, outlet; stainless steel	2				
24*†‡☆	197666	SEAL, ball check; nylon	4				
25‡	197667	O-RING, valve, inlet; Viton®	2				
26‡	197668	SEAT, valve, inlet; stainless steel	2				
27‡	197669	GUIDE, ball; acetal	4				
28	197670	DAMPENER, felt, air inlet side	2				

* These parts are included in Diaphragm Repair Kit 245065, which may be purchased separately.

† These parts are included in Air Valve Repair Kit 245066, which may be purchased separately.

‡ These parts are included in Ball Check Repair Kit 245067, which may be purchased separately.

☆ These parts are included in Shaft Repair Kit 245068, which may be purchased separately.

▲ Replacement Danger and Warning labels, tags and cards are available at no cost.

Parts

Part No. 233500 Aluminum Pump, Series A

Part No. 233501 Stainless Steel Pump, Series A (Shown)

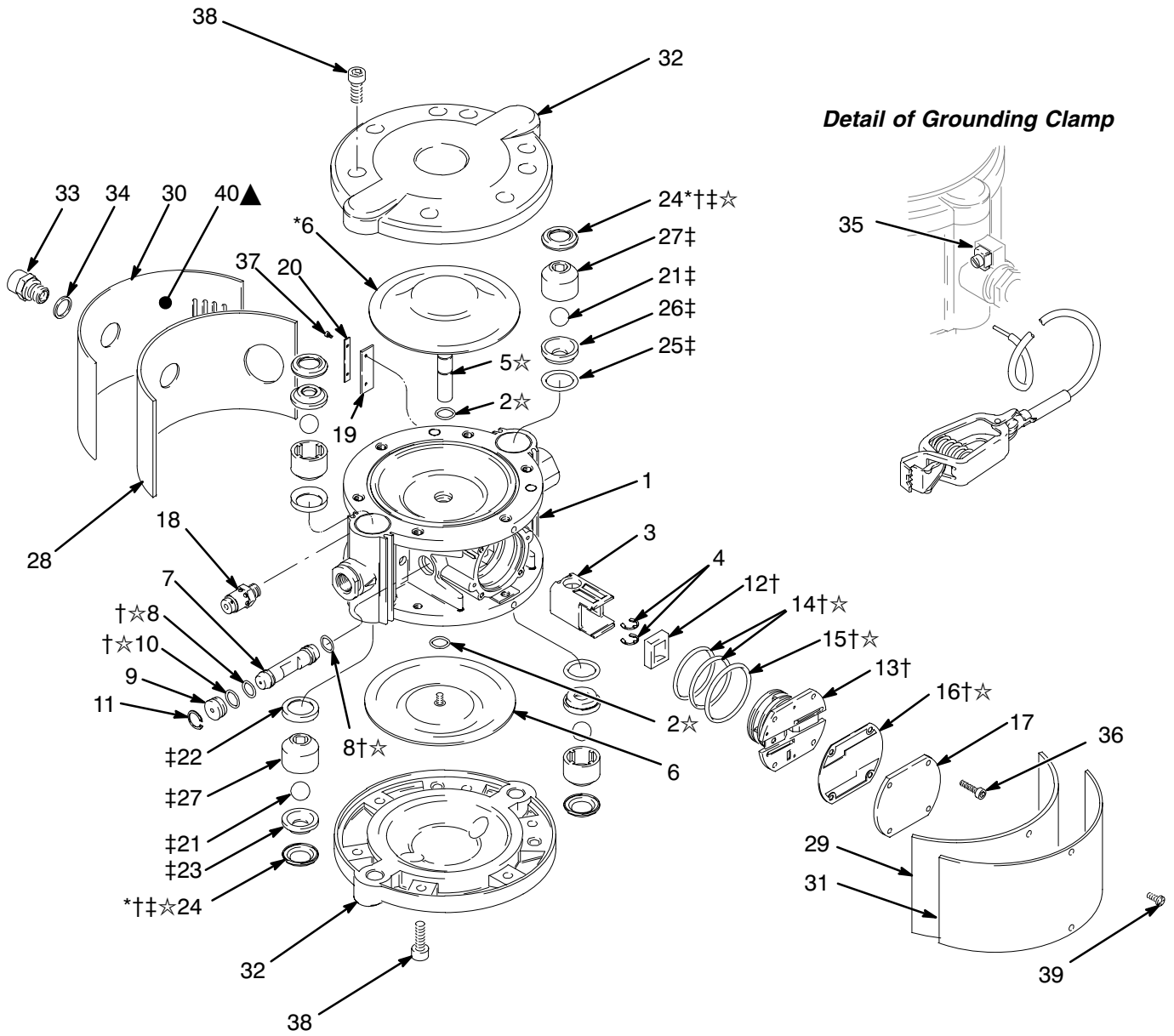

ti1036a

Technical Data

Category	Data
Maximum fluid working pressure	115 psi (0.8 MPa, 8.0 bar)
Air pressure operating range	12 to 115 psi (.08 to 0.8 MPa, 0.8 to 8.0 bar)
Ratio	1:1
Maximum free flow delivery	8.5 gal./min (32 l/min)
Operating temperature range	50 to 176° C (10 to 80° C)
Maximum suction lift	16 ft (4.8 m) dry; 22 ft (6.7 m) wet
Weight	Part No. 233500: 9 lb (4 kg) Part No. 233501: 14 lb (6.4 kg)
Wetted parts	Part No. 233500: Aluminum, Stainless Steel, Acetal, Nylon, PTFE® Part No. 233501: Stainless Steel, Acetal, Nylon, PTFE®

PTFE® and Viton®

Sound Pressure Levels in dB(A)* (measured at 1 m from unit)

Input Air Pressures	Sound Pressure
40 psi (0.28 MPa, 2.8 bar)	69.1
60 psi (0.42 MPa, 4.2 bar)	72.1

Sound Power Levels in dB(A)* (tested in accordance with ISO 3744)

Input Air Pressures	Sound Power
40 psi (0.28 MPa, 2.8 bar)	80.8
60 psi (0.42 MPa, 4.2 bar)	83.7

Performance Chart

To find Fluid Outlet Pressure (psi/MPa/bar) at a specific fluid flow (lpm/gpm) and operating air pressure (psi/MPa/bar):

1. Locate desired flow along bottom of chart.
2. Follow vertical line up to intersection with selected fluid outlet pressure curve (black). Follow left to scale to read fluid outlet pressure.

To find Pump Air Consumption (l/min or scfm) at a specific fluid flow (lpm/gpm) and air pressure (psi/MPa/bar):

1. Locate desired flow along bottom of chart.
2. Read vertical line up to intersection with selected air consumption curve (dashes). Follow left to scale to read air consumption.

- A 115 psi (0.8 MPa, 8 bar) air pressure
- B 90 psi (0.6 MPa, 6 bar) air pressure
- C 60 psi (0.4 MPa, 4 bar) air pressure
- D 30 psi (0.2 MPa, 2 bar) air pressure

Test Fluid: No. 10 Weight Oil

Fluid Outlet Pressure

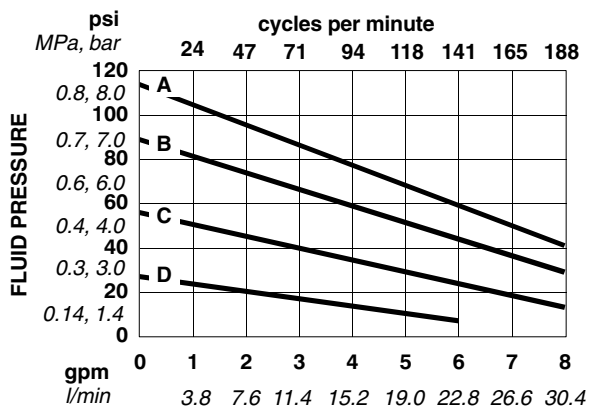

Air Consumption

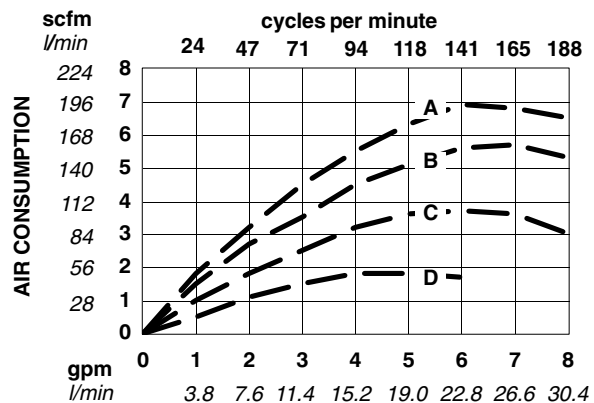

Dimensions

BOTTOM VIEW

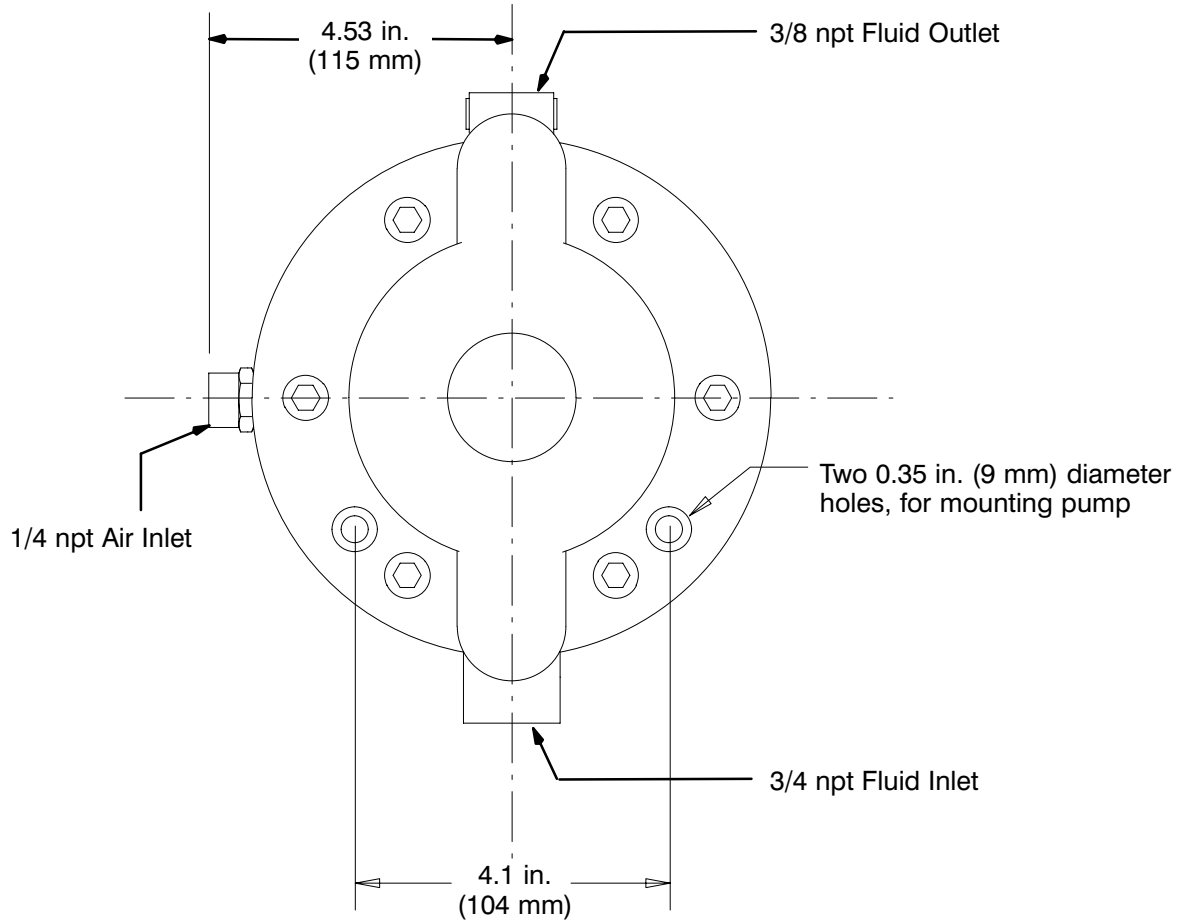

SIDE VIEW

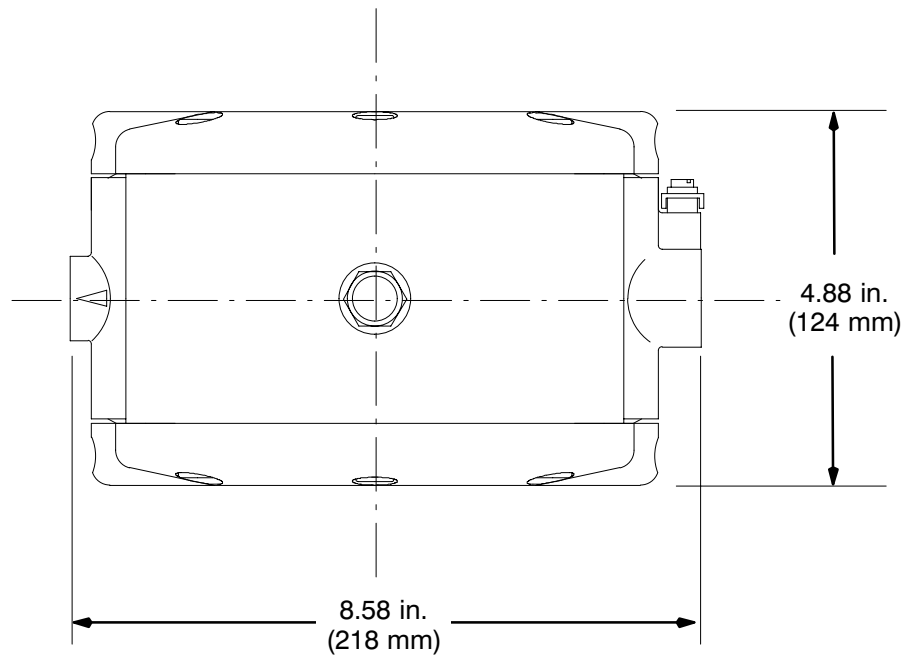

ti1037a

Graco Standard Warranty

Graco warrants all equipment manufactured by Graco and bearing its name to be free from defects in material and workmanship on the date of sale by an authorized Graco distributor to the original purchaser for use. With the exception of any special, extended, or limited warranty published by Graco, Graco will, for a period of twelve months from the date of sale, repair or replace any part of the equipment determined by Graco to be defective. This warranty applies only when the equipment is installed, operated and maintained in accordance with Graco's written recommendations.

This warranty does not cover, and Graco shall not be liable for general wear and tear, or any malfunction, damage or wear caused by faulty installation, misapplication, abrasion, corrosion, inadequate or improper maintenance, negligence, accident, tampering, or substitution of non-Graco component parts. Nor shall Graco be liable for malfunction, damage or wear caused by the incompatibility of Graco equipment with structures, accessories, equipment or materials not supplied by Graco, or the improper design, manufacture, installation, operation or maintenance of structures, accessories, equipment or materials not supplied by Graco.

This warranty is conditioned upon the prepaid return of the equipment claimed to be defective to an authorized Graco distributor for verification of the claimed defect. If the claimed defect is verified, Graco will repair or replace free of charge any defective parts. The equipment will be returned to the original purchaser transportation prepaid. If inspection of the equipment does not disclose any defect in material or workmanship, repairs will be made at a reasonable charge, which charges may include the costs of parts, labor, and transportation.

THIS WARRANTY IS EXCLUSIVE, AND IS IN LIEU OF ANY OTHER WARRANTIES, EXPRESS OR IMPLIED, INCLUDING BUT NOT LIMITED TO WARRANTY OF MERCHANTABILITY OR WARRANTY OF FITNESS FOR A PARTICULAR PURPOSE.

Graco's sole obligation and buyer's sole remedy for any breach of warranty shall be as set forth above. The buyer agrees that no other remedy (including, but not limited to, incidental or consequential damages for lost profits, lost sales, injury to person or property, or any other incidental or consequential loss) shall be available. Any action for breach of warranty must be brought within two (2) years of the date of sale.

Graco makes no warranty, and disclaims all implied warranties of merchantability and fitness for a particular purpose in connection with accessories, equipment, materials or components sold but not manufactured by Graco. These items sold, but not manufactured by Graco (such as electric motors, switches, hose, etc.), are subject to the warranty, if any, of their manufacturer. Graco will provide purchaser with reasonable assistance in making any claim for breach of these warranties.

In no event will Graco be liable for indirect, incidental, special or consequential damages resulting from Graco supplying equipment hereunder, or the furnishing, performance, or use of any products or other goods sold hereto, whether due to a breach of contract, breach of warranty, the negligence of Graco, or otherwise.

FOR GRACO CANADA CUSTOMERS

The parties acknowledge that they have required that the present document, as well as all documents, notices and legal proceedings entered into, given or instituted pursuant hereto or relating directly or indirectly hereto, be drawn up in English. Les parties reconnaissent avoir convenu que la rédaction du présente document sera en Anglais, ainsi que tous documents, avis et procédures judiciaires exécutés, donnés ou intentés à la suite de ou en rapport, directement ou indirectement, avec les procédures concernées.

Graco Phone Numbers

TO PLACE AN ORDER, contact your Graco distributor, or call one of these numbers to identify the distributor closest to you:

1-800-367-4023 Toll Free
1-612-623-6921 In Minnesota
1-612-378-3505 Fax

*All written and visual data contained in this document reflects the latest product information available at the time of publication.
Graco reserves the right to make changes at any time without notice.*

Sales Offices: Minneapolis, Detroit
International Offices: Belgium, Korea, Hong Kong, Japan

GRACO INC. P.O. BOX 1441 MINNEAPOLIS, MN 55440-1441

www.graco.com

PRINTED IN USA 309303 February 2001