

Repair



Interior Texture Sprayers

Zip-Text™ 750 and Zip-Text™ 1000

309800K

For Water-Based Materials Only

Models:

246318 Zip-Text 750, 6 Gallon

55 psi (3.79 bar) Maximum Fluid Working Pressure

246319 Zip-Text 1000, 8 Gallon

60 psi (4.14 bar) Maximum Fluid Working Pressure



Read warnings and instructions.

Related Manuals





309798



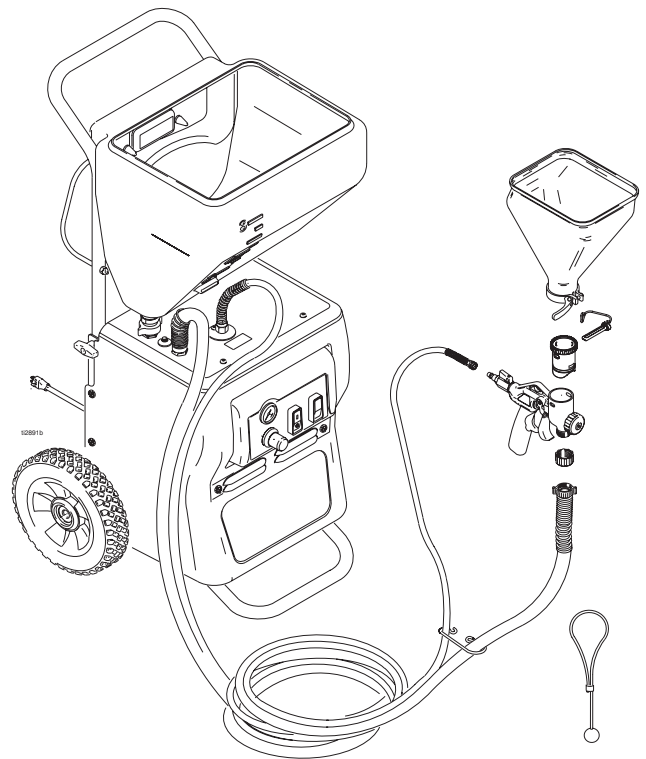



309799

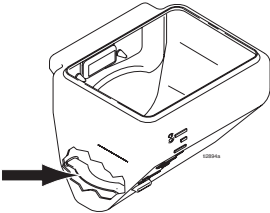

Model 246319 Shown

WARNINGS	
	<p>Fire and Explosion Hazard Improper grounding, poor ventilation, open flames or sparks can cause a hazardous condition and result in fire or explosion and serious injury.</p> <ul style="list-style-type: none"> • The system is for use with water-based materials only. Only use fluids compatible with the equipment. Refer to Technical Data of all equipment manuals. Read fluid and solvent manufacturers warnings. • Ground the equipment. See Grounding and Electrical Requirements, page 5. • If there is any static sparking or you feel an electric shock while using this equipment, stop spraying immediately. Do not use the equipment until you identify and correct the equipment until you identify and correct the problem. • Keep work area free of debris, including solvent, rags and gasoline. • Comply with all applicable state and national fire, electrical and safety regulations.
	<p>Equipment Misuse Hazard Equipment misuse can cause equipment to rupture, malfunction, or start unexpectedly and cause serious injury.</p> <ul style="list-style-type: none"> • Before operating this equipment, read all manuals, tags, and labels, including material labels and instructions. • Do not expose system to rain. Always store system indoors. • Do not alter or modify equipment. • Do not spray cementitious materials. • Do not exceed maximum working pressure of lowest rated component in your system. • Check equipment daily. Repair or replace worn or damaged parts immediately. • To reduce risk of serious injury, including electric shock and splashing fluid in eyes, follow Pressure Relief Procedure on page 5 before servicing the unit. • Do not use hoses to pull equipment. • Route hoses away from traffic areas, sharp edges, moving parts and hot surfaces. Do not expose hoses to temperatures above 130 F (55 C) or below -35 F (-37 C). • Air hoses at the compressor end, can get very hot! Allow sprayer to cool down 15 minutes before removing air hose. • Store hazardous fluid in an approved container. Dispose of hazardous fluid according to all local, state and national guidelines. • Never directly inhale compressed air. Compressed air may contain toxic vapors.

WARNINGS	
 	<p>Electric Shock Hazard To reduce the risk of electric shock:</p> <ul style="list-style-type: none"> • Be sure sprayer is adequately grounded through electrical outlet, page 5. • Use only 3-wire, extension cords. • Make sure ground prongs are intact on sprayer and extension cords. • Do not operate with cover removed. • Turn off sprayer. Follow Pressure Relief Procedure, page 5, and unplug unit, before removing any parts.
	<p>Pressurized Equipment Hazard Fluid from gun, leaks or ruptured components can splash in the eyes or on skin and cause serious injury.</p> <ul style="list-style-type: none"> • Follow Pressure Relief Procedure, page 5 when you stop spraying and before cleaning, checking or servicing. • Do not point spray gun at anyone; put hand, fingers or rag over nozzle, or stop or deflect leaks with your hand, body, glove, or rag. • Wear protective clothing, gloves, and eyewear. <div style="display: flex; align-items: flex-start;">  <ul style="list-style-type: none"> • Before adding material to hopper, install burp guard. When only a small amount of material remains in the hopper, the burp guard prevents material from shooting out when the unit is turned off. This material could splash in the operator's eyes or on skin, or into the air. </div>
	<p>Cleaning Solvent Hazard with Plastic Parts Use only compatible water-based solvents to clean plastic structural or pressure-containing parts. Many solvents can degrade plastic parts to the point where they could fail. Such failure could cause serious injury or property damage. See Technical Data on page 26 of this instruction manual and in all other equipment manuals. Read fluid and solvent manufacturer's warnings.</p>

	<p>CAUTION</p> <p>Water or material remaining in unit when temperatures are below freezing can damage motor and/or delay pump startup.</p> <p>To insure water and material are completely drained out of unit:</p> <ol style="list-style-type: none"> 1. Remove material line from sprayer. 2. Tip sprayer up as shown. <p>Before adding material or starting unit in cold weather, run warm water through pump.</p>
---	---

Component Identification

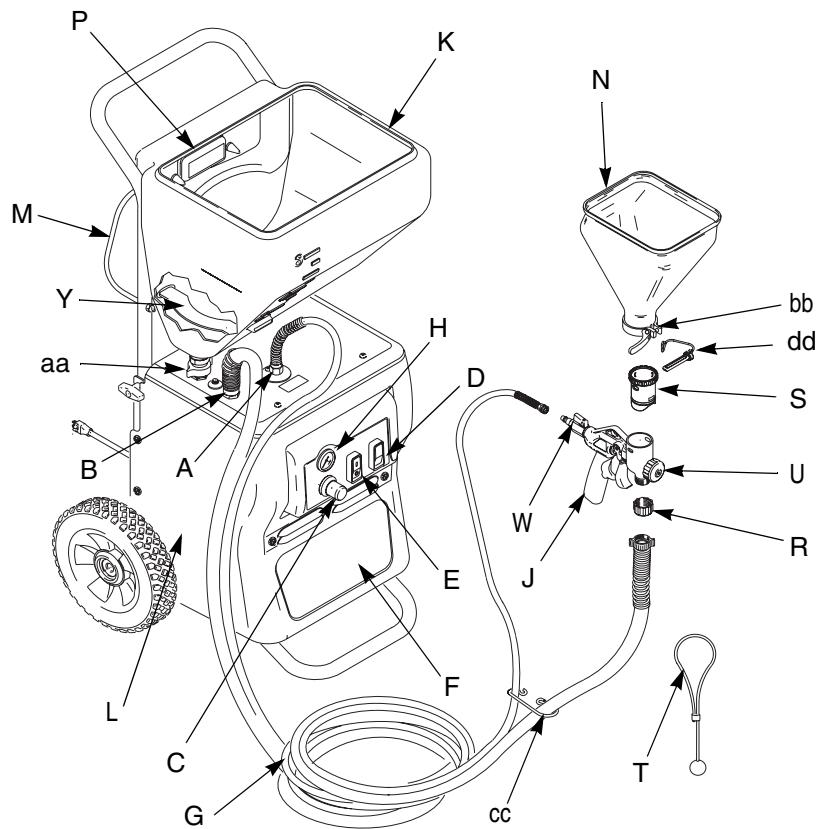

Item	Component	Item	Component
A	Air hose outlet	N	Touch-up hopper (3/4 gallon)
B	Material hose outlet	P	Nozzle storage
C	Material flow control (Zip-Tex 1000)	R	Hose plug
D	Hopper gun/spray gun selector switch	S	Gun plug
E	ON/OFF switch	T	Material thickness gauge
F	Air Compressor (inside)	U	Nozzle
G	Material/air hose	W	Gun air valve
H	Material flow indicator (Zip Tex 1000)	Y	Burp guard
J	Texture spray gun (manual 309798)	aa	Hopper fitting (fluid inlet)
K	Material Hopper - 6 gallon, Zip-Tex 750 Material Hopper - 8 gallon, Zip-Tex 1000I	bb	Hopper clamp
L	RotoFlex™ pump (inside)	cc	Hose clip
M	Hose rack/cord wrap	dd	Gun plug clip

Preparation

Pressure Relief Procedure



To reduce risk of injury, follow this procedure whenever you see this symbol throughout this manual, Also, perform this procedure whenever you:

- stop spraying.
- check or repair any part of this system.
- install or clean spray nozzle.



WARNING



page 2

1. Turn Power Switch OFF.

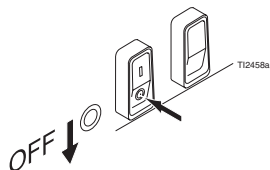

2. Trigger gun into material hopper.

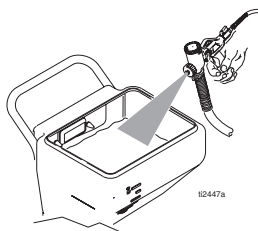

3. Open gun air valve.

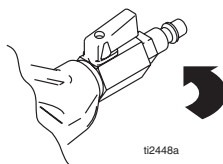

Grounding and Electrical Requirements

This sprayer must be grounded. Grounding reduces the risk of electrical shock by providing an escape wire for the electrical current. The sprayer cord includes a grounding wire with an appropriate grounding plug. The plug must be plugged into an outlet that is properly installed and grounded in accordance with all local codes and ordinances.

Check with a qualified electrician or serviceman if grounding instructions are not completely understood, or if in doubt as to whether the product is properly grounded. Do not modify plug provided; if it will not fit the outlet, have proper outlet installed by a qualified electrician.



WARNING



page 2

120V AC Systems

- This equipment requires a 120V AC, 60 Hz, 15A circuit with a grounding receptacle. Do not use an adapter with this product.

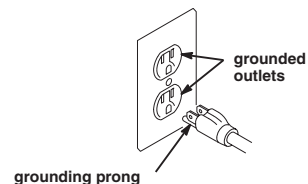

Extension Cords

- Use only an extension cord with an undamaged, 3-prong plug.
- For 25 to 50 ft (7.6 to 15.2 m) cords, use 3-wire, 14 AWG (1.5 mm²) minimum.
- For up to 100 ft. (30.48 m) cord, use 3-wire, 12 AWG (2.5 mm²) minimum.

Auxiliary Air Compressor

Do not use an auxiliary air compressor with this spray system.

Generator Requirements

3500 W (3.5 KW) minimum.

Hose Size and Length

The system comes with a hose set consisting of a 3/4 in. ID x 25 ft (25 mm x 7.6 m) material hose and a 3/8 in-ID air hose.

Do not use more than 25 ft. (7.6 m) of material hose.



WARNING



page 2

RotoFlex™ Pump

Disassembly

1. Relieve Pressure, page 5.
2. Unplug sprayer from outlet.
3. Remove shroud (6 bolts).

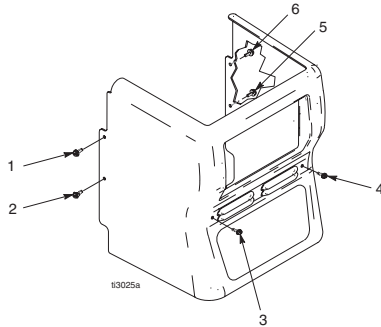

6. Loosen bolt (A) located between air and material hose outlets. Unscrew bolt to lower plate, leaving about 4-5 threads on bolt.

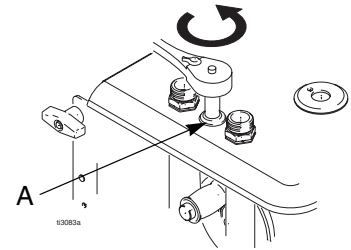

DO NOT REMOVE BOLT COMPLETELY.

4. Remove hopper by loosening bottom fitting and then lifting hopper straight up, off unit.

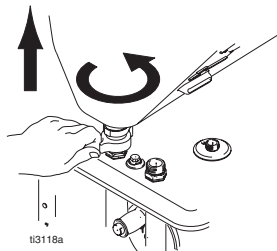

7. Slide a 2 x 4 under motor for support.

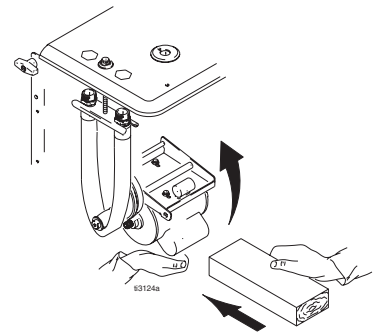

5. Remove material hose.

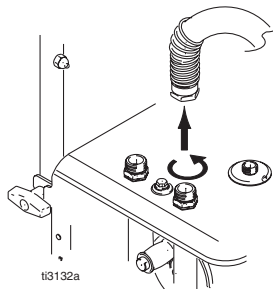

8. Rotate plate. Slide hose off by pushing outward on hose fitting.

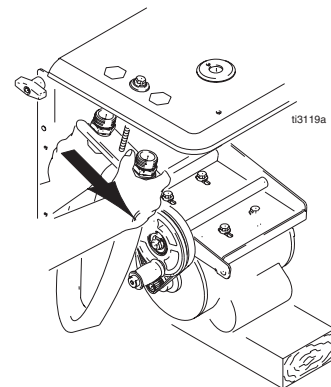

Reassembly

Reinstall RotoFlex Pump hose on plate.

1. Kink hose as shown, making sure dots located on hose fitting face each other.

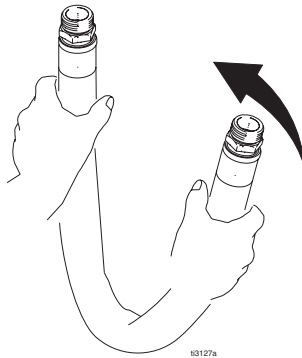

2. Slide hose onto plate as shown below, making sure plate slides into slot between hex fitting on end of hose.

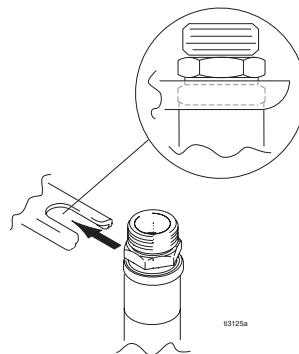

3. Align dots located on hose fitting, making sure they are facing each other at all times to ensure the hose does not twist during reinstallation.

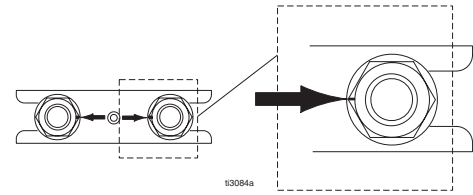

4. Reposition plate, aligning hex fittings with enclosure openings.
5. Remove 2 x 4 support under motor.
6. Tighten bolt. As bolt is tightened the plate will snug back into place.
7. Replace shroud (6 bolts).
8. Replace hopper.
9. Break in new pump by running dry or with warm water for 3-5 minutes.

Compressor Repair

Use Compressor Repair Kit, 234211.

Disassembly

1. Relieve Pressure, page 5.
2. Unplug sprayer.
3. Remove shroud (6 bolts)

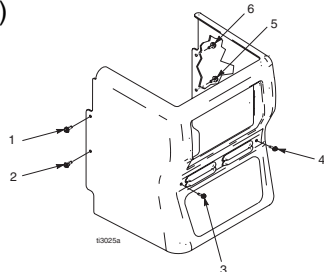

4. Remove green ground wire and black, and white wires to compressor.

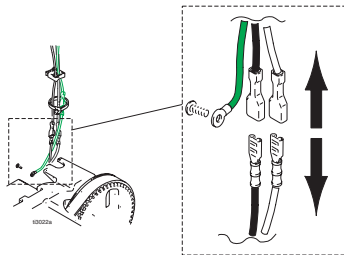

5. Loosen fittings (A and B) and remove air line.

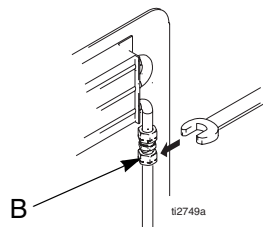
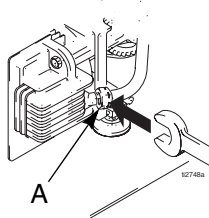

6. Using a socket wrench with extension, loosen bolts (3).

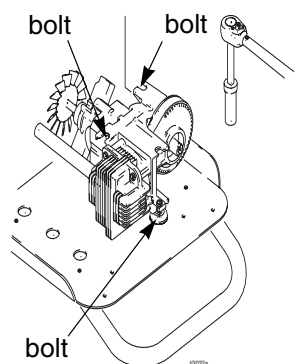

7. Tilt compressor forward and remove from housing.

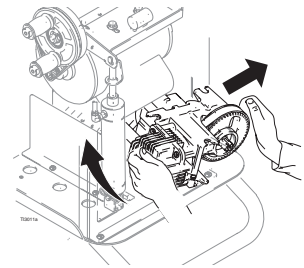

CAUTION

Fan blades are very delicate and can be damaged very easily. When removing or replacing compressor, do not bump or jar shroud or fan blades.

8. Thoroughly clean inside housing, removing dust and debris.

Reassembly

1. Carefully position compressor in housing.
2. Replace bolts using socket wrench to tighten. Torque to 85 in. lbs.

3. Reattach air lines to compressor. Finger tighten plus one full turn, fittings (A and B).

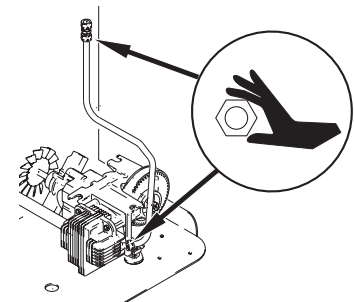

4. Reattach 3 wires to compressor matching green to green, black to black and white to white.

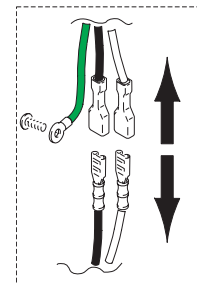

5. Replace shroud. Tighten bolts (6).

Roller Replacement

Use Roller Repair Kit 234214.

Disassembly

1. **Relieve Pressure**, page 5.
2. Unplug sprayer from outlet
3. Remove shroud (6 bolts).

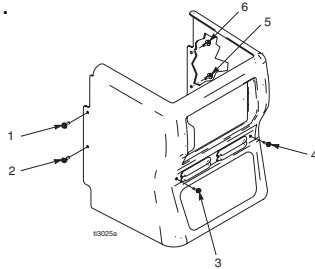

4. Remove RotoFlex Pump, page 6.
5. Using a crow bar as a wedge to keep rollers from moving, loosen shoulder bolt.

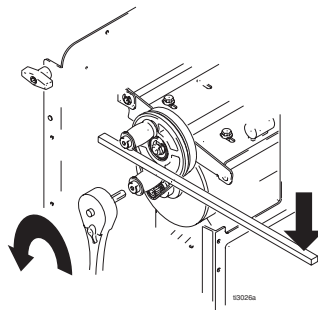

6. Remove rollers.

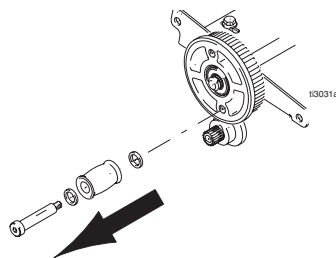

Reassembly

CAUTION

When installing bolt through roller, keep nylon washer on shoulder of bolt.

1. Replace rollers.

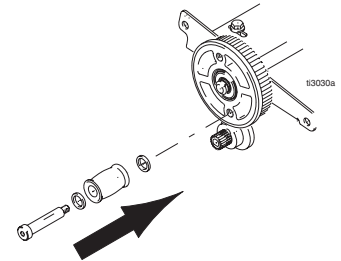

2. Using a crow bar as a wedge to keep rollers from moving, torque bolts to 40 ft. lbs.

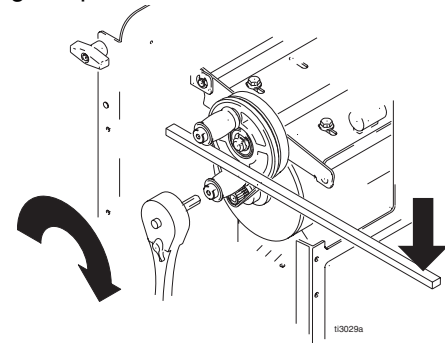

3. Reinstall RotoFlex Pump hose on plate, page 6.
4. Replace shroud. Tighten bolts (6).

Cylinder

Use Cylinder Repair Kit 246574, Zip-Tex 750.
Use Cylinder Repair Kit 246575, Zip-Tex 1000.

Disassembly

1. **Relieve Pressure**, page 5.
2. Unplug sprayer from outlet.
3. Remove shroud (6 bolts).

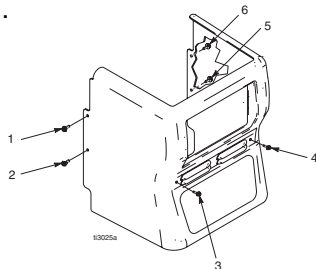

4. Disconnect air hose at quick disconnect fitting.

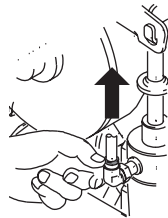

5. Remove clip.
6. Remove pin.

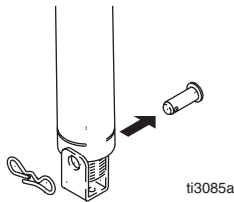

7. Pull swing arm out of opening.

Reassembly

1. Insert swing arm through hole.

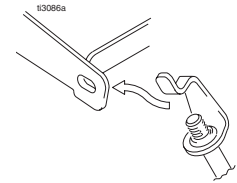

2. Align hole in bottom of cylinder with holes in bottom bracket.

3. Feed pin through opening.

4. Replace clip.

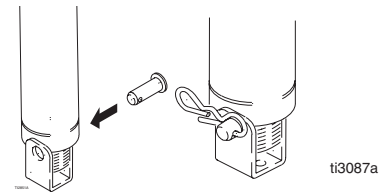

5. Reattach air hose to quick disconnect fitting.

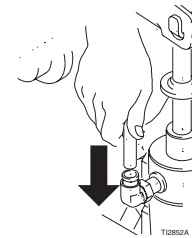

6. Replace shroud. Tighten bolts (6).

Capacitor Replacement

Use Capacitor Replacement Kit 246683.

⚠ WARNING

page 2

Disassembly

1. **Relieve Pressure**, page 5.
2. Unplug sprayer.
3. Remove shroud, (6 bolts).

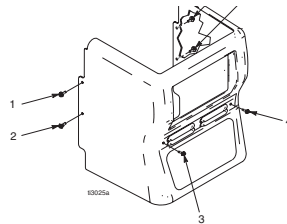

4. Capacitors can hold a charge. To prevent electric shock, use a flat bladed screw driver as a conductive device to short out the terminals. To do this, touch the blade of the flat screw driver between two terminal posts on the capacitor.

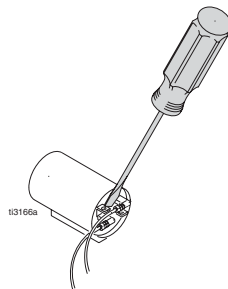

⚠ CAUTION

Do not touch metal part of screw driver when shorting out capacitor.

5. Cut strap.
6. Unplug capacitor and remove.

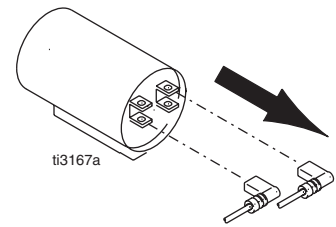

7. Clean surface to remove dirt and any remaining adhesive.

Reassembly

1. Remove backing from one side of two-sided tape provided in kit and apply to bottom of capacitor.
2. Plug in new capacitor.

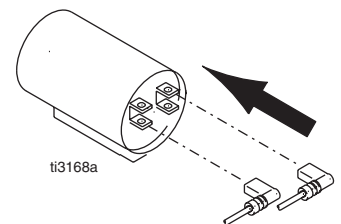

Wires are not polarized. It does not matter which wires are connected together between capacitor and motor.

3. Remove backing from bottom of two sided tape. Attach capacitor to plate, pressing taped side firmly into position. Secure using a wire tie.
4. Replace shroud. Tighten bolts (6).

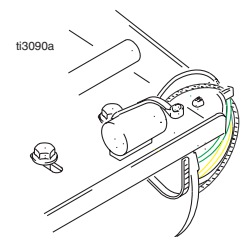

Motor Repair

Use Motor Repair Kit 246572.

Disassembly

1. Relieve Pressure, page 5.
2. Unplug sprayer from outlet.
3. Remove shroud (6 bolts).

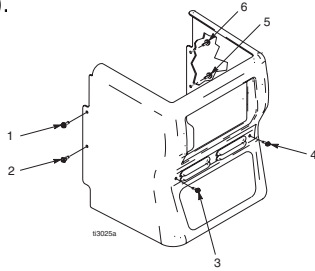

4. Remove RotoFlex Pump hose; page 6.
5. Remove Air Cylinder; page 10.
6. Cut wire tie (A).

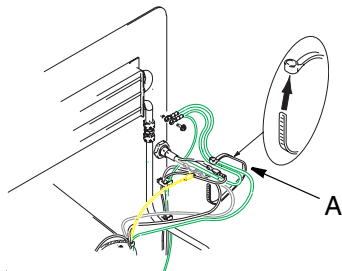

7. Remove yellow wire (B).

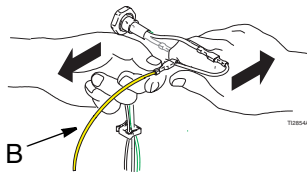

8. Remove ground nut (C).

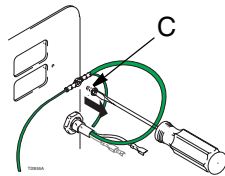

9. Remove blue wire to switch (D).

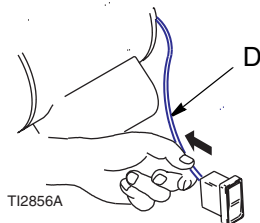

10. Using a flat screw driver, remove c-clip (E).

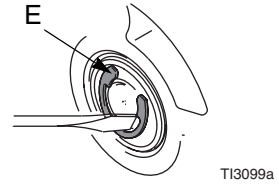

11. Using your hand to support the motor, carefully pull rod (F) out through back.

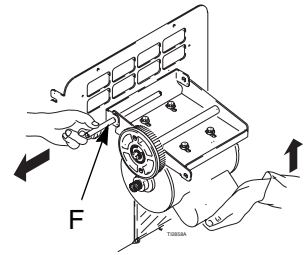

12. Bring motor to work-bench.

13. Remove 4 bolts (G) holding motor to bracket.

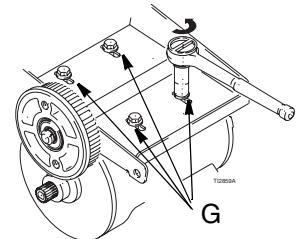

14. Cut wire tie. Remove capacitor from plate, page 11.

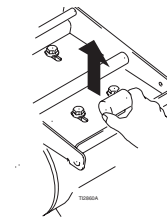

Reassembly

1. Reposition motor in housing, keeping motor square and aligned to pulley.
2. Keeping tension on belt, tighten 4 bolts (G). Torque to 15 ft-lbs.

The motor will have a tendency to move when bolts are being tightened. Hold it securely in place, square and aligned to pulley.

3. Secure new capacitor to plate, page 11.

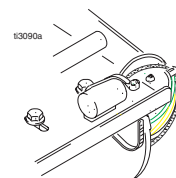

- Using one hand to support motor, slide rod (F) through motor bracket.

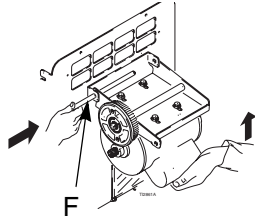

- Replace c-clip (E).

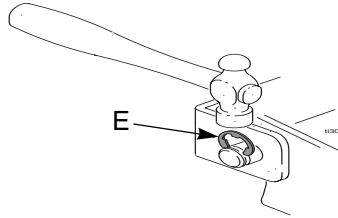

For steps 6-9 refer to illustration below Step 9.

- Reattach blue wire to switch (D).
- Replace ground nut (C).

- Reattach yellow wire (B).
- Secure all wires together with wire tie (A), making sure the wires do not touch air line (H) and the motor can swing the full travel (I) without stressing wires.

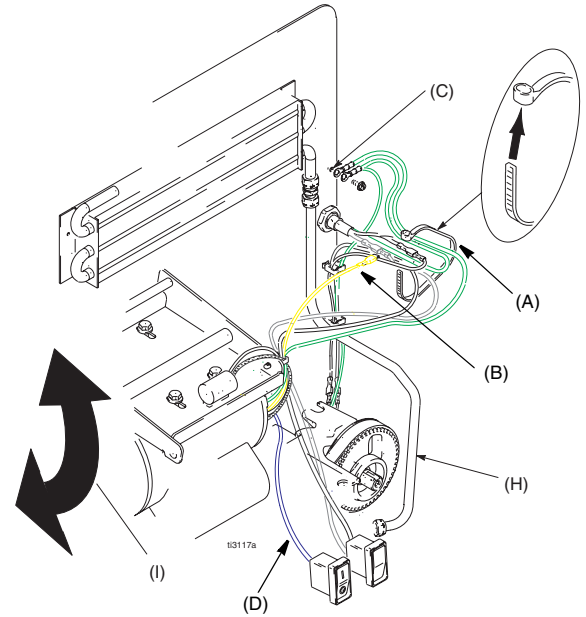

- Reconnect 3RotoFlex Pump hose, page 6.
- Replace shroud. Tighten bolts (6).

Cooler Repair

Use Cooler Repair Kit 246578.

Disassembly

1. **Relieve Pressure**, page 5.
2. Unplug sprayer.
3. Remove shroud (6 bolts).

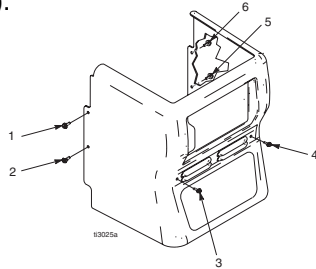

4. Loosen nuts (A and B).

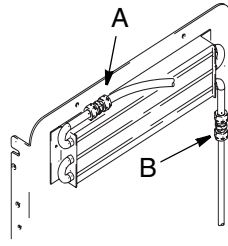

5. Disconnect air hose at fitting.

6. Carefully drill out rivets.

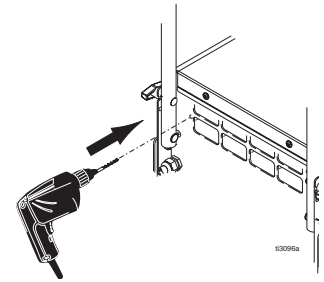

7. Pull cooler out of housing.

Reassembly

1. Install cooler in housing.
2. Rivet (or use fasteners) in place.

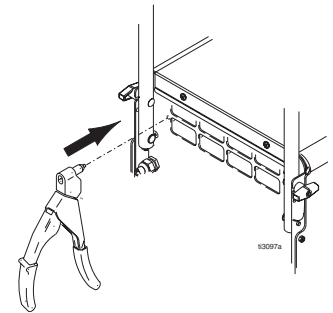

3. Reconnect tubing.
Torque nuts (A and B) one full turn beyond hand tight.
4. Replace shroud. Tighten bolts (6).

Relief Valve Replacement

Use Air Relief Valve Kit 246580, ZipTex 750.
Use Air Relief Valve Kit 246581, ZipTex 1000.

Disassembly

1. **Relieve Pressure**, page 5.
2. Unplug sprayer.
3. Remove shroud (6 bolts)

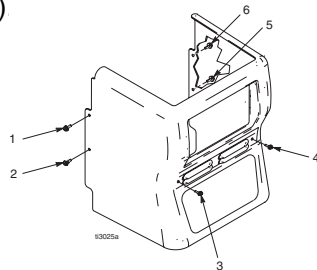

4. Remove screw on top of unit.
5. Remove air lines.

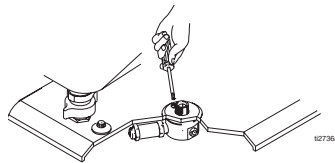

6. Pull air manifold down through inside of housing.

7. Disconnect air hose at quick disconnect fitting.

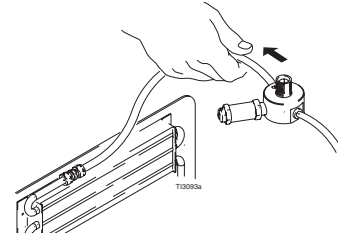

Reassembly

1. Reattach air hoses at quick disconnect fitting.

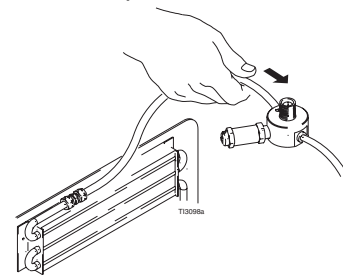

2. Slide air manifold back into position inside housing.

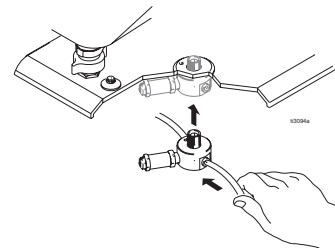

3. Replace screw on top of unit - torque to 30 in. lbs.
4. Replace shroud. Tighten bolts (6).

Rotor Replacement

Use Rotor Kit 246585 (includes Roller Kit 234214)

7. Remove rotor.

Disassembly

1. Relieve Pressure, page 5.
2. Unplug sprayer.
3. Remove shroud (6 bolts).
4. Remove RotoFlex pump hose, page 6, Disassembly, steps 4-8.
5. Remove rollers, page 9, Disassembly.
6. Using a flat screwdriver, remove c-clip (A).

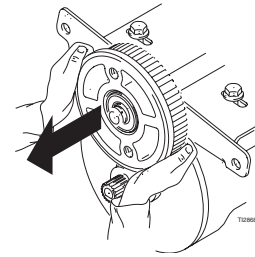
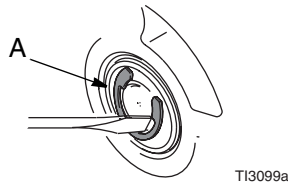
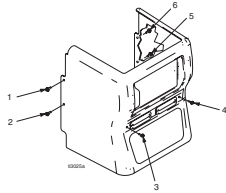

Reassembly

1. Install rotor with flange facing outward.
2. Replace c-clip (A).
3. Install rollers, page 9, Reassembly.
4. Install RotoFlex pump hose and shroud, page 7, Reassembly.

Troubleshooting



Pressure Relief, page 5

Problem	Cause	Solution
Sprayer won't run	Power switch not on	Turn switch on.
	No power at wall outlet	Check outlet by plugging in another appliance. If appliance does not work, try another outlet.
	Wrong size generator	Use a 3500 watt or larger generator. Refer to Generator Requirements, page 5
	Too many items on same circuit	Unplug other items from circuit
	Extension cord too long or wrong gauge	Use a different extension cord. Refer to Grounding and Electric Requirements, page 5
	Breaker tripped	Reset breaker
Pump won't pump material	Selector switch in wrong position	Move selector switch to correct position for application
	Air lock	Open air valve on gun
	Mix too thick	Add water to thin material. Use Material Thickness Gauge.
	Loose fittings	Check and retighten all fittings
	Plugged gun	Relieve Pressure , page 5. Remove gun from hose. Clean gun.
	RotoFlex pump worn out	Replace hose. Recommended hose replacement - once a year or every 3000 gallons.
	Pump cold or material frozen in pump	Move pump to warm room and allow it to warm up or run hot water through sprayer.
	Motor start capacitor failure	Replace capacitor and restart
Material runs out of bottom of sprayer	RotoFlex pump worn out	Replace hose
	Loose fittings	Check and retighten all fittings
No air from compressor	Gun air valve closed	Open gun air valve
	Low voltage	Check extension cord length and gauge. Replace if different than recommended. Refer to Grounding and Electrical Requirements, page 5.
	Gun needle plugged	Clean needle and retry.
	Lines not connected	Check all quick disconnect connections to gun and hoses
	Damaged hose	Replace hose
	Worn compressor	Replace compressor. Contact a qualified ASM Service Center.

Problem	Cause	Solution
Speed of application too slow	Material too thick	Thin material.
	Nozzle too small	Change nozzles to a larger size. See Operation Manual, Recommended Nozzle Selection Chart, page 10.
	Too much air being used.	Partially close gun air valve to reduce air flow.
	Flow control (Zip-Tex 1000 model) set too low	Increase flow control setting
	Plugged or dirty gun	Relieve Pressure , page 5. Clean gun.
	Kinked hose	Unkink hose.
	Gun fluid flow adjustment set too low	Increase flow adjustment with flow adjustment nut.
	RotoFlex pump worn	Replace hose.
Intermittent flow/sputtering	Hopper connection not tight	Check gasket. Tighten connection.
	Debris in system	Clean
Quick disconnect does not stay connected.	Dirty or corroded fitting	Clean thoroughly. Soak in oil. Apply a few drops of light oil.
Gun will not shut off	Worn nozzle or needle.	Relieve Pressure , page 5. Replace worn parts.
	Debris in needle passage	Relieve Pressure , page 5. Clean.
Fluid leaking at Flow Adjustment Nut	Damaged seal.	Relieve Pressure , page 5. Replace seal.
Fluid leaking out of either plug	Missing or damaged o-rings	Relieve Pressure , page 5. Replace o-rings.
	Gun damaged	Replace gun
Needle adjustment won't adjust	Dirty threads	Clean threads
	Nozzle not on gun	Put nozzle on gun

Wiring Diagram

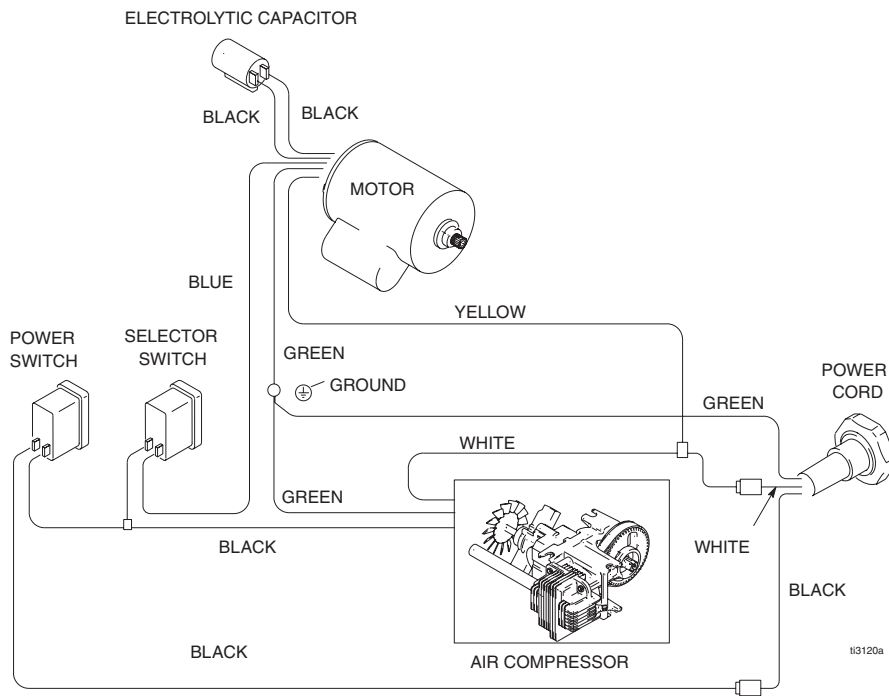

Air Diagram

ALTERNATE ZipTex 1000 CONFIGURATION FOR UNITS WITH REGULATOR DIAL AND GAUGE.

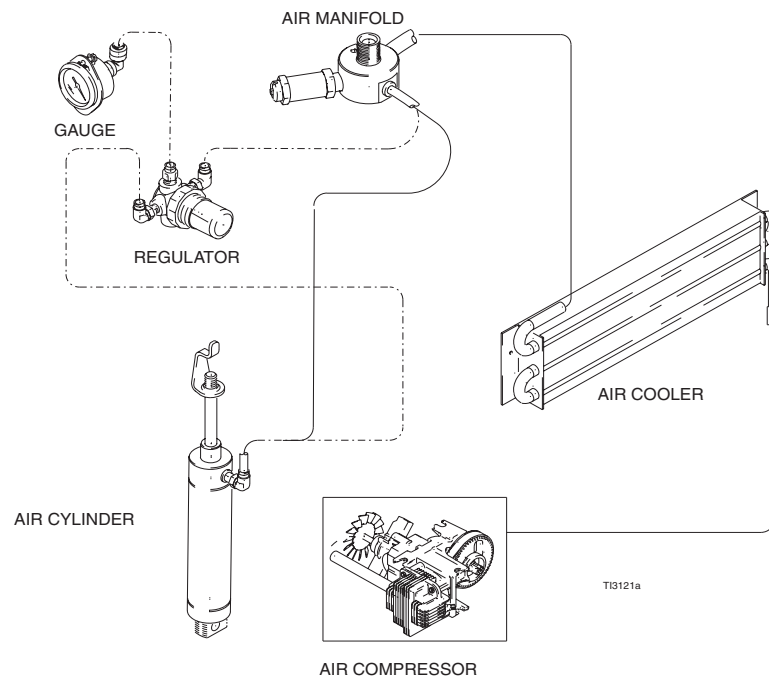

Parts

Model 246318, Zip-Tex 750

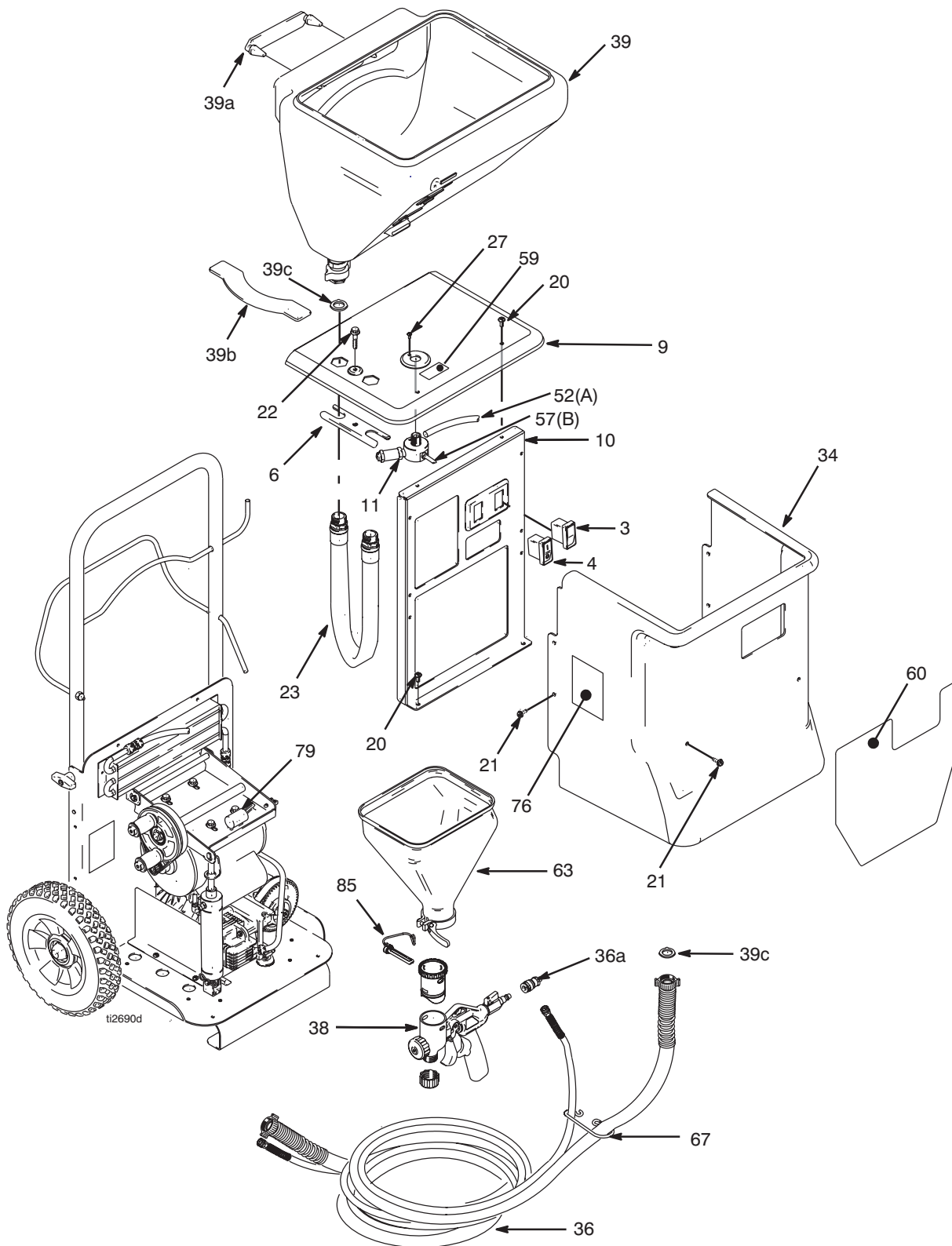

Parts

Model 246318, Zip-Tex 750

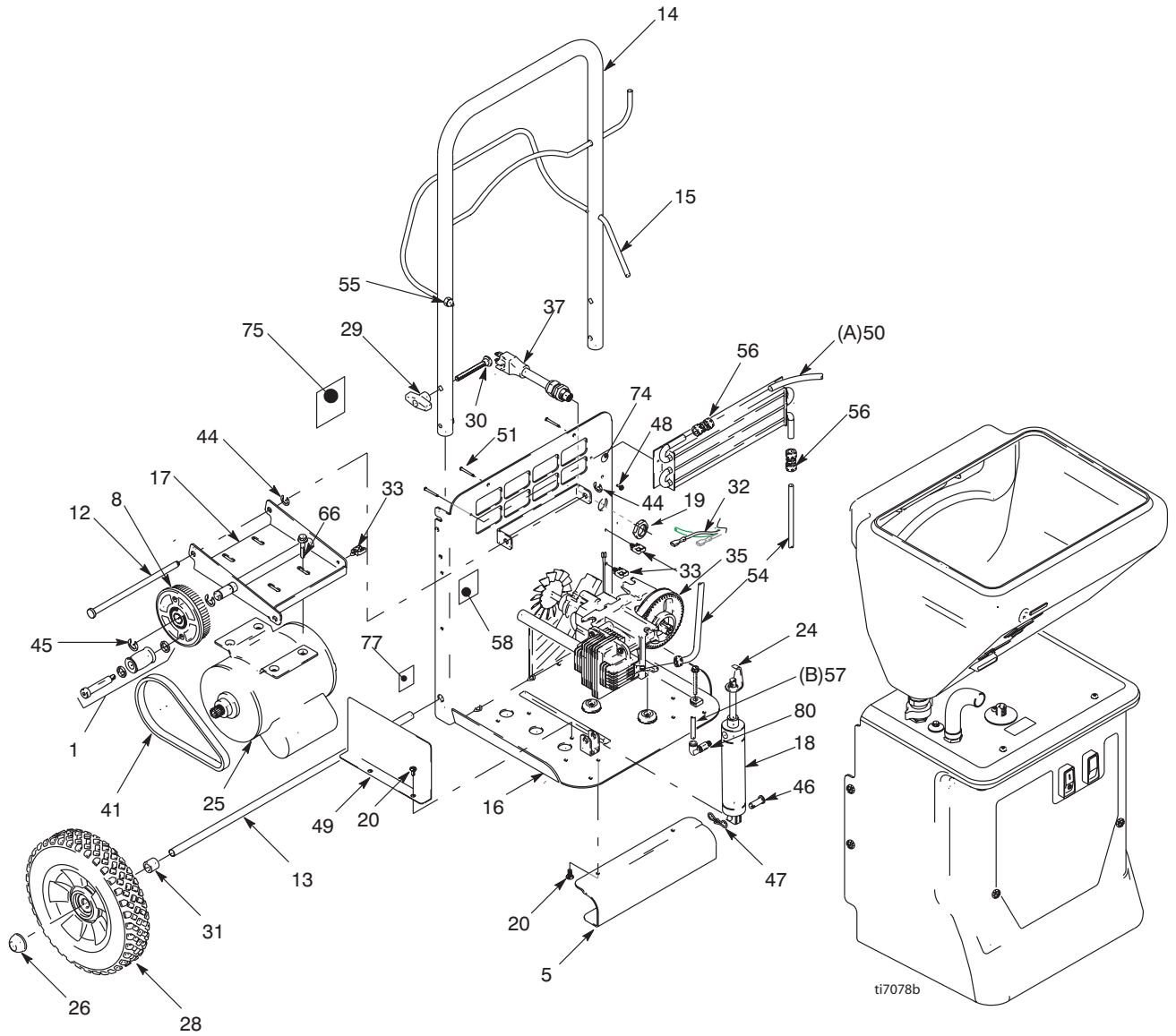

Parts

Model 246318, Zip-TEX 750

Ref No.	Part No.	Description	Qty	Ref No.	Part No.	Description	Qty
1	234214	KIT, roller	1	38	246545	GUN, texture, manual 309798	1
3	117563	SWITCH, selector	1	39	246316	HOPPER, 6-gallon	1
4	117693	SWITCH, on/off	1	39a	15B676	STORAGE, nozzle	1
5	15B859	LEG, frame	1	39b	15B990	GUARD, burp	1
6	15A903	PLATE, hose	1	39c	115099	GASKET	1
8	246585	KIT, pulley, includes 1, 2, 41	1	41	117672	BELT, GT2, 3mm	1
9	15B409	PLATE, frame, top	1	44	101134	RING, retaining, ext.	1
10	15B872	SUPPORT, front, frame	1	45	101242	RING, retaining, ext	2
11	246580	KIT, manifold, air, includes 19	1	46	117671	PIN, clevis	1
12	15B439	SHAFT, pivot, motor tray	1	47	117668	PIN, cotter, bow tie	1
13	15B530	ROD, axle	1	48	115498	SCREW, mch, hx wash hd	1
14	15B860	HANDLE,	1	49	15B786	SHIELD, spray	1
15	15B543	RACK, hose	1	50	246578	KIT, cooler, air, includes 51, 54, 56	1
16	15B856	FRAME, bottom	1	51	113084	RIVET, blind	2
17	246189	TRAY, motor	1	52	15B823	TUBE, air	1
18	246574	KIT, cylinder, air, includes 24, 46, 47	1	54	15B818	TUBE, air	1
19	117625	NUT, locking	1	55	115651	NUT, hex, acorn, 5/16-18	1
20	117630	SCREW, torx, tri-lob	8	56	117728	FITTING, compression, union	2
21	117633	SCREW, slot, hex wash hd	6	57	15B822	TUBE, air	1
22	117636	SCREW, hex hd, flanged	1	58▲	198492	LABEL, warning	1
23	234157	KIT, RotoFlex pump	1	59▲	290228	LABEL, caution	1
24	15B529	ARM, cylinder	1	60▲	15B895	LABEL	1
25	246572	KIT, motor, AC, includes 41, 66, 79	1	62	103473	STRAP, tie, wire	2
26	112612	CAP, hub	2	63	234222	HOPPER, texture, .75 gal	1
27	113415	SCREW, mach, torx pan hd	1	66	117791	SCREW, cap, tri-lobe	4
28	115095	WHEEL, 9"	2	67	15B986	CLIP, spring	1
29	115480	KNOB, t-handle	2	74▲	186620	LABEL, symbol, ground	1
30	116630	SCREW, carriage	2	75▲	15C127	LABEL, instruction	1
31	195367	SPACER	2	76▲	15C128	LABEL, danger	1
32	15B585	HARNES, wiring	1	77▲	292063	LABEL, identification	1
33	117727	CLIP, wire	3	78	15C090	GUAGE, material thickness	1
34	15B866	SHIELD	1	79	246683	KIT, capacitor	1
35	234211	KIT, compressor, air, includes 54	1	85	287967	CLIP, plug, gun	1
36	234148	KIT, hose	1				
36a	248930	KIT, quick disconnect	1				
37	15B507	CORD set, power	1				

▲ Replacement Danger and Warning labels, tags and cards are available at no cost.

Parts

Model 246319, Zip-Tex 1000

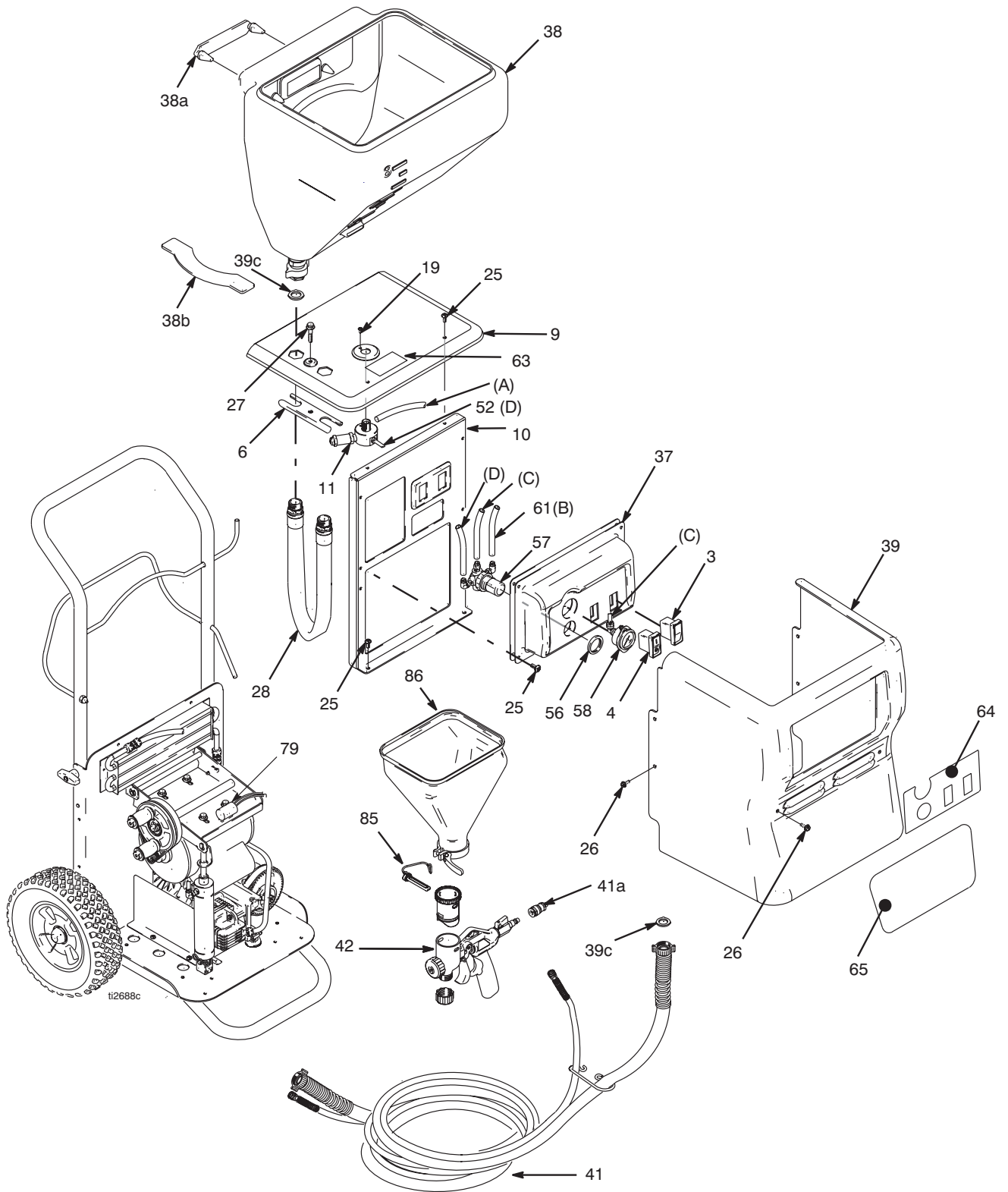

Parts

Model 246319, Zip-Tex 1000

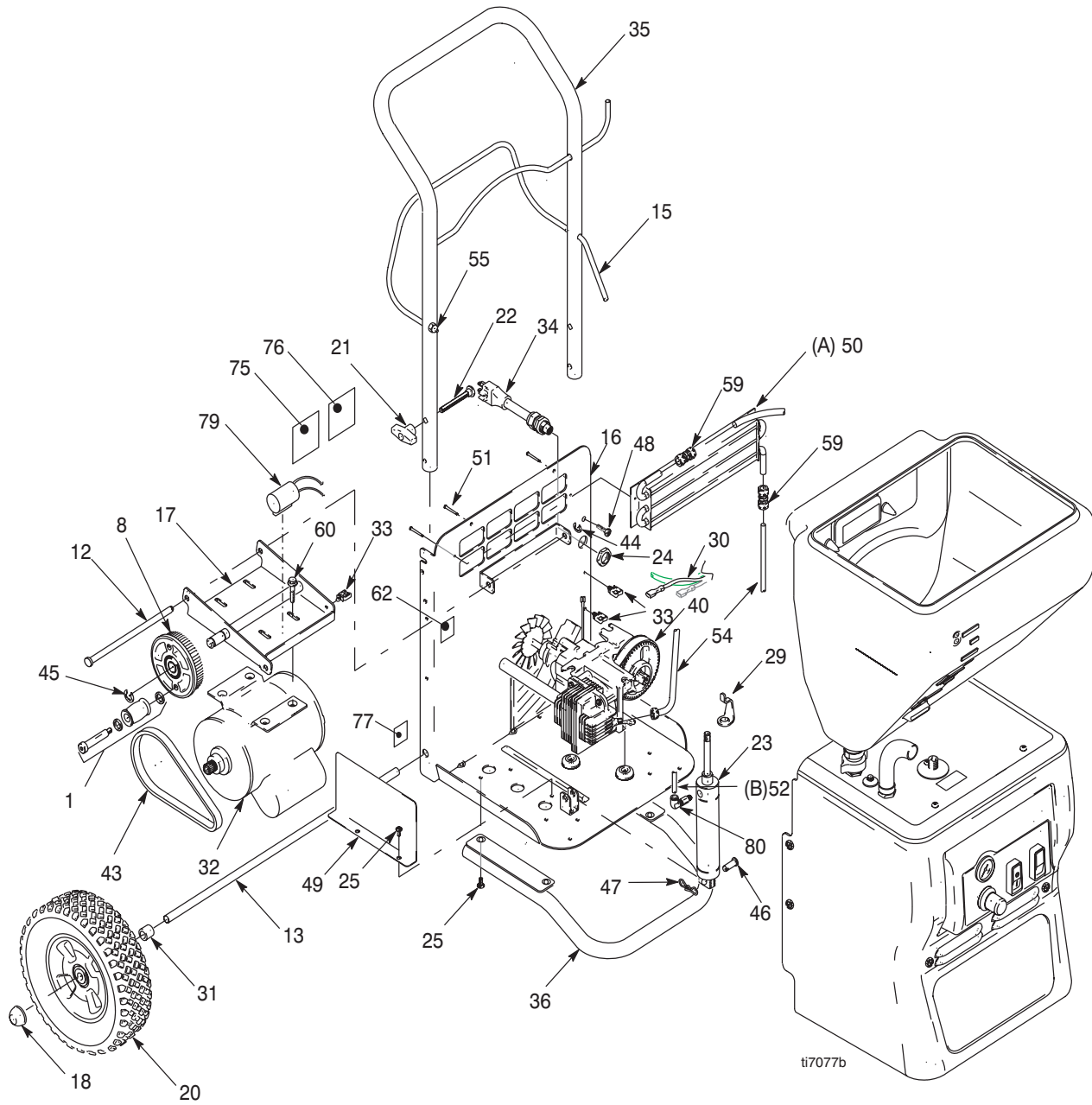

Parts

Model 246319, Zip-Tex 1000

Ref No	Part No.	Description	Qty	Ref No	Part No.	Description	Qty
1	234214	KIT, roller	1	41	234148	KIT, hose	1
3	117563	SWTICH, power	1	41a	248930	KIT, quick disconnect	1
4	117693	SWITCH, power	1	42	246545	GUN, spray, manual 309798	1
6	15A903	PLATE, hose	1	43	117672	BELT, GT2, 3mm	1
8	246585	KIT, pulley, includes 1, 2, 43	1	46	117671	PIN, clevis	1
9	15B409	PLATE, frame top	1	47	117668	PIN, cotter, bow tie	1
10	15B872	SUPPORT, front frame	1	48	115498	SCREW, mch, slot, hex	1
11	246581	KIT, manifold, air, includes 19	1	49	156783	SHIELD, spray	1
12	15B439	SHAFT, pivot, motor	1	50	246578	KIT, cooler, air, includes 51, 54, 59	1
13	15B590	ROD, axle	1	51	113084	RIVET, blind	2
15	15B543	RACK, hose	1	52	15B823	TUBE, air	1
16	15B856	FRAME, bottom	1	54	15B818	TUBE, air	1
17	246189	TRAY, motor	1	55	115651	NUT, hex, acorn 5/16-18	1
18	112612	CAP, hub	2	56	115244	NUT, regulator	1
19	113415	SCREW, mach, torx pan hd	1	57	115242	REGULATOR, air, 1/4 npt	1
20	115094	WHEEL, 10"	2	58	117720	GAUGE, pressure	1
21	115480	KNOB, t-handle	2	59	117728	FITTING, compression	2
22	116630	SCREW, carriage	2	60	117791	SCREW, motor	4
23	246575	KIT, cylinder, air, includes 29, 46, 47	1	61	15B822	TUBE, air	1
24	117625	NUT, locking	1	62▲	198492	LABEL, warning	1
25	117630	SCREW, torx, tri lob	16	63▲	290228	LABEL, caution	1
26	117633	SCREW, slot hex wash hd	6	64▲	15B886	LABEL, model, upper	1
27	117636	SCREW, hx hd, flanged	1	65▲	15B899	LABEL, model, lower	1
28	234157	KIT, RotoFlex pump	1	75▲	15C127	LABEL, instructions	1
29	15B529	ARM, cylinder	1	76▲	15C128	LABEL, danger	1
30	15B585	HARNESS, wiring	1	77▲	292063	LABEL, serial number	1
31	195367	SPACER	2		15C090	GAUGE, material thickness	1
32	246572	KIT, motor, AC, includes 43, 60, 79	1	79	246683	KIT, capacitor	1
33	117727	CLIP, wire	3	80	*113318	ELBOW	
34	15B507	CORD set, power	1		*104172	FITTING	
35	287051	HANDLE	1	85	287967	CLIP, plug, gun	1
36	15B541	LEG	1	86	234222	HOPPER, texture, .75 gal	1
37	15B542	PANEL, control	1				
38	246317	HOPPER, 8-gallon	1				
38a	15B676	STORAGE, nozzle	1				
38b	15B990	GUARD, burp	1				
38c	115099	GASKET	1				
39	15B868	SHIELD	1				
40	234211	KIT, compressor, includes 54, 59	1				

▲ Replacement Danger and Warning labels, tags and cards are available at no cost.

* When repairing elbow, order both part numbers listed for 80.

Technical Data

Main unit power requirements	120 Vac, 60 Hz, 15A, 1 phase
Maximum fluid working pressure	60 psi, (4.137 bar)
Maximum air working pressure	45 psi (3.10 bar)
Compressor specifications	Universal motor thermally protected, oil-less
Compressor air displacement	4.5 displacement scfm at 30 psi
Generator required	3500 W minimum
Electric Motor	
Material pump motor	Capacitor start, 1/3 hp AC, 2.8A open frame
Compressor motor	Universal AC 10.5A
Power Cord	16 AWG, 3-wire, 25 ft
Material hopper capacity	Model 246318: 6 gallons Model 246319: 8 gallons
	Gun material hopper: 3/4 gallon
Maximum delivery with texture	0.75 - 1.0 gpm (2.8 - 3.8 lpm)
Zip-Tex 750 Dimensions and Weight:	
Length	23 in. (584 mm) with handle
Width	23 in. (584 mm)
Height	39 in. (991 mm)
Weight without hoses or gun	75 lb (34 kg)
Zip-Tex 1000 Dimensions and Weight:	
Length	23 in. (584 mm) with handle
Width	24 in. (610 mm)
Height	42 in. (1067 mm)
Weight without hoses or gun	80 lb (36 kg)
Wetted parts	brass, aluminum, plastic
Sound data	
Sound pressure level*	83.2 dB(A)
Sound power level**	97.5 dB(A)
Storage Temperature Range	35°F - 160°F (1.6°C - 71°C)
Operating Temperature Range	40°F - 115°F (4°C - 46°C)
Gun:	
Maximum Working Pressure	60 psi (4.137 bar)
Air Maximum Working Pressure	100 psi (6.895 bar)
CFM Rating	3.5 - 11 CFM
Weight	1.1 lb (500 g)

* Measured while spraying at 1 m.

** Measured per ISO-3744

NOTES



A series of 25 horizontal lines for writing notes.

ASM Standard Warranty

ASM warrants all equipment referenced in this document which is manufactured by ASM and bearing its name to be free from defects in material and workmanship on the date of sale by an authorized ASM distributor to the original purchaser for use. With the exception of any special, extended, or limited warranty published by ASM, ASM will, for a period of twelve months from the date of sale, repair or replace any part of the equipment determined by ASM to be defective. This warranty applies only when the equipment is installed, operated and maintained in accordance with ASM's written recommendations.

This warranty does not cover, and ASM shall not be liable for general wear and tear, or any malfunction damage or wear caused by faulty installation, misapplication, abrasion, corrosion, inadequate or improper maintenance, negligence, accident, tampering, or substitution of non-ASM component parts. Nor shall ASM be liable for malfunction, damage, or wear caused by the incompatibility of ASM equipment with structures, accessories, equipment or materials not supplied by ASM, or the improper design, manufacture, installation, operation or maintenance of structures, accessories, equipment or materials not supplied by ASM.

This warranty is conditioned up the prepaid return of the equipment claimed to be defective to an authorized ASM distributor for verification of the claimed defect. If the claimed defect is verified, ASM will repair or replace free of charge any defective parts. The equipment will be returned to the original purchaser transportation prepaid. If inspection of the equipment does not disclose any defect in material or workmanship, repairs will be made at a reasonable charge, which charges may include the costs of parts, labor, and transportation.

THIS WARRANTY IS EXCLUSIVE, AND IS IN LIEU OF ANY OTHER WARRANTIES, EXPRESS OR IMPLIED, INCLUDING BUT NOT LIMITED TO WARRANTY OF MERCHANTABILITY OR WARRANTY OF FITNESS FOR A PARTICULAR PURPOSE.

ASM's sole obligation and buyer's sole remedy for any breach of warranty shall be set forth above. The buyer agrees that no other remedy (including, but not limited to, incidental or consequential damages for lost profits, lost sales, injury to person or property, or any other incidental or consequential loss) shall be available. Any action or breach of warranty must be brought within two (2) years of the date of sale.

ASM MAKES NOT WARRANTY, AND DISCLAIMS ALL IMPLIED WARRANTIES OF MERCHANTABILITY AND FITNESS FOR A PARTICULAR PURPOSE, IN CONNECTION WITH ACCESSORIES, EQUIPMENT, MATERIALS OR COMPONENTS SOLD BUT NOT MANUFACTURED BY ASM. These items sold, but not manufactured by ASM (such as electric motors, switches, hose, etc.), are subject to the warranty, if any, of their manufacturer. ASM will provide purchaser with reasonable assistance in making any claim for breach of these warranties.

In no event will ASM be liable for indirect, incidental, special or consequential damages resulting from ASM supplying equipment hereunder, or the furnishing, performance, or use of any products or other goods sold hereto, whether due to a breach of contract, breach of warranty, the negligence of ASM, or otherwise.

TO PLACE AN ORDER OR FOR SERVICE, contact your ASM distributor,
or call 1-800-854-4025 to identify the nearest distributor.

All written and visual data contained in this document reflects the latest product information available at the time of publication.

ASM reserves the right to make changes at any time without notice.

This manual contains English: MM 309800

ASM Company

3500 North 1st Avenue, Sioux Falls, SD 57104

www.asmcompany.com

PRINTED IN USA 1/2003, Rev. 3/2006