

Check-Mate[®] Pump Packages

312376E rev.e

For use with non-heated bulk supply of medium to high viscosity sealant and adhesive materials. Not for use in hazardous locations.

With priming piston and Severe Duty[®] or MaxLife[®] rod and cylinder.



Important Safety Instructions

Read all warnings and instructions in this manual.
Save these instructions.

See page 3 for model information. See page 32 for maximum working pressure and approvals.

P20LCM Model Shown

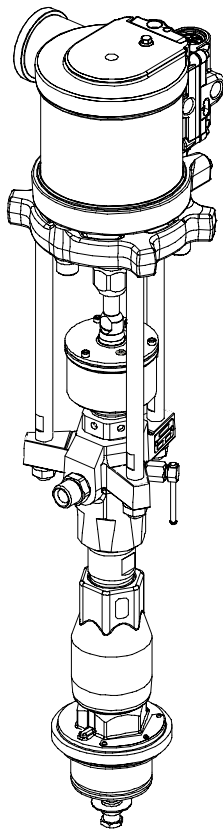

r_p20lcs_312376_1e

P39LCS Model Shown

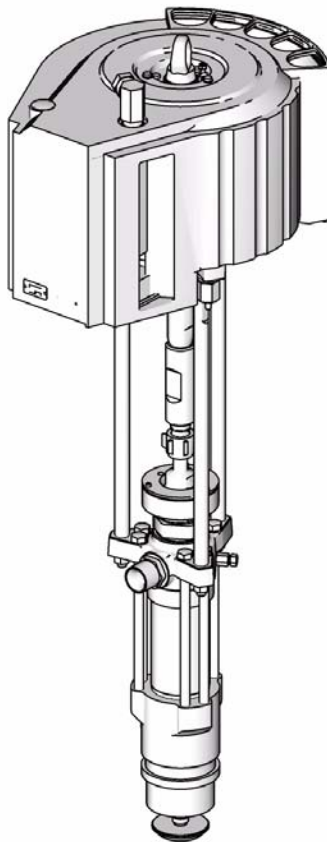

ti10715a

P40RCM Model Shown

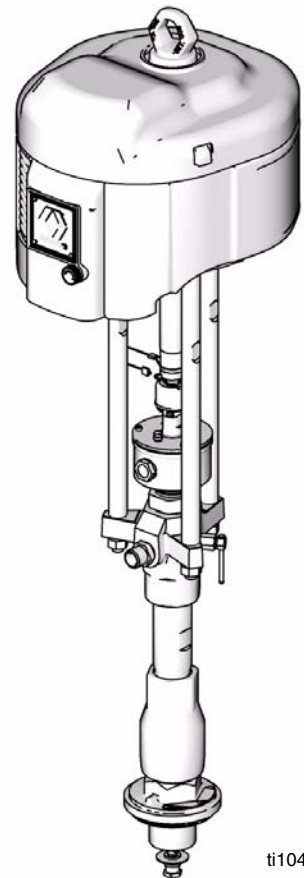

ti10420a



Contents

- Related Manuals** 2
- Models** 3
- Warnings** 4
- Component Identification, Supply Unit Installation** 6
- Component Identification, Typical Installation** ... 8
- Installation** 9
 - Grounding 9
 - System Accessories 10
- Setup** 11
 - Wet Cup 11
- Pressure Relief Procedure** 12
- Prime/Flush** 13
- Start Up and Adjust Pump** 13
- Shutdown** 15
 - Overnight Shutdown 15
- Troubleshooting** 16
- Repair** 18
 - Disconnect Displacement Pump 18
 - Reconnect Displacement Pump 20
- Parts** 22
 - Pump Packages Continued 23
 - Pump Packages with L060xx Displacement Pumps
24
 - Pump Packages with L100xx Displacement Pumps
26
 - Pump Packages with L200xx Displacement Pumps
27
 - Pump Packages with L250xx Displacement Pumps
28
 - Pump Packages with L500xx Displacement Pumps
29
- Dimensions** 30
- Technical Data** 32
- Performance Charts** 33
- Graco Standard Warranty** 40
- Graco Information** 40

Related Manuals

Component Manuals in U.S. English

Manual	Description
312375	Check-Mate® Displacement Pump Instructions-Parts
312889	60 cc Check-Mate Displacement Pump Repair Parts Manual
312467	100 cc Check-Mate Displacement Pump Repair Parts Manual
312468	200 cc Check-Mate Displacement Pump Repair Parts Manual
312469	250 cc Check-Mate Displacement Pump Repair Parts Manual
312470	500 cc Check-Mate Displacement Pump Repair Parts Manual
311238	2200-6500 NXT Air Motor Instructions-Parts
312796	200-1800 NXT Air Motor Instructions-Parts
308213	Premier™ Air Motor Instructions-Parts
313526	Supply Units Operation
313527	Supply Units Repair-Parts
313528	Tandem Supply Units Operation
313529	Tandem Supply Units Repair-Parts

Translations

The Check-Mate Pump Packages Instructions-Parts manual is available in the following languages. See the following chart for specific languages and corresponding part numbers.

Manual	Language
312711	Chinese
312712	French
312713	German
312714	Japanese
312715	Korean
312716	Portuguese
312717	Spanish

Models

Check your pump package’s identification (ID) plate (located on side of air motor) for the 6-digit part number of your pump package. Use the following matrix to define the construction of your pump package, based on the six digits. For example, pump package **P29RSM** represents the pump package (**P**); a pressure ratio of 29:1 with an NXT3400 motor and a 250cc displacement pump (**29**); a low noise motor with remote DataTrak (**R**); and a displacement pump constructed of stainless steel (**S**) with MaxLife® coatings, packings, and enclosed wet cup (**M**).

PART NO.		SERIAL	SERIES
MAX FLUID WPR		MAX AIR WPR	RATIO
MPa		MPa	
bar		bar	
PSI		PSI	

 GRACO INC.
 MPLS, MN
 Artwork 293287

ID plate located on side of air motor.





 Some configurations in the following matrix cannot be built. See the Product Selection Guide for available systems.





To order replacement parts, see **Parts** section starting on page 22. The digits in the matrix do not correspond to the Ref. Nos. in the Parts drawings and lists.

P	29			R		S		M	
First Digit	Second and Third Digits			Fourth Digits		Fifth Digit		Sixth Digit	
	Pressure Ratio (xx:1)	Motor	Displacement Pump Volume (cc)		Motor / Remote DataTrak		Displacement Pump Material		Coatings, Packings, Enclosed Wet Cup
P (pump)	05	NXT200	60	L	Low Noise; NO DataTrak	C	Carbon Steel	S	Severe Duty®
	11	NXT400	60	R	Low Noise; Remote DataTrak	S	Stainless Steel	M	MaxLife®
	14	NXT3400	500	M	Low Noise; Data Trak				
	20	NXT700	60	S	Low Noise, High Level Sensor				
	23	NXT2200	200						
	26	NXT6500	500						
	29	NXT3400	250						
	36	NXT3400	200						
	38	NXT1200	60						
	39	Premier	500						
	40	NXT2200	100						
	55	NXT6500	250						
	61	NXT1800	60						
	63	NXT3400	100						
	68	NXT6500	200						
82	Premier	250							

Warnings

The following warnings are for the setup, use, grounding, maintenance, and repair of this equipment. The exclamation point symbol alerts you to a general warning and the hazard symbol refers to procedure-specific risk. Refer back to these warnings. Additional, product-specific warnings may be found throughout the body of this manual where applicable.

 WARNING	
	<p>SKIN INJECTION HAZARD</p> <p>High-pressure fluid from gun, hose leaks, or ruptured components will pierce skin. This may look like just a cut, but it is a serious injury that can result in amputation. Get immediate surgical treatment.</p> <ul style="list-style-type: none"> • Do not point gun at anyone or at any part of the body. • Do not put your hand over the spray tip. • Do not stop or deflect leaks with your hand, body, glove, or rag. • Do not spray without tip guard and trigger guard installed. • Engage trigger lock when not spraying. • Follow Pressure Relief Procedure in this manual, when you stop spraying and before cleaning, checking, or servicing equipment.
	<p>MOVING PARTS HAZARD</p> <p>Moving parts can pinch or amputate fingers and other body parts.</p> <ul style="list-style-type: none"> • Keep clear of moving parts. • Do not operate equipment with protective guards or covers removed. • Pressurized equipment can start without warning. Before checking, moving, or servicing equipment, follow the Pressure Relief Procedure in this manual. Disconnect power or air supply.
	<p>FIRE AND EXPLOSION HAZARD</p> <p>Flammable fumes, such as solvent and paint fumes, in work area can ignite or explode. To help prevent fire and explosion:</p> <ul style="list-style-type: none"> • Use equipment only in well ventilated area. • Eliminate all ignition sources; such as pilot lights, cigarettes, portable electric lamps, and plastic drop cloths (potential static arc). • Keep work area free of debris, including solvent, rags and gasoline. • Do not plug or unplug power cords, or turn power or light switches on or off when flammable fumes are present. • Ground all equipment in the work area. See Grounding instructions. • Use only grounded hoses. • Hold gun firmly to side of grounded pail when triggering into pail. • If there is static sparking or you feel a shock, stop operation immediately. Do not use equipment until you identify and correct the problem. • Keep a working fire extinguisher in the work area.

 WARNING	
	<p>EQUIPMENT MISUSE HAZARD</p> <p>Misuse can cause death or serious injury.</p> <ul style="list-style-type: none"> • Do not operate the unit when fatigued or under the influence of drugs or alcohol. • Do not exceed the maximum working pressure or temperature rating of the lowest rated system component. See Technical Data in all equipment manuals. • Use fluids and solvents that are compatible with equipment wetted parts. See Technical Data in all equipment manuals. Read fluid and solvent manufacturer's warnings. For complete information about your material, request MSDS forms from distributor or retailer. • Check equipment daily. Repair or replace worn or damaged parts immediately with genuine manufacturer's replacement parts only. • Do not alter or modify equipment. • Use equipment only for its intended purpose. Call your distributor for information. • Route hoses and cables away from traffic areas, sharp edges, moving parts, and hot surfaces. • Do not kink or over bend hoses or use hoses to pull equipment. • Keep children and animals away from work area. • Comply with all applicable safety regulations.
	<p>ELECTRIC SHOCK HAZARD</p> <p>Improper grounding, setup, or usage of the system can cause electric shock.</p> <ul style="list-style-type: none"> • Turn off and disconnect power cord before servicing equipment. • Use only grounded electrical outlets. • Use only 3-wire extension cords. • Ensure ground prongs are intact on sprayer and extension cords. • Do not expose to rain. Store indoors.
	<p>TOXIC FLUID OR FUMES HAZARD</p> <p>Toxic fluids or fumes can cause serious injury or death if splashed in the eyes or on skin, inhaled, or swallowed.</p> <ul style="list-style-type: none"> • Read MSDS's to know the specific hazards of the fluids you are using. • Store hazardous fluid in approved containers, and dispose of it according to applicable guidelines. • Always wear impervious gloves when spraying or cleaning equipment.
	<p>PERSONAL PROTECTIVE EQUIPMENT</p> <p>You must wear appropriate protective equipment when operating, servicing, or when in the operating area of the equipment to help protect you from serious injury, including eye injury, inhalation of toxic fumes, burns, and hearing loss. This equipment includes but is not limited to:</p> <ul style="list-style-type: none"> • Protective eyewear • Clothing and respirator as recommended by the fluid and solvent manufacturer • Gloves • Hearing protection

Component Identification, Supply Unit Installation

CM14BA Model Shown

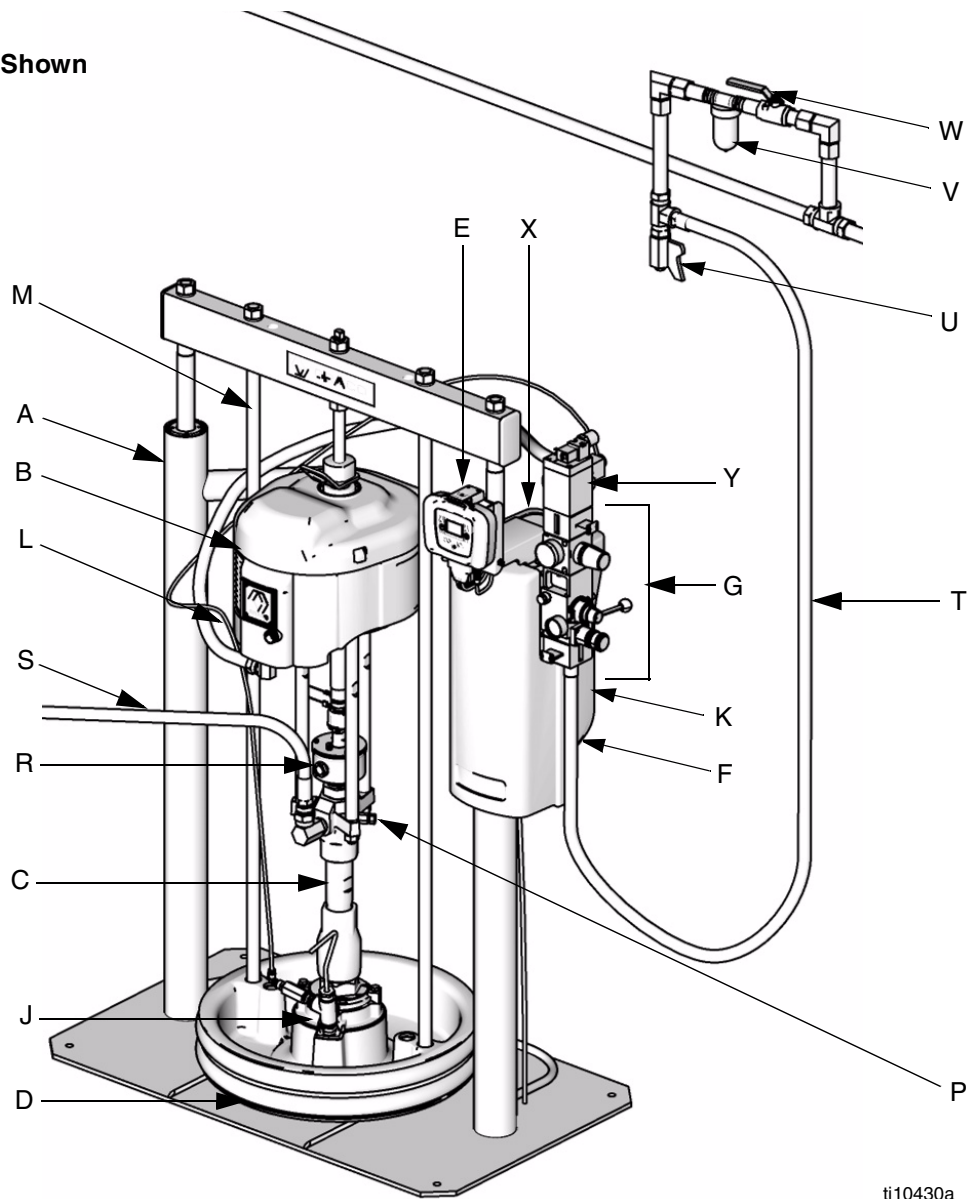

ti10430a

FIG. 1

Key:

- | | | | |
|---|---|---|--|
| A | Ram Assembly | M | Lift Rod |
| B | Air Motor | P | Pump Bleed Valve |
| C | Check-Mate Displacement Pump | R | Wet Cup |
| D | Platen | S | Fluid Line (not supplied) |
| E | Remote DataTrak (single systems) or Display Module (tandem systems) | T | Air Line (not supplied) |
| F | Fluid Control Module (tandem systems only; under shroud) | U | Air Line Drain Valve (not supplied) |
| G | Air Control Module | V | Air Filter (not supplied) |
| J | Platen Bleed Port | W | Air Shutoff Relief Valve (for accessories, not supplied) |
| K | Power Supply Box | X | Drum Low/Empty Sensor |
| L | Blowoff Air Supply Line | Y | Air Motor Solenoid |

CM7B1G Model Shown

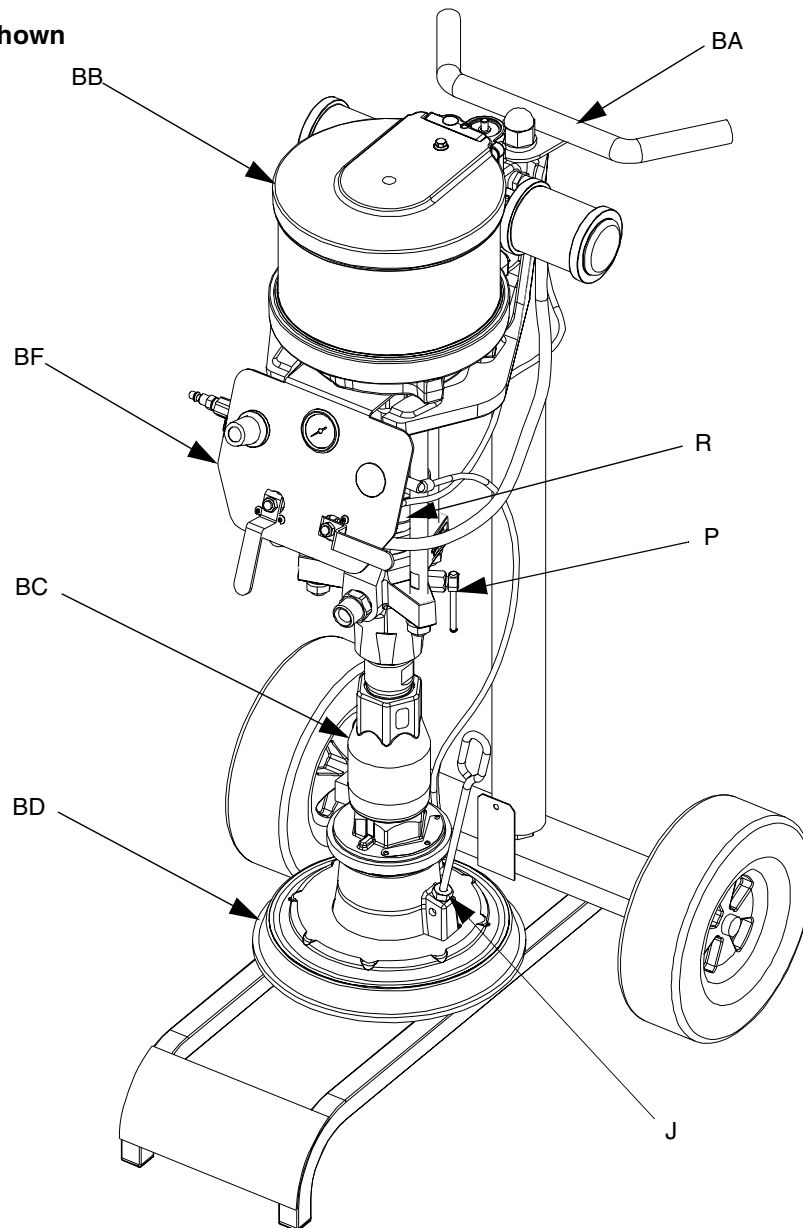

r_257032_312376_1e

FIG. 2

Key:

- BA Elevator Cart
- BB Air Motor
- BC Displacement Pump
- BD Platen
- BF Elevator and Pump Air Controls
- J Platen Bleed Port
- P Pump Bleed Valve
- R Wet Cup (behind air controls)

Component Identification, Typical Installation

P40RCM Model Shown

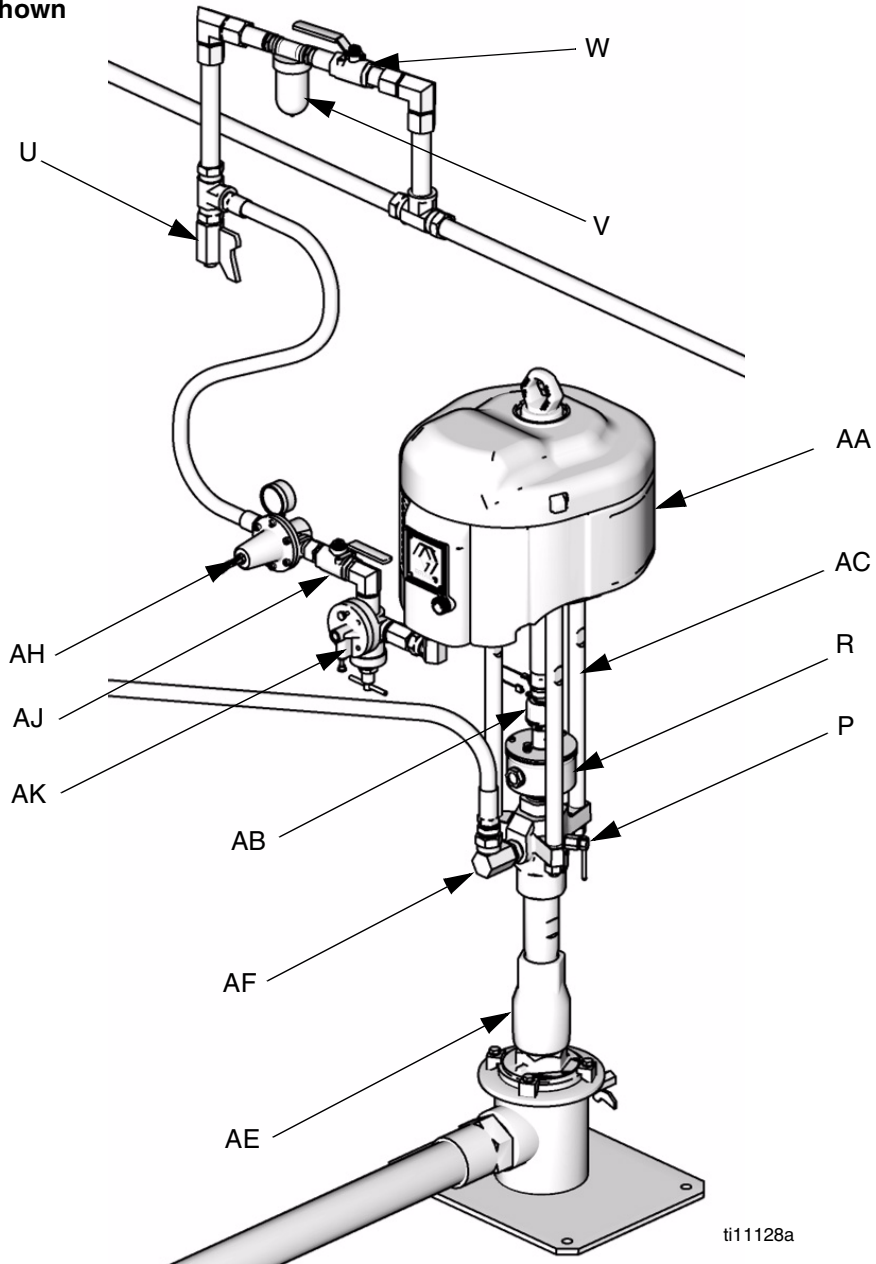

FIG. 3

Key:

- | | |
|-------------------------------|--|
| AA Air Motor | AK Pump Runaway Valve |
| AB Coupling Assembly | P Pump Bleed Valve |
| AC Tie Rods | R Wet Cup |
| AE Displacement Pump | U Air Line Drain Valve (not supplied) |
| AF Fluid Outlet | V Air Filter (not supplied) |
| AG Fluid Inlet (not shown) | W Air Shutoff Relief Valve (for accessories, not supplied) |
| AH Air Regulator | |
| AJ Bleed Type Air Motor Valve | |

Installation

Grounding

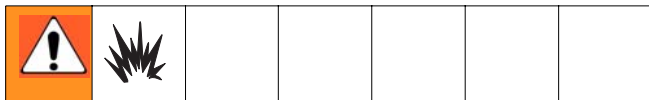

The equipment must be grounded. Grounding reduces the risk of static and electric shock by providing an escape wire for the electrical current due to static build up or in the event of a short circuit.

Pump: use a ground wire and clamp. Loosen the grounding lug locknut and washer. Insert one end of a 1.5 mm² (12 ga) minimum ground wire into the slot in lug and tighten the locknut securely. Connect the other end of the wire to a true earth ground. Order Part 237569 Ground Wire and Clamp.

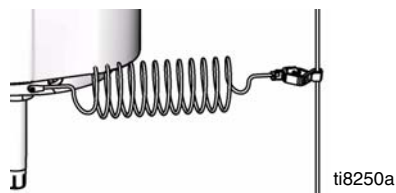

FIG. 4

Air and fluid hoses: use only electrically conductive hoses.

Air compressor: follow manufacturer's recommendations.

Spray gun/dispense valve: ground through connection to a properly grounded fluid hose and pump.

Fluid supply container: follow your local code.

Object being sprayed: follow your local code.

Solvent pails used when flushing: follow local code. Use only conductive metal pails, placed on a grounded surface. Do not place the pail on a nonconductive surface, such as paper or cardboard, which interrupts grounding continuity.

To maintain grounding continuity when flushing or relieving pressure: hold metal part of the spray gun/dispense valve firmly to the side of a grounded metal pail, then trigger the gun/valve.

System Accessories



A main air bleed valve and pump bleed valve (P) are required. These accessories help reduce the risk of serious injury, including fluid injection and splashing of fluid in the eyes or on the skin, and injury from moving parts if you are adjusting or repairing the pump.

The main air shutoff valve shuts off the air to the pump and ram. The air motor valve relieves air trapped between this valve and the pump after the air is shut off. Trapped air can cause the pump to cycle unexpectedly. Locate the valve close to the pump.

The pump bleed valve assists in relieving fluid pressure in the displacement pump, hose, and gun/valve. Triggering the gun/valve to relieve pressure may not be sufficient.

 If using Check-Mate pump with Graco Supply Systems, refer to Supply Systems Operation manual for system accessory installation instructions.

For use with all other systems, use this section for accessory installation instructions.

Be sure all air lines (T) and fluid lines (S) are properly sized and pressure-rated for your system. Use only electrically conductive hoses. Fluid hoses must have spring guards on both ends.

Mounting Accessories

Mount the pump package to suit the type of installation planned. Pump dimensions are shown on page 30. Refer to Check-Mate Displacement Pump manual 312375 for mounting hole layout.

Air Line Accessories

Install the following accessories as listed. Refer to FIG. 1 to see air line accessories represented in a typical supply unit installation.

- **Main air shutoff valve (W)** isolates the air line accessories for servicing. Locate upstream from all other air line accessories.

- **Air line filter (V)** removes harmful dirt and moisture from the compressed air supply. Also, install a drain valve at the bottom of each air line drop, to drain off moisture.
- **Air regulator (G and AH)** controls pump speed and outlet pressure by adjusting the air pressure to the pump. Locate the regulator close to the pump, but upstream from the bleed-type master air valve.
- **Air motor valve (AJ)** is required in your system to shut off the air supply to the pump (see WARNING). When closed, the valve will bleed off all air in the pump. Be sure the valve is easily accessible from the pump.
- **Pump runaway valve (AK)** senses when the pump is running too fast and automatically shuts off the air to the motor. A pump which runs too fast can be seriously damaged. Locate in the position shown.
- **Pump bleed valve (P)** is required in your system to relieve fluid pressure in hose and gun (see WARNING).

Fluid Line Accessories

Install the following accessories as listed. Refer to FIG. 2 to see fluid line accessories represented in a typical supply unit installation.

- Install a **fluid shutoff valve** at each gun/valve drop, to isolate the gun/valve and fluid accessories for servicing.
- Install a **fluid drain valve** near the pump fluid outlet, and at each gun/valve station. The drain valves are required in your system to relieve fluid pressure in the displacement pump, hose and gun/valve (see WARNING). Drain valves at the gun/valve stations may be mounted in the base of a fluid regulator, using an adapter.
- **Fluid regulator** controls fluid pressure to the gun/valve, and dampens pressure surges.
- **Gun or dispense valve** dispenses the fluid.
- **Gun/valve swivel** allows freer gun/valve movement.

Setup

Wet Cup

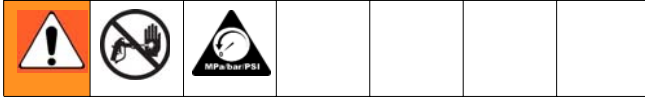

Before starting, fill the wet cup (R) 1/3 full with Graco Throat Seal Liquid (TSL) or compatible solvent.

 The enclosed wet cup has a fill port in the cover.

Torque Wet Cup

The wet cup is torqued at the factory; however, throat packing seals on Severe Duty pumps may relax over time. Check wet cup torque frequently after initial start-up and periodically after the first week of production. Maintaining proper wet cup torque is important to extending seal life.

 MaxLife pumps use a special u-cup throat seal that is non-adjustable and does not require periodic torquing.

To torque the wet cup, use the following steps.

1. Follow **Pressure Relief Procedure** on page 12.
2. Use the packing nut wrench (supplied) to torque the wet cup; see the following table for torque values. Do this whenever necessary. Do not overtighten the wet cup.

Displacement Pump	Torque
100cc, 60cc	28-44 ft-lbs (38-59 N•m)
200c, 250cc, 500cc	95-115 ft-lbs (128-155 N•m)

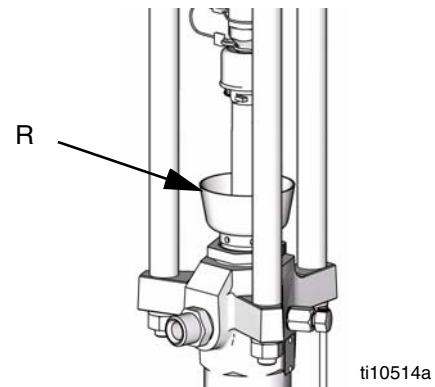
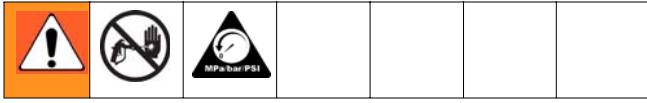

FIG. 5

Pressure Relief Procedure



1. Lock the gun/valve trigger.
2. **For D200s, D200, D60 and S20 Air Controls:** See FIG. 6.
 - a. Close the air motor slider valve and the main air slider valve.
 - b. Set the ram director valve to DOWN. The ram will slowly drop.
 - c. Jog the director valve up and down to bleed air from ram cylinders.

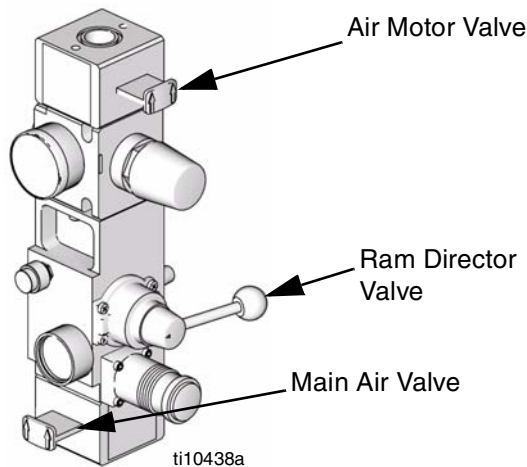

FIG. 6: Air Control Module

3. **For L20c Air Controls:** See FIG. 7.
 - a. Close the air motor valve and the elevator director valve. The ram will slowly drop.

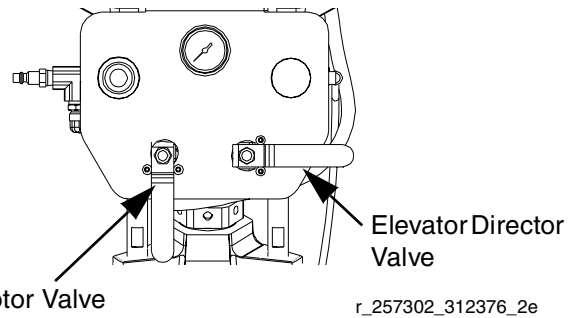

FIG. 7: L20c Air Control Panel

4. Unlock the gun/valve trigger.
5. Hold a metal part of the gun/valve firmly to the side of a grounded metal pail, and trigger the gun/valve to relieve pressure.
6. Lock the gun/valve trigger.
7. Open the fluid line drain valve and the pump bleed valve (P). Have a container ready to catch the drainage.
8. Leave the pump bleed valve open until ready to spray again.

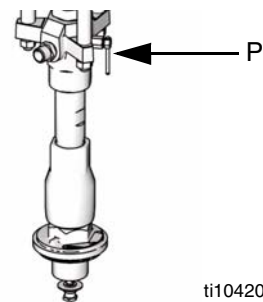
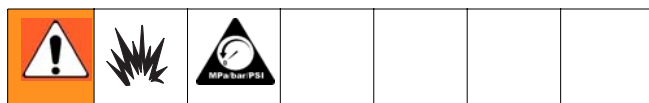



FIG. 8

If you suspect that the spray tip/nozzle or hose is completely clogged, or that pressure has not been fully relieved after following the steps above, very slowly loosen the tip guard retaining nut, nozzle, or hose end coupling and relieve pressure gradually, then loosen completely. Now clear the tip/nozzle or hose.

Prime/Flush



 The pump is tested with lightweight oil, which is left in to protect the pump parts. If the fluid you are using may be contaminated by the oil, flush it out with a compatible solvent before using the pump.

Flush with a fluid that is compatible with the fluid you are pumping and with the wetted parts in your system. Check with your fluid manufacturer or supplier for recommended flushing fluids and flushing frequency. Always flush the pump before fluid dries on the displacement rod.

CAUTION

Never leave water or water-based fluid in a carbon steel pump overnight. If you are pumping a water-based fluid, flush with water first. Then flush with a rust inhibitor, such as mineral spirits. Relieve pressure, but leave rust inhibitor in pump to protect parts from corrosion.

1. Follow **Pressure Relief Procedure** on page 12.
2. Remove the spray tip/nozzle from the gun/valve.
3. Hold a metal part of the gun/valve firmly to the side of a grounded metal pail.
4. Start the pump. Always use the lowest possible fluid pressure when flushing.
5. Trigger the gun/valve.
6. Flush the system until clear solvent flows from the gun/valve.
7. Relieve the pressure.

Start Up and Adjust Pump

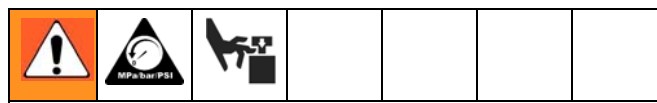

Keep hands and fingers away from the priming piston during operation and whenever the pump is charged with air. The priming piston extends beyond the intake housing to pull material into the pump and can amputate a hand or finger caught between it and the intake housing. Follow the **Pressure Relief Procedure** on page 12 before checking, clearing, or cleaning the priming piston.

1. Supply fluid to the pump, per the requirements of your system.
2. Be sure the pump air regulator is closed.
3. **For D200s, D200, D60, and S20 Air Controls:**
 - a. Set ram air regulator to about 50 psi (3.5 bar).
 - b. Set the ram director valve to down.

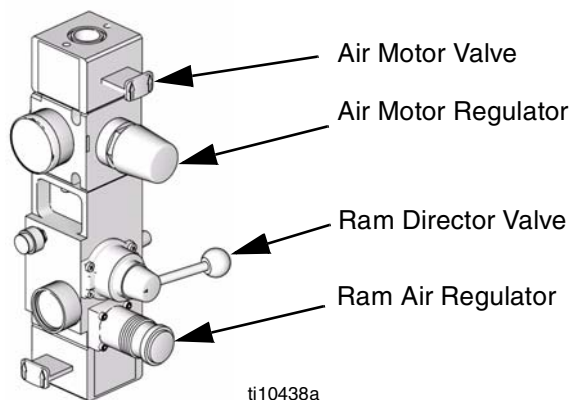

Fig. 9: D200s, D200,D60, and S20 Systems

4. **For L20c Air Controls:**

- a. Close elevator director valve. The ram will slowly drop.
- b. If necessary, press blowoff push button to pause elevator descent.

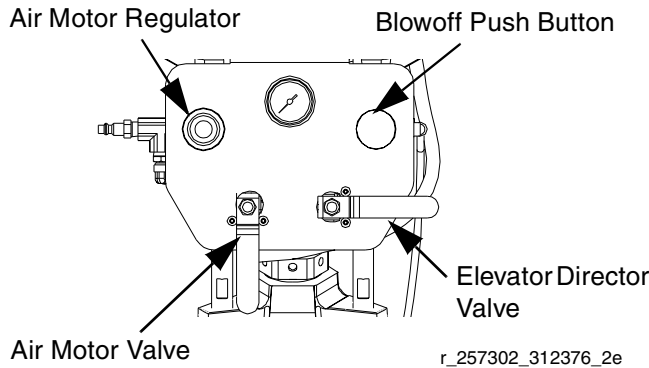

FIG. 10: L20c Air Controls

5. Reduce the air motor regulator pressure and open the air motor valve.
6. Adjust air motor regulator until the pump starts.
7. Cycle the pump slowly until all air is pushed out and the pump and hoses are fully primed.
8. Release the gun/valve trigger and lock the trigger safety. The pump should stall against pressure.

<p>To reduce the risk of fluid injection, do not use your hand or fingers to cover the bleed hole on the underside of the bleed valve body (P) when priming the pump. Use the handle or a crescent wrench to open and close the bleed plug. Keep your hands away from the bleed hole.</p>							

9. If the pump fails to prime properly, open the pump bleed valve (P) slightly. Use the bleed hole, on the underside of the valve, as a priming valve until the fluid appears at the hole. Close the plug.

Always use lowest possible fluid pressure to bleed air out of pump.

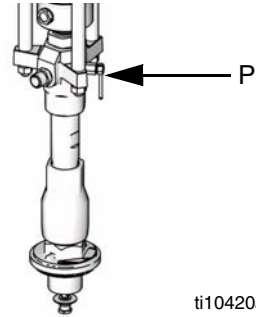

FIG. 11

When changing fluid containers with the hose and gun/valve already primed, open the pump bleed valve (P), to help prime the pump and vent air before it enters the hose. Close the valve when all air is eliminated.

CAUTION
<p>Do not allow the pump to run dry. It will quickly accelerate to a high speed, causing damage. If your pump is running too fast, stop it immediately and check the fluid supply. If the container is empty and air has been pumped into the lines, refill the container and prime the pump and the lines, or flush and leave it filled with a compatible solvent. Eliminate all air from the fluid system.</p>

10. With the pump and lines primed, and with adequate air pressure and volume supplied, the pump will start and stop as you open and close the gun/valve. In a circulating system, the pump will speed up or slow down on demand, until the air supply is shut off.

--	--	--	--	--	--	--	--

11. Use the air motor regulator (see FIG. 10) to control the pump speed and the fluid pressure. Always use the lowest air pressure necessary to get the desired results. Higher pressures cause premature tip/nozzle and pump wear.

Shutdown

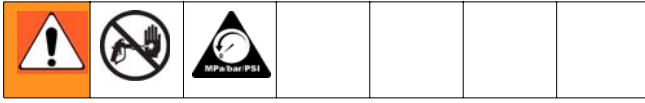

CAUTION

Never leave water or water-based fluid in a carbon steel pump overnight. If you are pumping water-based fluid, flush with water first, then with a rust inhibitor, such as mineral spirits. Relieve pressure, but leave rust inhibitor in pump to protect parts from corrosion.

Overnight Shutdown

1. Stop the pump at the bottom of the stroke to prevent fluid from drying on the exposed displacement rod and damaging the throat packings.
2. **For D200s, D200, D60, and S20 Supply Systems:** Set the ram director valve to the neutral position.
3. **For L20c Supply Systems:** Set the elevator director valve to DOWN.

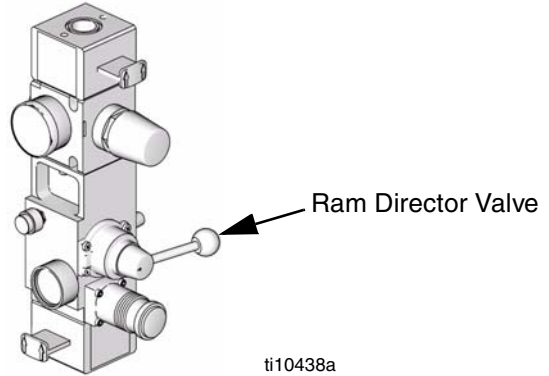

FIG. 12: D200s, D200, D60, and S20 Air Controls

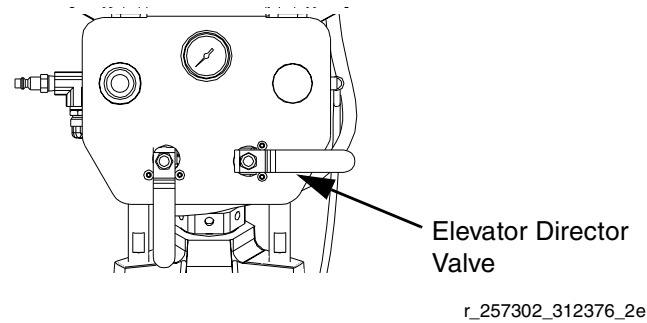

FIG. 13: L20c Air Controls

4. Follow **Pressure Relief Procedure**, page 12.
5. Always flush the pump before the fluid dries on the displacement rod. See **Prime/Flush** on page 13.

Troubleshooting



1. Follow **Pressure Relief Procedure**, page 12.
2. Check all possible problems and causes before disassembling pump.

Problem	Cause	Solution
Pump fails to operate.	Restricted line or inadequate air supply; closed or clogged valves.	Clear; increase air supply. Ensure that all valves are open.
	Obstructed fluid hose or gun/valve; fluid hose ID is too small.	Open, clear*; use a hose with a larger ID.
	Fluid dried on displacement rod.	Clean. Always stop pump at bottom of stroke. Keep enclosed wet cup 1/3 filled with a compatible solvent.
	Dirty, worn, or damaged motor parts.	Clean or repair; see separate motor manual.
	Runaway occurred.	See runaway section of Supply Units Operation manual 313526.
Pump operates but output is low on both strokes.	Restricted line or inadequate air supply; closed or clogged valves.	Clear; increase air supply. Ensure all valves are open. Increase air pressure to ram for better loading.
	Obstructed fluid hose or gun/valve; fluid hose ID is too small.	Open, clear*; use a hose with a larger ID.
	Bleed-type air valve is partially open.	Close bleed-type air valve.
	Air is leaking into supply container.	Check ram plate seal.
	Fluid is too heavy for pump priming.	Use drain/purge valve. Use a ram. See Supply Units Operation manual 313526.
	Held open or worn intake valve or seals.	Clear valve; replace seals. See separate Check-Mate Displacement Pump manual 312375.
	Worn packings in displacement pump.	Replace packings. See separate Check-Mate Displacement Pump manual 312375.
	Pump operates, but output is low on downstroke.	Fluid is too heavy for pump priming.
Held open or worn intake valve or seals.		Clear valve. Replace seals. See separate Check-Mate Displacement Pump manual 312375.
Pump operates, but output is low on upstroke.	Held open or worn intake valve or seals.	Clear valve. Replace seals. See separate Check-Mate Displacement Pump manual 312375.

Problem	Cause	Solution
Erratic or accelerated pump speed.	Exhausted fluid supply.	Refill and prime.
	Fluid is too heavy for pump priming.	Use drain/purge valve. Use a ram. See Supply Units Operation manual 313526.
		Increase ram air pressure.
	Held open or worn intake valve or seals.	Clear valve. Replace seals. See separate Check-Mate Displacement Pump manual 312375.
	Held open or worn priming piston.	Clear; service. See separate Check-Mate Displacement Pump manual 312375.
Worn packings in displacement pump.	Replace packings. See separate Check-Mate Displacement Pump manual 312375.	

* To determine if fluid hose or gun is obstructed, follow **Pressure Relief Procedure**, page 12. Disconnect fluid hose and place a container at pump fluid outlet to catch any fluid. Turn on air just enough to start pump. If pump starts when air is turned on, the obstruction is in the fluid hose or gun.

Repair

Required Tools

- Torque wrench
- Hammer
- Packing nut wrench (supplied with displacement pump)
- Set of socket wrenches
- Set of adjustable wrenches
- Loctite® 2760™ or equivalent
- Brass rod (pumps with 500cc displacement pumps only)
- Torque wrench with claw foot (pumps with 60cc and 500cc displacement pumps only)

Disconnect Displacement Pump



Keep hands and fingers away from the priming piston during operation and whenever the pump is charged with air to reduce the risk of injury. On the pump downstroke the priming piston extends beyond the intake housing to pull the material into the pump. The priming piston works under extreme force. During operation and whenever the pump is charged with air, the priming piston can severely injure or amputate a hand or finger, or break a tool, caught between it and the intake housing. Always relieve the pressure before checking, clearing, cleaning, flushing, or servicing any part of the pump.

On Premier air-powered pumps, the rocker arms (located beneath the rocker arm covers) move when air is supplied to the motor. Never operate the pump with the rocker arm covers removed.

1. Flush pump; see **Prime/Flush**, page 13. Stop pump at bottom of its stroke. Follow **Pressure Relief Procedure**, page 12.
2. Disconnect air hose.

 If your system includes a remote DataTrak, disconnect the air motor harness from the motor as well.

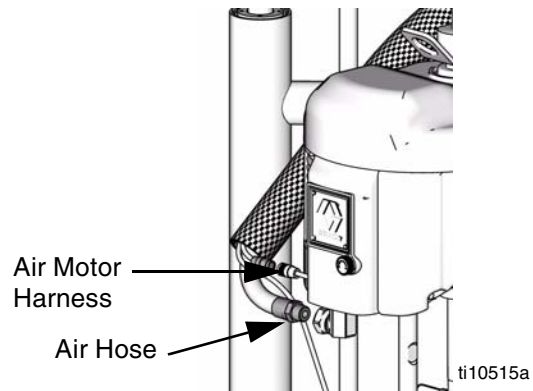

FIG. 14

3. Disconnect fluid hose. Hold fluid outlet fitting with a wrench to keep it from being loosened while you disconnect fluid hose.

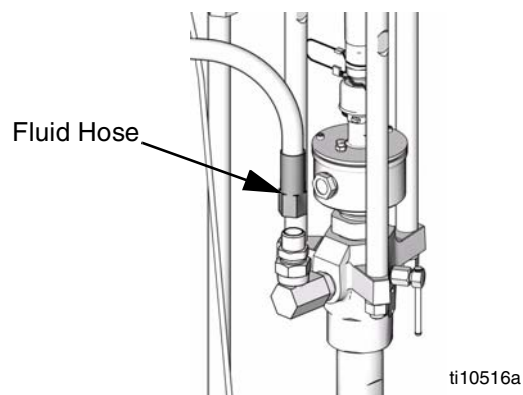

FIG. 15

4. Remove platen from displacement pump. Refer to Supply Units Repair-Parts manual 313527 for instructions.

CAUTION

Be sure to use at least two people when lifting, moving, or disconnecting the pump. This pump is too heavy for one person. If you are disconnecting the displacement pump from a motor that is still mounted (for example, on a ram), be sure to support the displacement pump while it is being disconnected, to prevent it from falling and causing injury or property damage. Do this by securely bracing the displacement pump, or by having at least two people hold it while another disconnects it.

5. If the air motor does not require servicing, leave it attached to its mounting. However, if the air motor does need to be removed, refer to the Supply Units Repair-Parts manual 313527 for instructions.
6. *Pumps with 100cc, 200cc, and 250cc displacement pumps only:* Remove clip (9), and slide coupling cover (8) up to remove coupling (7).

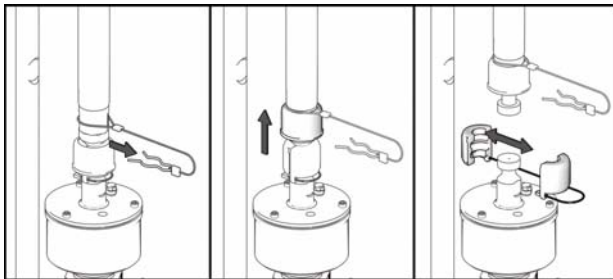

ti10508a

FIG. 16

7. *Pumps with 500cc displacement pumps only:* Use a hammer and brass rod to loosen coupling nut (8). When coupling nut drops down remove coupling collars (7) and coupling nut from displacement rod.

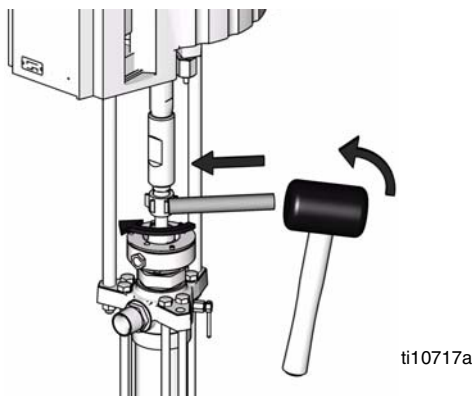

ti10717a

FIG. 17

8. *Pumps with 60cc displacement pumps only:* Use two wrenches to loosen coupling nut (8). When coupling nut drops down remove coupling collars (7) and coupling nut from displacement rod.
9. Use a wrench to hold the tie rod flats to keep the rods from turning. Unscrew the nuts (5) from the tie rods (3) and carefully remove the displacement pump (2).

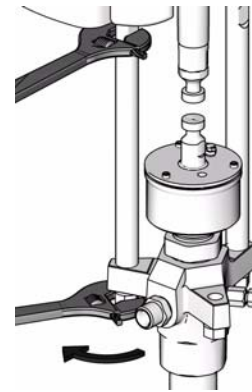

ti10510a

FIG. 18

10. Refer to the Check-Mate Displacement Pump manual 312375 to service the displacement pump. To service the air or hydraulic motor, refer to the separate motor manual, supplied.

Reconnect Displacement Pump

CAUTION

Be sure to use at least two people when lifting, moving, or connecting the pump. This pump is too heavy for one person. If you are connecting the displacement pump to a motor that is still mounted (for example, on a ram), be sure to support the displacement pump while it is being connected, to prevent it from falling and causing injury or property damage. Do this by securely bracing the displacement pump, or by having at least two people hold it while another connects it.

On Premier models, ensure that the rod adapter (6) has not loosened during maintenance. Proper torque is necessary to prevent the rod adapter from loosening during the pump operation.

If the rod adapter (6) has loosened during maintenance, remove the adapter and apply Loctite 2760 (or equivalent) to the rod adapter and air motor piston threads, and then torque to 230-250 ft-lbs (312-340 N•m).

1. If the air motor was removed, refer to the Supply Units Repair-Parts manual for installation instructions.
2. Use caution when reconnecting displacement pump. Place displacement pump (2) on tie rods (3).
3. Screw nuts (5) onto tie rods (3) and torque to 50-60 ft-lb (68-81 N•m).

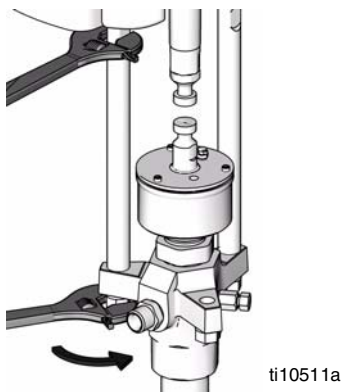
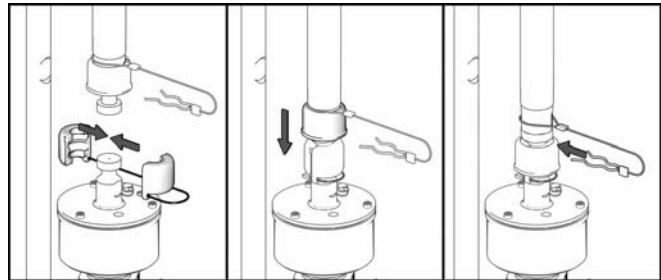

FIG. 19

4. Pumps with 100cc, 200cc, and 250cc displacement pumps only: Install coupling (7), and slide coupling cover (8) down. Install clip (9).



ti10509a

FIG. 20

5. Pumps with 60cc and 500cc displacement pumps only: Reinstall coupling nut and coupling covers on displacement rod. Slide coupling nut up and tighten using a torque wrench with a claw foot; see the following table for torque values.

Displacement Pump	Torque
60cc	75-80 ft-lbs (102-108 N•m)
500cc	230-250 ft-lbs (312-340 N•m)

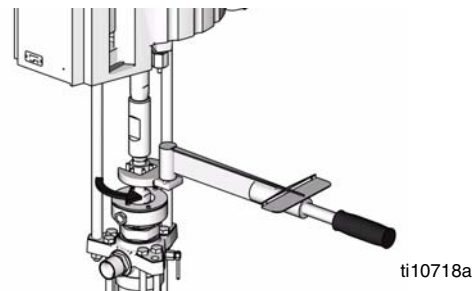

ti10718a

FIG. 21

6. Reconnect all hoses. Reconnect ground wire and reed switch cable (units with remote DataTrak) if they were disconnected. Fill wet cup (R) 1/3 full of Graco Throat Seal Liquid or a compatible solvent.
7. Attach platen to displacement pump. Refer to the Supply Units Repair-Parts manual for instructions
8. Turn on the air power supply. Run the pump slowly to ensure that it is operating properly.
9. Allow 2 hours for the thread sealant to cure before returning the pump to service.

Parts

Pump Package	Parts List Page
Pump Packages with L060xx Displacement Pumps	pg 24
Pump Packages with L100xx Displacement Pumps	pg 26
Pump Packages with L200xx Displacement Pumps	pg 27
Pump Packages with L250xx Displacement Pumps	pg 28
Pump Packages with L500xx Displacement Pumps	pg 29

NXT200, NXT400, NXT700, NXT1200, and NXT1800 Air Motors

Model P20LCM Shown

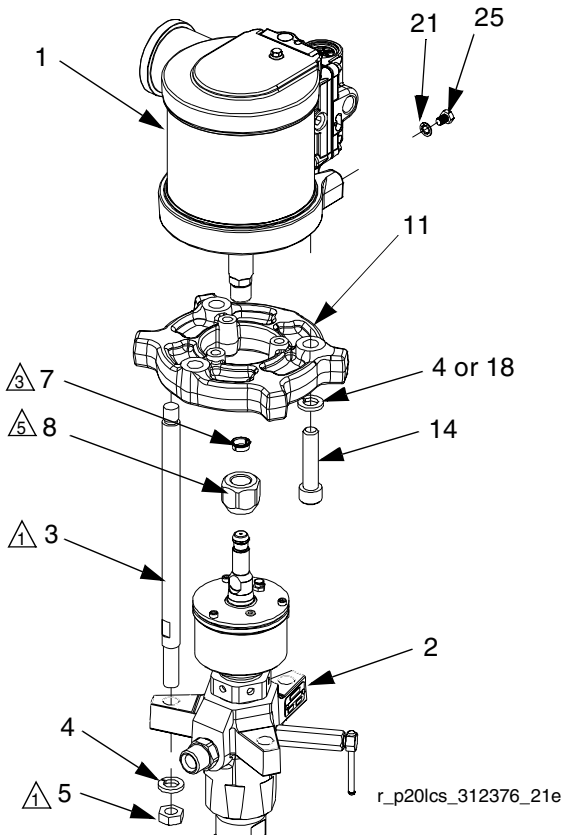

Motor Adapter 15M675

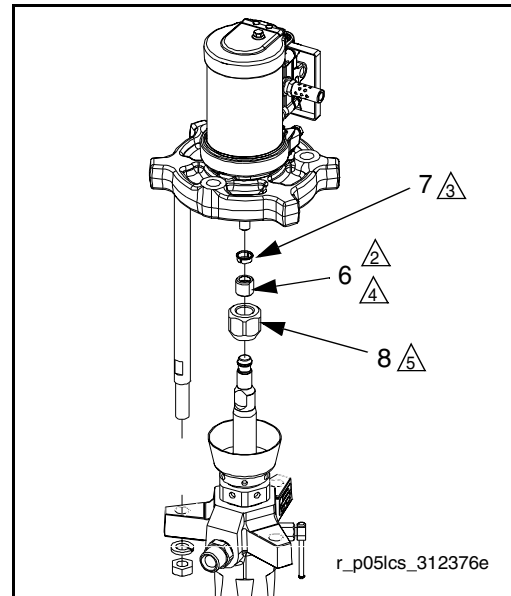

Reed Switch Assembly

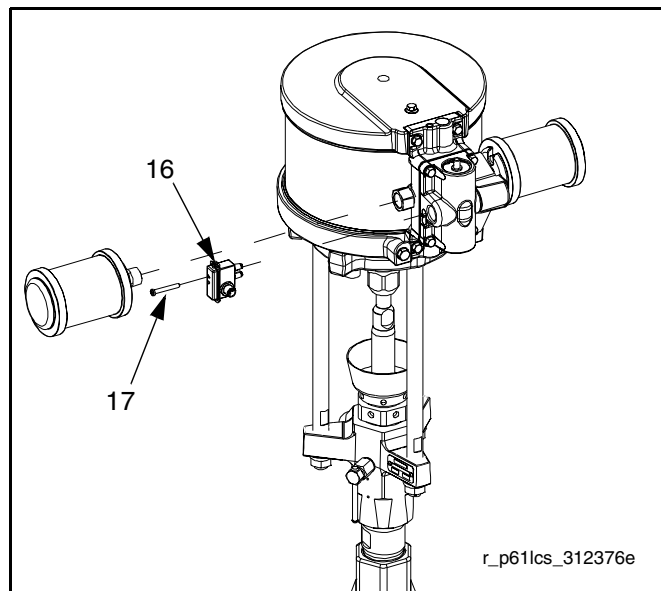

Key

- Torque to 50-60 ft-lb (68-81 N•m)
- Torque to 124-155 ft-lb (196-210 N•m)
- Apply lubricant
- Apply sealant
- Torque to 75-80 ft-lb (102-108 N•m)

Pump Packages Continued

NXT2200, NXT3400, and NXT6500 Air Motors

Model P40RCM Shown

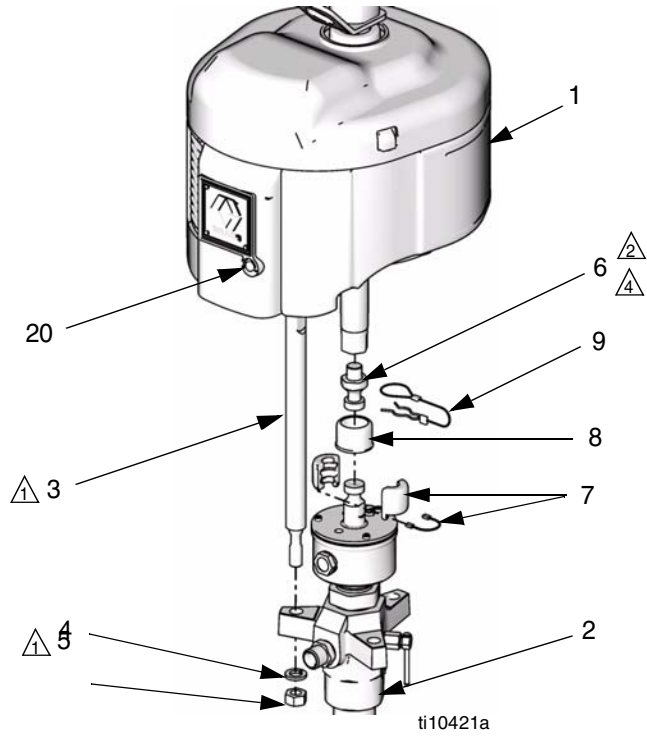

Model P39LCS Shown

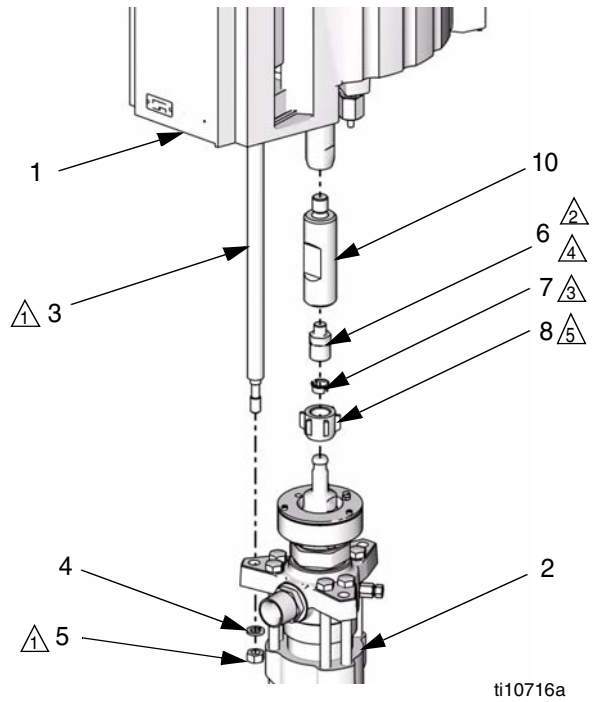

Adapter Bracket 15M222

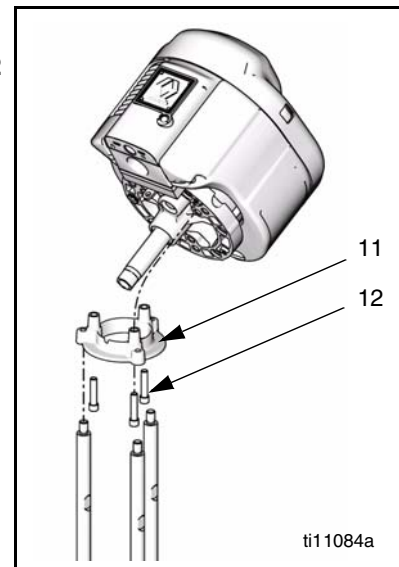

Key

- ① Torque to 50-60 ft-lb (68-81 N•m)
- ② Torque to 124-155 ft-lb (196-210 N•m)
- ③ Apply lubricant
- ④ Apply sealant
- ⑤ Torque to 230-250 ft-lbs (312-340 N•m)

Pump Packages with L060xx Displacement Pumps

Common Parts

Ref.	Part	Description	Qty.	Ref.	Part	Description	Qty.
3	171313	ROD, tie	3	8	15T311	COUPLER, cover	1
5	100681	NUT, jam, hex	3	11	257663	ADAPTER, rod	
7	184128	COUPLING, assy.	1	21	100186	WASHER, lock, internal tooth	1
				23	112887	WRENCH, spanner; not shown	1
				25	15V909	SCREW, ground	1

Varying Parts

Pump Package	Reference Number and Description							18
	1	2	4	6	14	16	17	
	Motor (see 312796)	Displacement Pump (see 312375)	Washer, lock (Qty)	Adapter, motor	Screw	Reed Assy. Switch	Screw	
P05LCS	M02LN0	L060CS	100128 (3)	15M675	112339	NA	NA	100133
P05LCM	M02LN0	L060CM						
P05LSS	M02LN0	L060SS						
P05LSM	M02LN0	L060SM						
P11LCS	M04LN0	L060CS	100128 (3)	15M675	112339	NA	NA	100133
P11LCM	M04LN0	L060CM						
P11LSS	M04LN0	L060SS						
P11LSM	M04LN0	L060SM						
P11RCS	M04LN0	L060CS				24A032	15V719	
P11RCM	M04LN0	L060CM						
P11RSS	M04LN0	L060SS						
P11RSM	M04LN0	L060SM						
P11SCS	M04LH0	L060CS						
P11SCM	M04LH0	L060CM						
P11SSS	M04LH0	L060SS						
P11SSM	M04LH0	L060SM						
P20LCS	M07LN0	L060CS	100128 (6)	NA	121843	NA	NA	NA
P20LCM	M07LN0	L060CM						
P20LSS	M07LN0	L060SS						
P20LSM	M07LN0	L060SM						
P20RCS	M07LN0	L060CS						
P20RCM	M07LN0	L060CM						
P20RSS	M07LN0	L060SS						
P20RSM	M07LN0	L060SM						
Qty.	1	1	3 or 6	1	3	1	1	3

Varying Parts Continued

Pump Package	Reference Number and Description							
	1	2	4	6	14	16	17	18
	Motor (see 311238)	Displacement Pump (see 312375)	Washer, lock (Qty)	Adapter, motor	Screw	Reed Assy. Switch	Screw	Washer, lock
P20SCS	M07LH0	L060CS	100128 (6)	NA	121843	24A032	15V719	NA
P20SCM	M07LH0	L060CM						
P20SSS	M07LH0	L060SS						
P20SSM	M07LH0	L060SM						
P38LCS	M12LN0	L060CS	100128 (6)	NA	121843	NA	NA	NA
P38LCM	M12LN0	L060CM						
P38LSS	M12LN0	L060SS						
P38LSM	M12LN0	L060SM						
P38RCS	M12LN0	L060CS						
P38RCM	M12LN0	L060CM						
P38RSS	M12LN0	L060SS						
P38RSM	M12LN0	L060SM						
P38SCS	M12LH0	L060CS						
P38SCM	M12LH0	L060CM						
P38SSS	M12LH0	L060SS						
P38SSM	M12LH0	L060SM						
P61LCS	M18LN0	L060CS	100128 (6)	NA	121843	NA	NA	NA
P61LCM	M18LN0	L060CM						
P61LSS	M18LN0	L060SS						
P61LSM	M18LN0	L060SM						
P61RCS	M18LN0	L060CS						
P61RCM	M18LN0	L060CM						
P61RSS	M18LN0	L060SS						
P61RSM	M18LN0	L060SM						
P61SCS	M18LH0	L060CS						
P61SCM	M18LH0	L060CM						
P61SSS	M18LH0	L060SS						
P61SSM	M18LH0	L060SM						
Qty.	1	1	3 or 6	1	3	1	1	3

Pump Packages with L100xx Displacement Pumps

Common Parts

Ref.	Part	Description	Qty.	Ref.	Part	Description	Qty.
3	257360	ROD, tie	3	6	15H392	ROD, adapter	1
4	108098	WASHER, lock, spring	3	7	244819	COUPLING, assy.	1
5	106166	NUT, mach, hex	3	8	197340	COUPLER, cover	1
				9	244820	CLIP, hairpin with lanyard	1
				20	120588	PLUG, pipe, round	1

Varying Parts

Pump Package	Reference Number and Description	
	1	2
	Motor (see 311238)	Displacement Pump (see 312375)
P40LCS	N22LN0	L100CS
P40LCM	N22LN0	L100CM
P40LSS	N22LN0	L100SS
P40LSM	N22LN0	L100SM
P40SSM	N22LH0	L100SM
P40SSS	N22LH0	L100SS
P40SCS	N22LH0	L100CS
P40RCS	N22LR0	L100CS
P40RCM	N22LR0	L100CM
P40RSM	N22LR0	L100SM
P40RSS	N22LR0	L100SS
P63LCS	N34LN0	L100CS
P63LCM	N34LN0	L100CM
P63LSM	N34LN0	L100SM
P63LSS	N34LN0	L100SS
P63RCS	N34LR0	L100CS
P63RCM	N34LR0	L100CM
P63RSM	N34LR0	L100SM
P63RSS	N34LR0	L100SS
P63SSM	N34LH0	L100SM
P63SSS	N34LH0	L100SS
P63MCS	N34LT0	L100CS
Qty.	1	1

Pump Packages with L200xx Displacement Pumps

Common Parts

Ref.	Part	Description	Qty.
4	108098	WASHER, lock, spring	3
5	106166	NUT, mach, hex	3
20	120588	PLUG, pipe, round	1

Varying Parts

Pump Package	Reference Number and Description								
	1	2	3	6	7	8	9	11	12
	Motor (see 311238)	Displacement Pump (see 312375)	Rod, tie	Adapter, rod	Coupling, assy.	Cover, coupler	Clip, hairpin w/ lanyard	Bracket, adapter	Screw, cap head
P23LCS	N22LN0	L200CS	15M619	15H392	244819	197340	244820	15M222	C19792
P23LCM	N22LN0	L200CM							
P23LSS	N22LN0	L200SS							
P23LSM	N22LN0	L200SM							
P23RCS	N22LR0	L200CS							
P23RCM	N22LR0	L200CM							
P23RSS	N22LR0	L200SS							
P23RSM	N22LR0	L200SM							
P36LCS	N34LN0	L200CS	257360	15H392	244819	197340	244820	N/A	N/A
P36LCM	N34LN0	L200CM							
P36LSS	N34LN0	L200SS							
P36LSM	N34LN0	L200SM							
P36RCS	N34LR0	L200CS							
P36RCM	N34LR0	L200CM							
P36RSS	N34LR0	L200SS							
P36RSM	N34LR0	L200SM							
P68LCS	N65LN0	L200CS	257360	15H392	244819	197340	244820	N/A	N/A
P68LCM	N65LN0	L200CM							
P68LSS	N65LN0	L200SS							
P68LSM	N65LN0	L200SM							
P68RCS	N65LR0	L200CS							
P68RCM	N65LR0	L200CM							
P68RSS	N65LR0	L200SS							
P68RSM	N65LR0	L200SM							
P68MCS	N65LT0	L200CS							
P68SCS	N65LH0	L200CS							
Qty.	1	1	3	1	1	1	1	1	3

Pump Packages with L250xx Displacement Pumps

Common Parts

Ref.	Part	Description	Qty.
4	108098	WASHER, lock, spring	3
5	106166	NUT, mach, hex	3
20	120588	PLUG, pipe, round (NXT3400 and NXT6500 motors only)	1

Varying Parts

Pump Package	Reference Number and Description							
	1	2	3	6	7	8	9	10
	Motor (see 311238 or 308213)	Displace- ment Pump (see 312375)	Rod, tie	Adapter, rod	Coupling, assy.	Cover, coupler	Clip, hairpin w/ lanyard	Coupler (Premier only)
P29LCS	N34LN0	L250CS	257360	15H392	244819	197340	244820	N/A
P29LCM	N34LN0	L250CM						
P29LSS	N34LN0	L250SS						
P29LSM	N34LN0	L250SM						
P29RCS	N34LR0	L250CS						
P29RCM	N34LR0	L250CM						
P29RSS	N34LR0	L250SS						
P29RSM	N34LR0	L250SM						
P29MCS	N34LT0	L250CS						
P55LCS	N65LN0	L250CS	257360	15H392	244819	197340	244820	N/A
P55LCM	N65LN0	L250CM						
P55LSS	N65LN0	L250SS						
P55LSM	N65LN0	L250SM						
P55RCS	N65LR0	L250CS						
P55RCM	N65LR0	L250CM						
P55RSS	N65LR0	L250SS						
P55RSM	N65LR0	L250SM						
P55MCS	N65LT0	L250CS						
P82LCS	222800	L250CS	184381	15H392	244819	197340	244820	15M631
P82LCM	222800	L250CM						
P82LSS	222800	L250SS						
P82LSM	222800	L250SM						
Qty.	1	1	3	1	1	1	1	1

Pump Packages with L500xx Displacement Pumps

Common Parts

Ref.	Part	Description	Qty.
4	108098	WASHER, lock, spring	3
5	106166	NUT, mach, hex	3
20	120588	PLUG, pipe, round (NXT3400 and NXT6500 motors only)	1

Varying Parts

Pump Package	Reference Number and Description							
	1	2	3	6	7	8	9	10
	Motor (see 311238 or 308213)	Displace- ment Pump (see 312375)	Rod, tie	Adapter, rod	Collar, coupling	Nut, coupling	Clip, hairpin w/ lanyard	Coupler (Premier only)
P14LCS	N34LN0	L500CS	257360	15H370	184129	186925	N/A	N/A
P14LCM	N34LN0	L500CM						
P14LSS	N34LN0	L500SS						
P14LSM	N34LN0	L500SM						
P14RCS	N34LR0	L500CS						
P14RCM	N34LR0	L500CM						
P14RSS	N34LR0	L500SS						
P14RSM	N34LR0	L500SM						
P14MCS	N34LT0	L500CS						
P26LCS	N65LN0	L500CS	257360	15H370	184129	186925	N/A	N/A
P26LCM	N65LN0	L500CM						
P26LSS	N65LN0	L500SS						
P26LSM	N65LN0	L500SM						
P26RCS	N65LR0	L500CS						
P26RCM	N65LR0	L500CM						
P26RSS	N65LR0	L500SS						
P26RSM	N65LR0	L500SM						
P26MCS	N65LT0	L500CS						
P26SSS	N65LH0	L500SS						
P26SCS	N65LH0	L500CS						
P39LCS	222800	L500CS	184381	15H370	184129	186925	N/A	15M631
P39LCM	222800	L500CM						
P39LSS	222800	L500SS						
P39LSM	222800	L500SM						
Qty.	1	1	3	1	2	1	1	1

Dimensions

Pump Packages with NXT 2200, NXT 3400, and NXT 6500 Air Motors

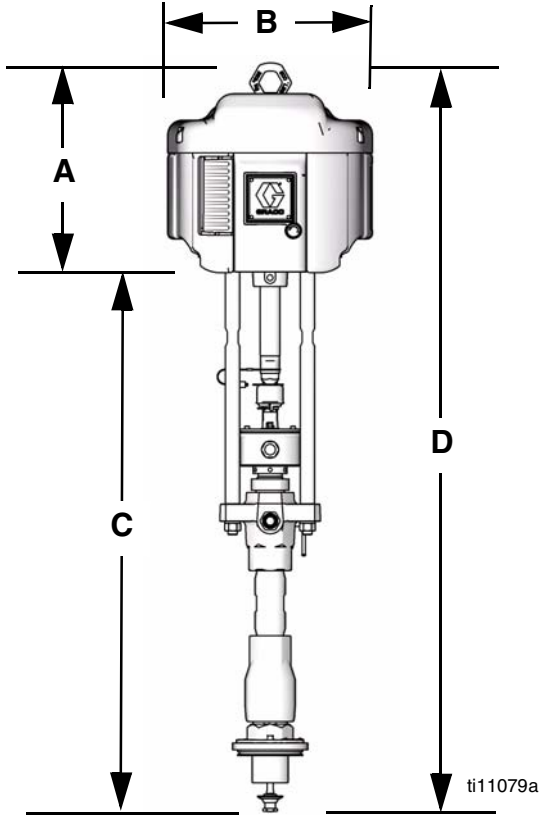

Pump Packages with Premier Air Motors

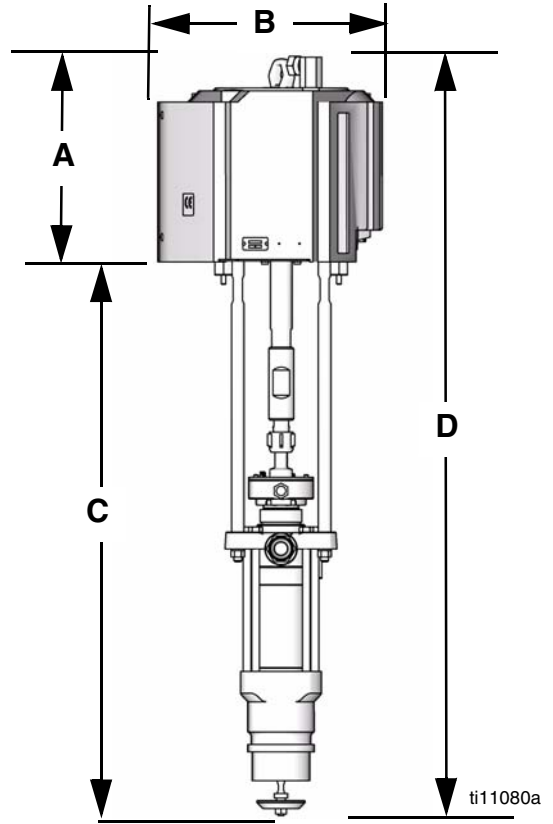

Pump Packages with NXT 200, NXT 400, NXT 700, NXT 1200, and NXT 1800 Air Motors

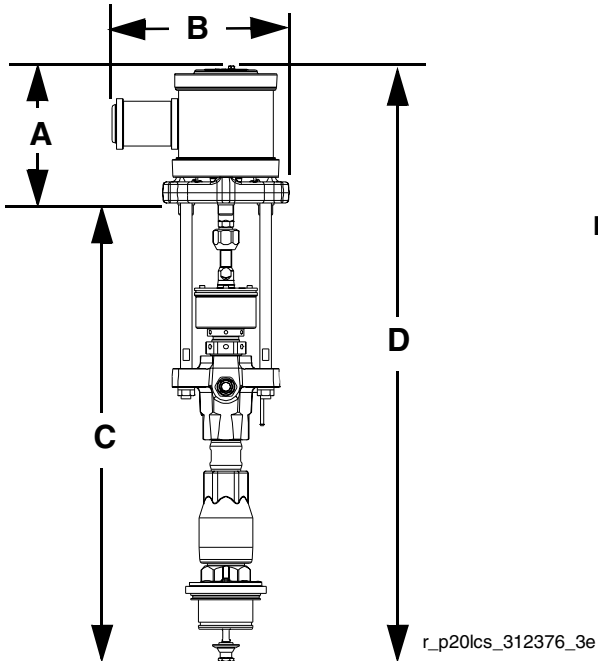

Note: See dimensions in table on next page.

Table 1: Pump Package Dimensions

Pressure Ratio (xx:1)	Motor	Displacement Pump Volume (cc per cycle)	A in. (mm)	B in. (mm)	C in. (mm)	D in. (mm)	Weight lbs (kg)
05	NXT200	60	8.12 (206.2)	8.11 (205.9)	29.54 (750.3)	37.66 (956.6)	56 (25)
11	NXT400	60	8.28 (210.3)	8.11 (205.9)	29.54 (750.3)	37.82 (960.6)	58 (26)
14	NXT3400	500	13.70 (348.0)	14.00 (355.6)	39.13 (993.9)	52.83 (1,341.9)	152 (69)
20	NXT700	60	8.44 (214.4)	8.11 (205.9)	29.54 (750.3)	37.98 (964.7)	63 (29)
23	NXT2200	200	16.35 (415.3)	12.40 (315.0)	36.27 (921.3)	52.62 (1,336.5)	130 (59)
26	NXT6500	500	13.78 (350.0)	16.20 (411.5)	39.13 (993.9)	52.91 (1,343.9)	169 (77)
29	NXT3400	250	13.70 (348.0)	14.00 (355.6)	39.20 (995.7)	52.90 (1,343.7)	128 (58)
36	NXT3400	200	13.70 (348.0)	14.00 (355.6)	39.27 (997.5)	52.97 (1,345.4)	128 (58)
38	NXT1200	60	8.60 (218.4)	12.30 (312.4)	29.54 (750.3)	38.14 (968.8)	69 (31)
39	Premier	500	15.76 (400.3)	17.90 (454.7)	44.30 (1,125.2)	60.06 (1,525.5)	157 (71)
40	NXT2200	100	13.45 (341.6)	12.40 (315.0)	38.18 (969.8)	51.63 (1,311.4)	97 (44)
55	NXT6500	250	13.78 (350.0)	16.20 (411.5)	39.20 (995.7)	52.98 (1,345.7)	145 (66)
61	NXT1800	60	8.76 (222.5)	14.79 (375.7)	29.54 (750.3)	38.30 (972.8)	74 (34)
63	NXT3400	100	13.70 (348.0)	14.00 (355.6)	38.18 (969.8)	51.88 (1,317.8)	101 (46)
68	NXT6500	200	13.78 (350.0)	16.20 (411.5)	39.27 (997.5)	53.05 (1,347.5)	145 (66)
82	Premier	250	15.76 (400.3)	17.90 (454.7)	44.37 (1,127.0)	60.13 (1,527.3)	132 (60)

Technical Data

Air motor piston diameter	Refer to separate air motor manual.
Stroke length	100cc, 200cc, 250cc, 500cc: 4.75 in. (120.65 mm) 60cc: 2.5 in. (63.5 mm)
Displacement pump effective area	Refer to Check-Mate Displacement Pump manual 312375.
Maximum fluid operating temperature	180° F (82.3° C)
Air Inlet Size	NXT200 and NXT400 air motors: 1/4 npt (f) NXT700, NXT1200, and NXT1800 air motors: 1/2 npt (f) NXT2200, NXT3400, and NXT6500 air motors: 3/4 npt (f) Premier air motor: 1.0 in. npsm
Fluid outlet size	Refer to Check-Mate Displacement Pump manual 312375.
Displacement Pump weight	Refer to Check-Mate Displacement Pump manual 312375.
Maximum pump speed (Do not exceed maximum recommended speed of fluid pump, to prevent premature pump wear)	NXT air motor: 60 cpm Premier air motor: 50 cpm
Wetted parts	Refer to Check-Mate Displacement Pump manual 312375.



Refer to separate motor manual for sound data and mounting hole layout.

Maximum Fluid Working Pressure and Flow Rate at Full Air Pressure (100 psi)

Ratio	Maximum Air Inlet Pressure psi (MPa, bar)	Maximum Fluid Working Pressure psi (MPa, bar)	Motor	Displacement Pump (cc per cycle)	Flow Rate gpm (lpm)	
					30 cpm	60 cpm
05	100 (0.7, 7.0)	500 (3.4, 34)	NXT200	60	0.5 (2.0)	0.9 (3.4)
11	100 (0.7, 7.0)	1100 (7.6, 76)	NXT400	60	0.5 (2.0)	0.9 (3.4)
14	100 (0.7, 7.0)	1400 (9.8, 98)	NXT3400	500	4.0 (15.0)	7.8 (30.0)
20	100 (0.7, 7.0)	2000 (13.8, 138)	NXT700	60	0.5 (2.0)	0.9 (3.4)
23	100 (0.7, 7.0)	2300 (16.1, 161)	NXT2200	200	1.6 (6.0)	3.2 (12.0)
26	100 (0.7, 7.0)	2600 (18.2, 182)	NXT6500	500	4.0 (15.0)	7.8 (30.0)
29	100 (0.7, 7.0)	2900 (20.3, 203)	NXT3400	250	2.0 (7.5)	4.0 (15.0)
36	100 (0.7, 7.0)	3600 (25.2, 252)	NXT3400	200	1.6 (6.0)	3.2 (12.0)
38	100 (0.7, 7.0)	3800 (26.2, 262)	NXT1200	60	0.5 (2.0)	0.9 (3.4)
39	100 (0.7, 7.0)	3900 (27.3, 273)	Premier	500	4.0 (15.0)	7.8 (30.0)
40	100 (0.7, 7.0)	4000 (28.0, 280)	NXT2200	100	0.8 (3.0)	1.6 (6.0)
55	100 (0.7, 7.0)	5500 (38.5, 385)	NXT6500	250	2.0 (7.5)	4.0 (15.0)
61	100 (0.7, 7.0)	6100 (42.1, 421)	NXT1800	60	0.5 (2.0)	0.9 (3.4)
63	100 (0.7, 7.0)	6300 (44.1, 441)	NXT3400	100	0.8 (3.0)	1.6 (6.0)
68	91 (0.64, 6.4)	6200 (43.4, 434)	NXT6500	200	1.6 (6.0)	3.2 (12.0)
82	76 (0.53, 5.3)	6200 (43.4, 434)	Premier	250	2.0 (7.5)	4.0 (15.0)

Performance Charts

Calculate Fluid Outlet Pressure

To calculate fluid outlet pressure (psi/MPa/bar) at a specific fluid flow (gpm/lpm) and operating air pressure (psi/MPa/bar), use the following instructions and pump data charts.

1. Locate desired flow along bottom of chart.
2. Follow vertical line up to intersection with selected fluid outlet pressure curve. Follow left to scale to read fluid outlet pressure.

Key: Air Pressure

- A 100 psi (0.7 MPa, 7 bar)
- B 70 psi (0.5 MPa, 5.0 bar)
- C 40 psi (0.3 MPa, 2.8 bar)
- D 90 psi (0.63 MPa, 6.3 bar)

Note:

Use the following key to determine which fluid is presented in the corresponding performance charts.

Key: Test Fluid

- E No. 10 weight oil
- F 100,000 centipoise sealant test fluid
- G 4,000,000 centipoise silicon test fluid
- H 4,000,000 centipoise weldable rubber base sealer
- J 8,000,000 centipoise pseudoplastic (expandable plastisal sealer (500,000 centipoise at flow conditions))

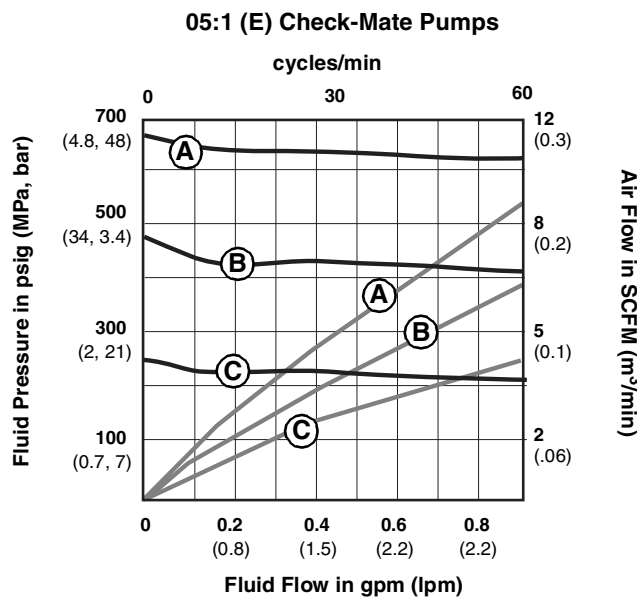

Calculate Pump Air Flow/Consumption

To calculate pump air flow/consumption (scfm or m³/min) at a specific fluid flow (gpm/lpm) and air pressure (psi/MPa/bar), use the following instructions and pump data charts.

1. Locate desired flow along bottom of chart.
2. Follow vertical line up to intersection with selected air flow/consumption curve. Follow right to scale to read air flow/consumption.

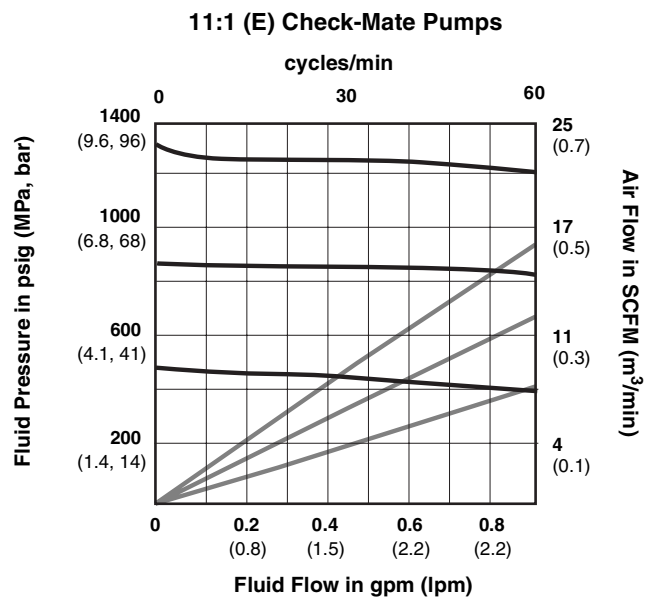

14:1 (E) Check-Mate Pumps
cycles/min

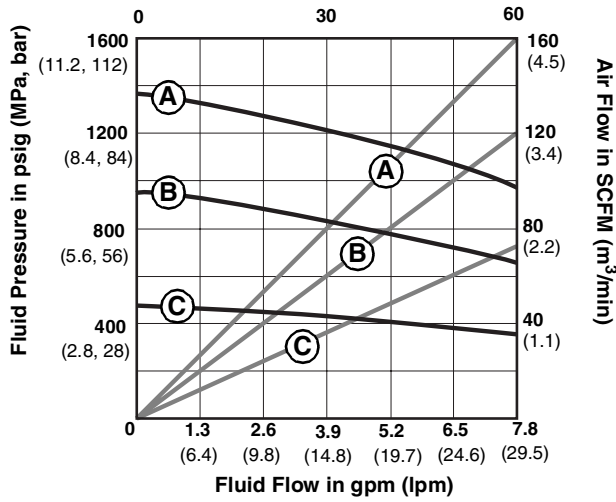

14:1 (J) Check-Mate Pumps
cycles/min

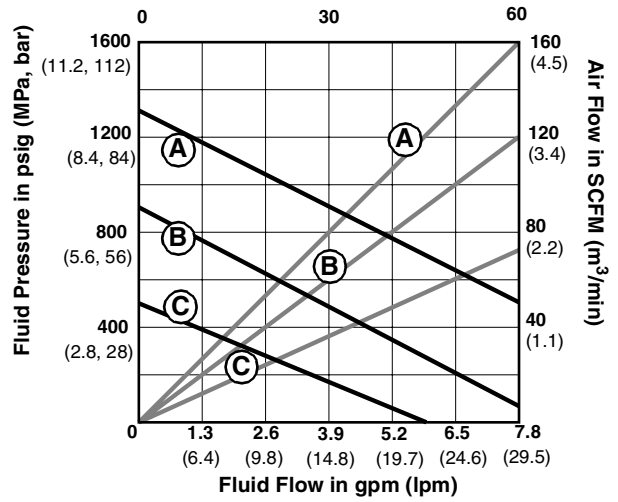

20:1 (E) Check-Mate Pumps
cycles/min

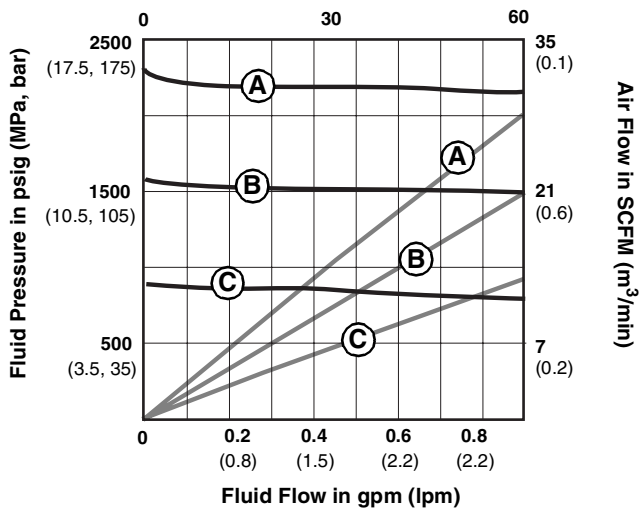

23:1 (J) Check-Mate Pumps
cycles/min

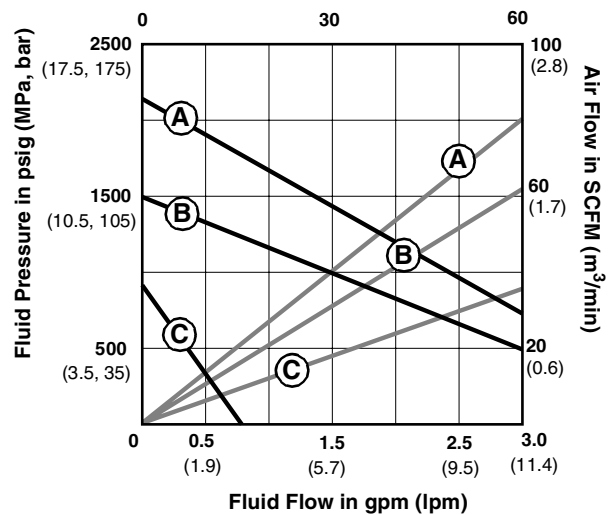
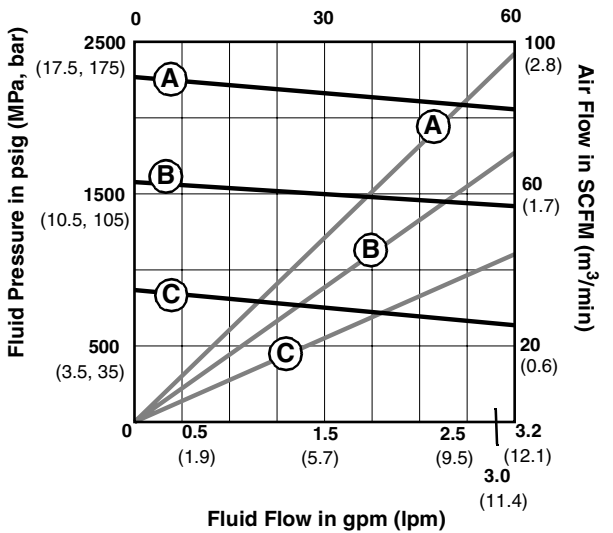

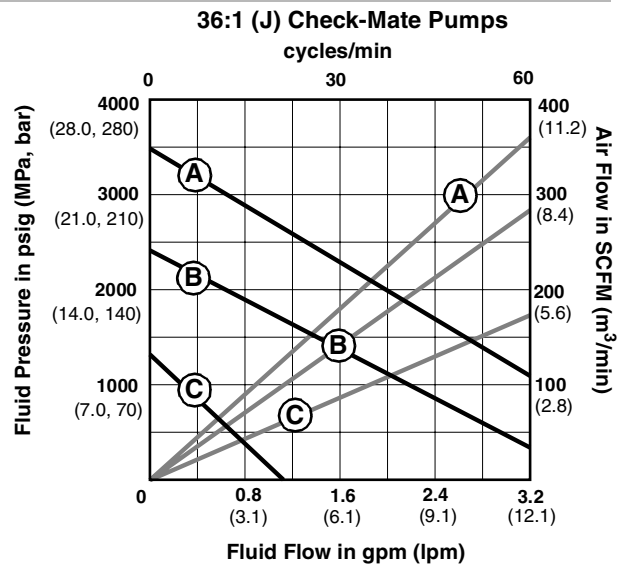
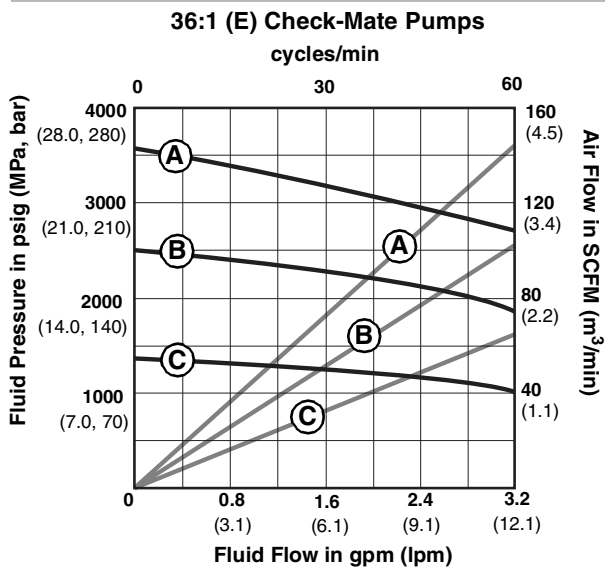
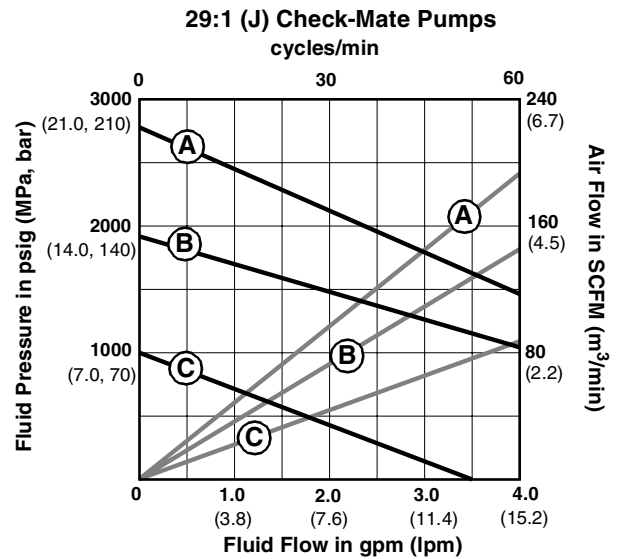
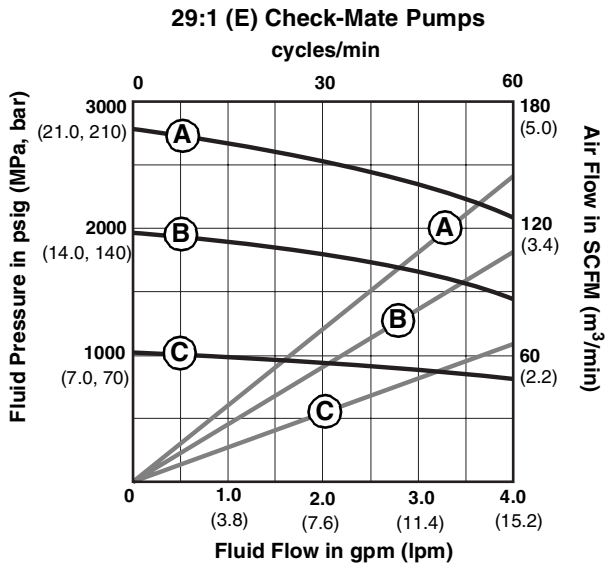
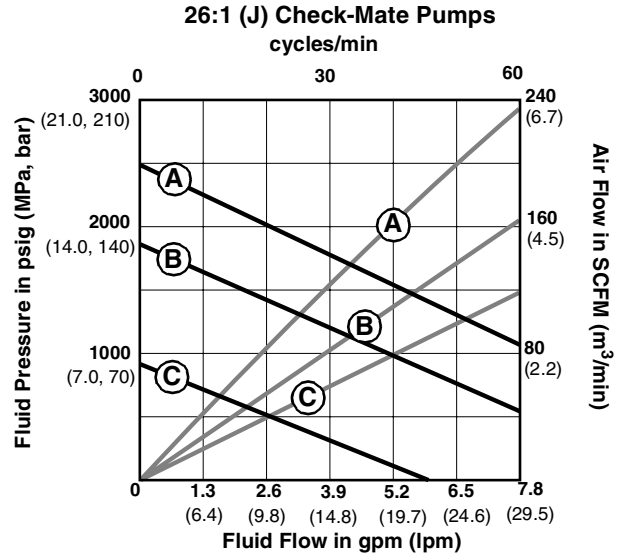
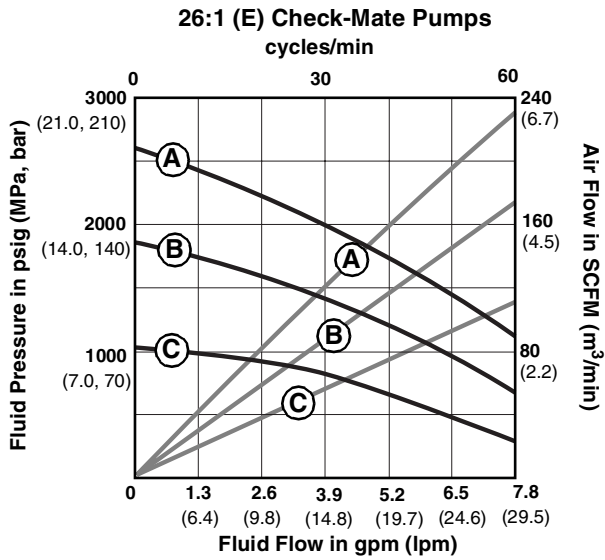

38:1 (E) Check-Mate Pumps
cycles/min

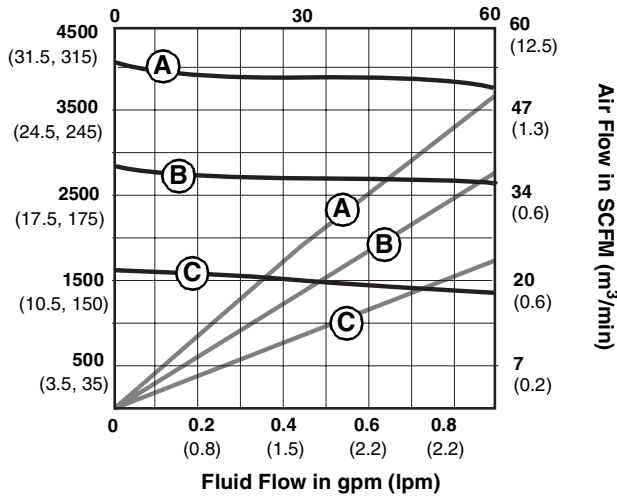

39:1 (G) Check-Mate Pumps
cycles/min

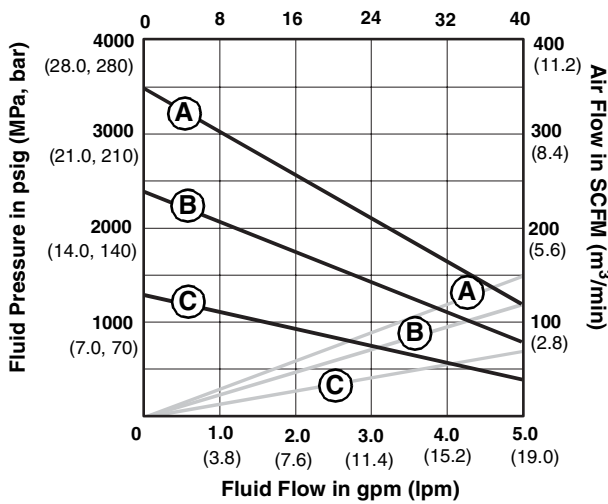

40:1 (E) Check-Mate Pumps
cycles/min

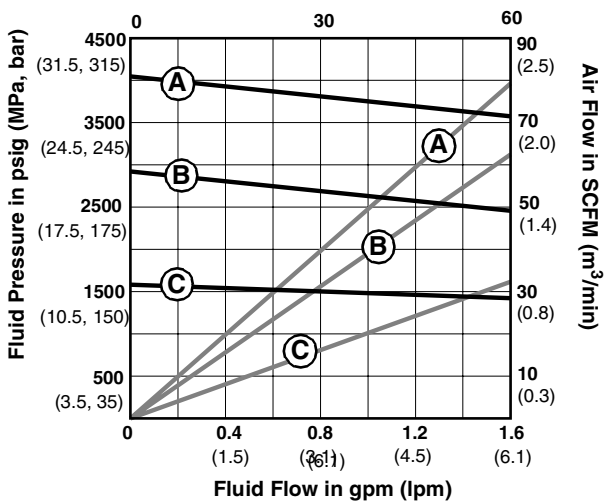

40:1 (J) Check-Mate Pumps
cycles/min

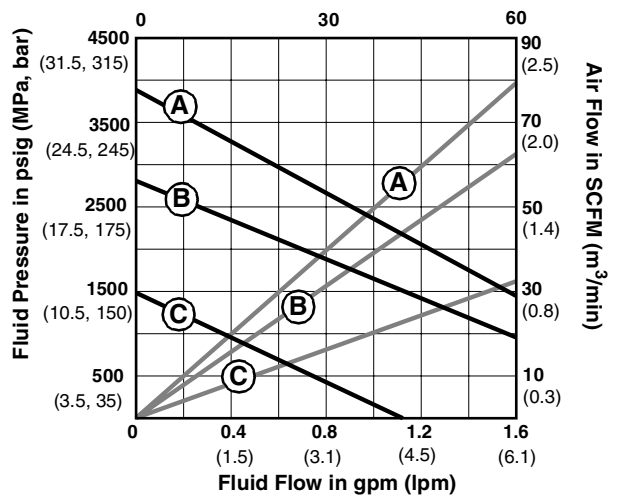

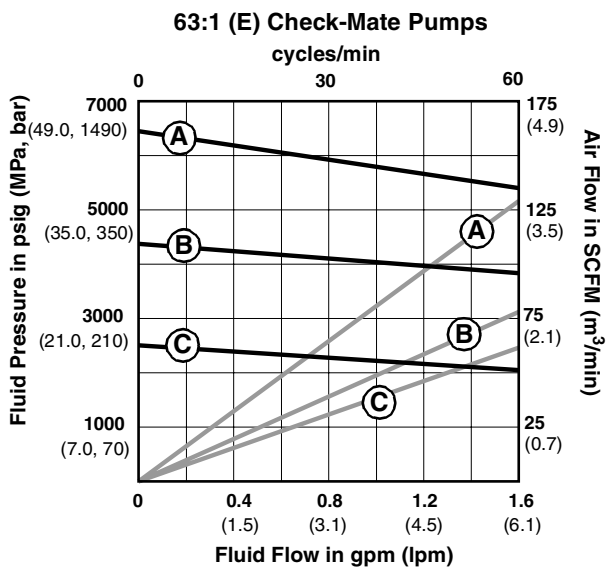
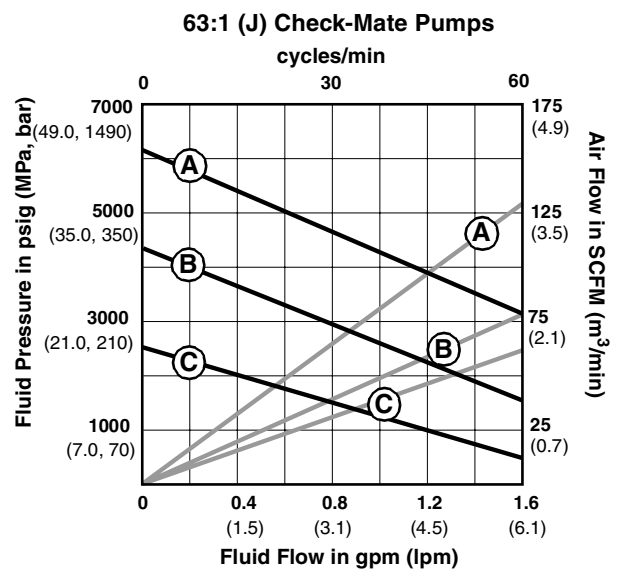
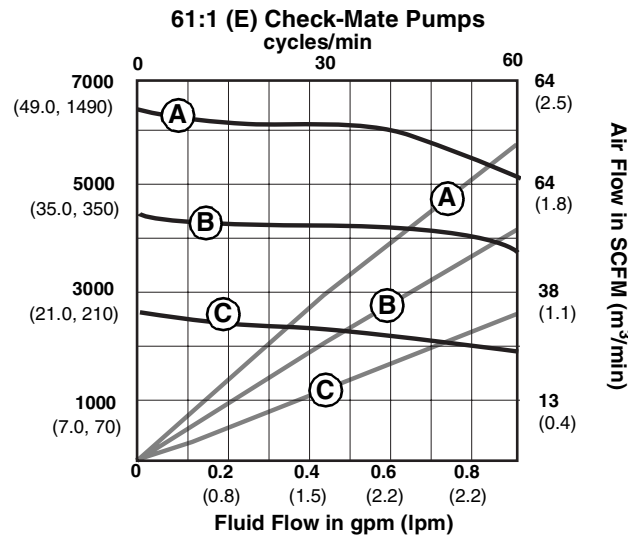
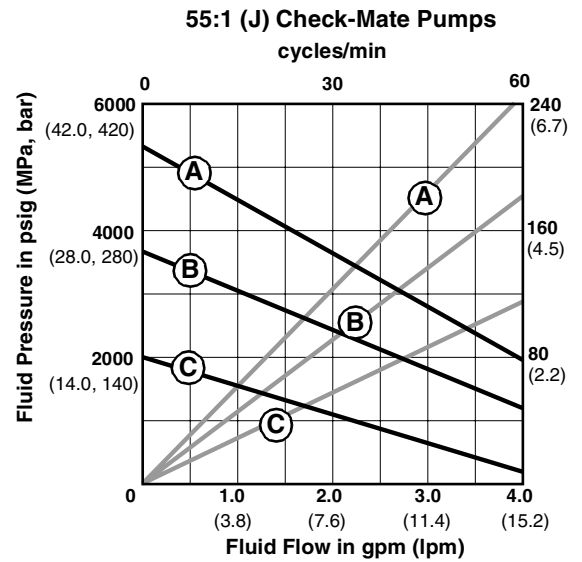
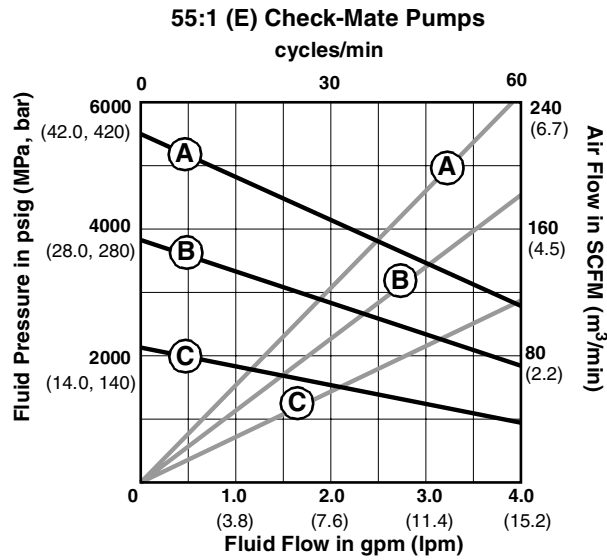

68:1 (E) Check-Mate Pumps
cycles/min

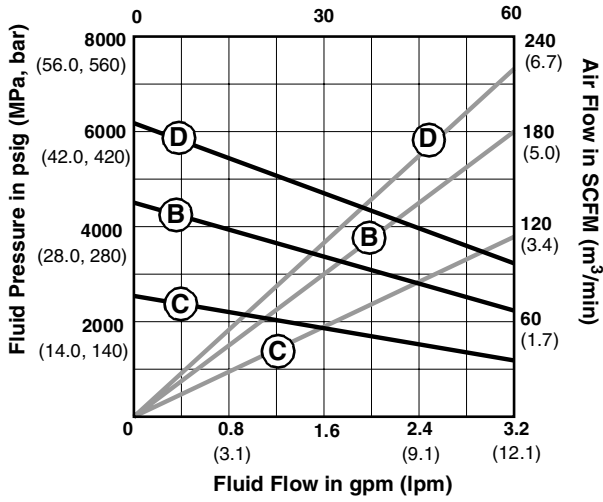

68:1 (J) Check-Mate Pumps
cycles/min

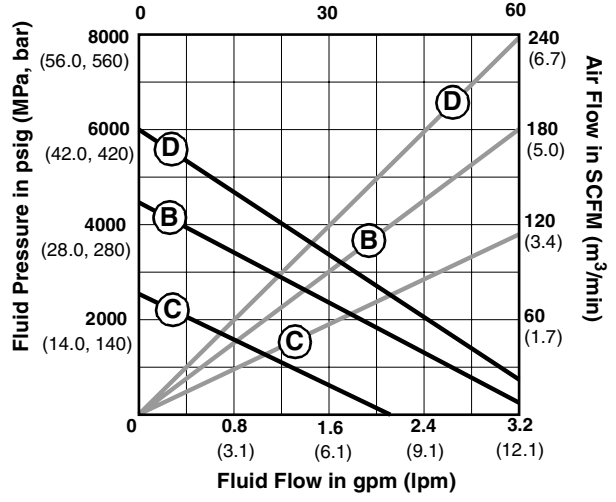

82:1 (E) Check-Mate Pumps
cycles/min

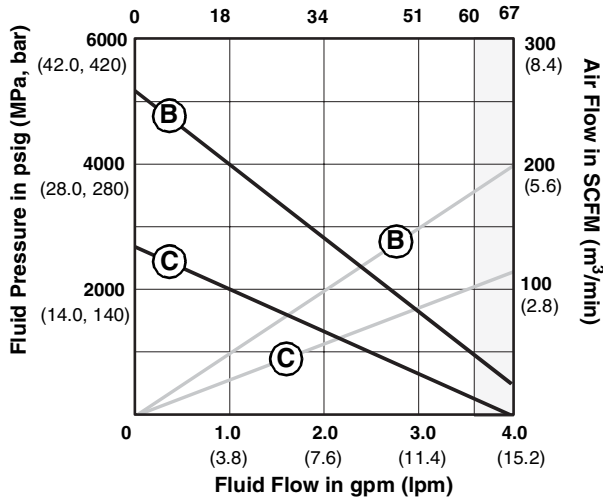

82:1 (H) Check-Mate Pumps
cycles/min

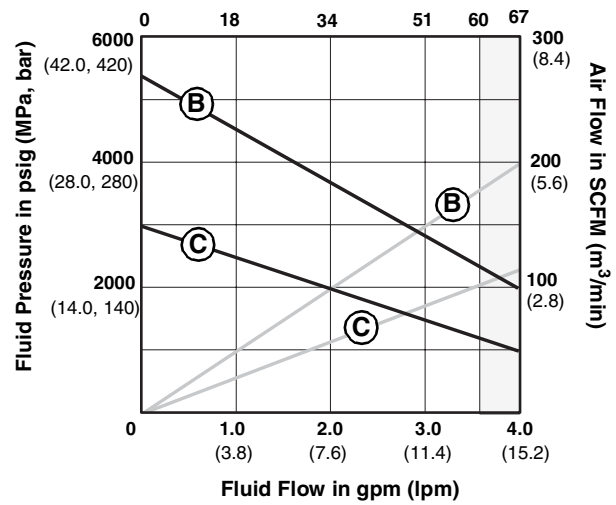

Graco Standard Warranty

Graco warrants all equipment referenced in this document which is manufactured by Graco and bearing its name to be free from defects in material and workmanship on the date of sale to the original purchaser for use. With the exception of any special, extended, or limited warranty published by Graco, Graco will, for a period of twelve months from the date of sale, repair or replace any part of the equipment determined by Graco to be defective. This warranty applies only when the equipment is installed, operated and maintained in accordance with Graco's written recommendations.

This warranty does not cover, and Graco shall not be liable for general wear and tear, or any malfunction, damage or wear caused by faulty installation, misapplication, abrasion, corrosion, inadequate or improper maintenance, negligence, accident, tampering, or substitution of non-Graco component parts. Nor shall Graco be liable for malfunction, damage or wear caused by the incompatibility of Graco equipment with structures, accessories, equipment or materials not supplied by Graco, or the improper design, manufacture, installation, operation or maintenance of structures, accessories, equipment or materials not supplied by Graco.

This warranty is conditioned upon the prepaid return of the equipment claimed to be defective to an authorized Graco distributor for verification of the claimed defect. If the claimed defect is verified, Graco will repair or replace free of charge any defective parts. The equipment will be returned to the original purchaser transportation prepaid. If inspection of the equipment does not disclose any defect in material or workmanship, repairs will be made at a reasonable charge, which charges may include the costs of parts, labor, and transportation.

THIS WARRANTY IS EXCLUSIVE, AND IS IN LIEU OF ANY OTHER WARRANTIES, EXPRESS OR IMPLIED, INCLUDING BUT NOT LIMITED TO WARRANTY OF MERCHANTABILITY OR WARRANTY OF FITNESS FOR A PARTICULAR PURPOSE.

Graco's sole obligation and buyer's sole remedy for any breach of warranty shall be as set forth above. The buyer agrees that no other remedy (including, but not limited to, incidental or consequential damages for lost profits, lost sales, injury to person or property, or any other incidental or consequential loss) shall be available. Any action for breach of warranty must be brought within two (2) years of the date of sale.

GRACO MAKES NO WARRANTY, AND DISCLAIMS ALL IMPLIED WARRANTIES OF MERCHANTABILITY AND FITNESS FOR A PARTICULAR PURPOSE, IN CONNECTION WITH ACCESSORIES, EQUIPMENT, MATERIALS OR COMPONENTS SOLD BUT NOT MANUFACTURED BY GRACO. These items sold, but not manufactured by Graco (such as electric motors, switches, hose, etc.), are subject to the warranty, if any, of their manufacturer. Graco will provide purchaser with reasonable assistance in making any claim for breach of these warranties.

In no event will Graco be liable for indirect, incidental, special or consequential damages resulting from Graco supplying equipment hereunder, or the furnishing, performance, or use of any products or other goods sold hereto, whether due to a breach of contract, breach of warranty, the negligence of Graco, or otherwise.

FOR GRACO CANADA CUSTOMERS

The Parties acknowledge that they have required that the present document, as well as all documents, notices and legal proceedings entered into, given or instituted pursuant hereto or relating directly or indirectly hereto, be drawn up in English. Les parties reconnaissent avoir convenu que la rédaction du présente document sera en Anglais, ainsi que tous documents, avis et procédures judiciaires exécutés, donnés ou intentés, à la suite de ou en rapport, directement ou indirectement, avec les procédures concernées.

Graco Information

For the latest information about Graco products, visit www.graco.com.

TO PLACE AN ORDER, contact your Graco distributor or call to identify the nearest distributor.

Phone: 612-623-6921 **or Toll Free:** 1-800-328-0211 **Fax:** 612-378-3505

*All written and visual data contained in this document reflects the latest product information available at the time of publication.
Graco reserves the right to make changes at any time without notice.*

This manual contains English. MM 312376

Graco Headquarters: Minneapolis
International Offices: Belgium, China, Japan, Korea

GRACO INC. P.O. BOX 1441 MINNEAPOLIS, MN 55440-1441

Copyright 2007, Graco Inc. is registered to I.S. EN ISO 9001

www.graco.com

Revised 3/2009