

## Displacement Pump

310643N

*3300 psi (227 bar, 22.7 MPa) Maximum Working Pressure*

### **Model 248204, Series A**

Ultra® Max II and Ultimate Mx II 695 and 795  
ASM Zip-Spray™ 2700 Plus, 3100 Plus  
ASM AllPro Mach 8600 Plus and 11000 Plus  
ASM H2700 Plus

### **Model 255968, Series A**

ASM 3600G Plus

### **Model 248205, Series A**

Ultra Max II and Ultimate Mx II 1095 and 1595

### **Model 249059, Series A**

TexSpray™ Mark V

### **Model 249057, Series A**

TexSpray Mark V

### **Model 277069, Series A**

LineLazer™ IV 3900

### **Model 277070, Series A**

LineLazer™ IV 5900

### **Model 253056, Series A**

Mark IV



#### **Important Safety instructions**

Read all warnings and instructions in this manual.  
Save these instructions.

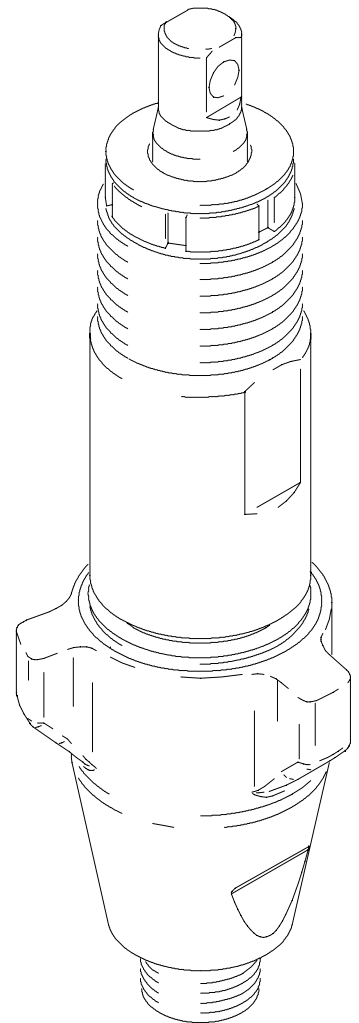

8016A

PROVEN QUALITY. LEADING TECHNOLOGY.

# Table of Contents

Warnings .....	2	Parts, Pump	
Service .....	3	248204, 255968 .....	16
Technical Data .....	15	248205, 249057, 249059, 277070 .....	17
		253056 .....	18
		Warranty .....	20

## WARNING



### EQUIPMENT MISUSE HAZARD

Misuse can cause death or serious injury.

- Do not exceed the maximum working pressure temperature rating of the lowest rated system component. See **Technical Data** in all equipment manuals.
- Use fluids and solvents compatible with equipment wetted parts. See **Technical Data** in all equipment manuals. Read manufacturer fluid and solvent warnings.
- Check equipment daily. Repair or replace worn or damaged parts immediately.
- Do not alter or modify equipment.
- Read all instruction manuals, tags, and labels before operating the equipment.
- Use equipment only for its intended purpose. Call your Graco distributor for information.
- Do not use 1,1,1-trichloroethane, methylene chloride, other halogenated hydrocarbon solvents or fluids containing such solvents in pressurized aluminum equipment. Such use could result in a chemical reaction, with the possibility of explosion.
- Comply with all applicable safety regulations.



### MOVING PARTS HAZARD

Moving parts can pinch or amputate your fingers.

- Keep clear of moving parts.
- Do not operate equipment with protective guards or covers removed.
- Pressurized equipment can start without warning. Before checking, moving or servicing equipment, follow the **Pressure Relief Procedure** on page 3. Disconnect power cord.



### SKIN INJECTION HAZARD

High-pressure fluid from gun, hose leaks or ruptured components will pierce skin. This may look like just cut, but it is a serious injury that can result in amputation. **Get immediate surgical treatment.**

- Do not point the gun at anyone or at any part of the body.
- Do not put your hand over the spray tip.
- Do not stop or deflect leaks with your hand, body, glove or rag.
- Do not spray without tip guard and trigger guard installed.
- Engage the gun trigger safety when you stop spraying.
- Follow the **Pressure Relief Procedure** on page 3 if the spray tip clogs and before cleaning, checking or servicing the equipment.

# Service

## Pressure Relief Procedure

**⚠ WARNING**

 **PRESSURIZED EQUIPMENT HAZARD**  
The system pressure must be manually relieved to prevent the system from starting or spraying accidentally. To reduce the risk of an injury from accidental spray from the gun, splashing fluid, or moving parts, follow the **Pressure Relief Procedure** whenever you:

- are instructed to relieve the pressure,
- stop spraying,
- check or service any of the system equipment,
- or install or clean the spray nozzle.

1. Engage gun safety latch.
2. Turn ON/OFF switch to OFF.
3. Unplug power cord.
4. Disengage gun safety latch. Hold metal part of gun against grounded metal pail and trigger gun into pail to relieve pressure.
5. Engage gun safety latch.
6. Open any fluid drain valves in system. Leave drain valve open until ready to dispense again.

## Pump Repair Kits

Pump	Repair Kit
248204, 255968	248212
253056	287825
248205, 249057, 249059	248213

## Tools Needed

Vise  
12 in. adjustable, open end wrench (2)  
Hammer, 20 oz maximum  
Small screwdriver  
Throat Seal Liquid  
Pick or long small screwdriver

## Cleaning and Inspecting Parts

1. Clean and inspect parts. Pay particular attention to the ball seats in the intake valve and piston, which must have no nicks or wear, and to the inside of the sleeve and the outside of the piston rod, which must not be worn or scratched. Replace worn or damaged parts.

**⚠ WARNING**

 **COMPONENT RUPTURE HAZARD**  
Never use sharp or pointed tools to remove sleeve or other components which could result in pump rupture and cause serious bodily injury. If the sleeve cannot be removed easily, return the sleeve and cylinder to your Graco distributor for removal.

2. Remove and clean the sleeve when you are repacking the pump.

# Service

## Repair When Pump Is Off The Sprayer

### Disassembling the pump

Fig. 1. Remove packing nut (202) and throat adjustment spacer (228).

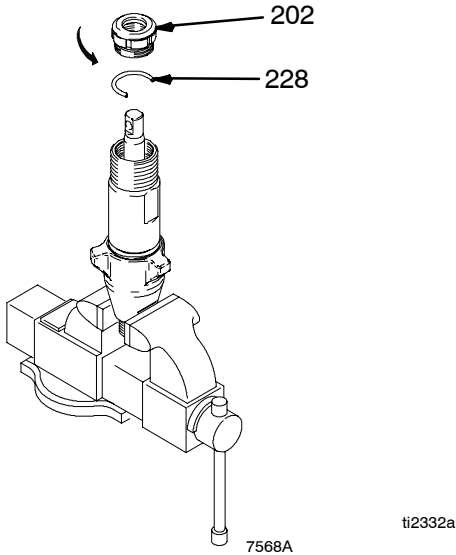

Fig. 1

Fig. 2. Unscrew intake valve from cylinder.

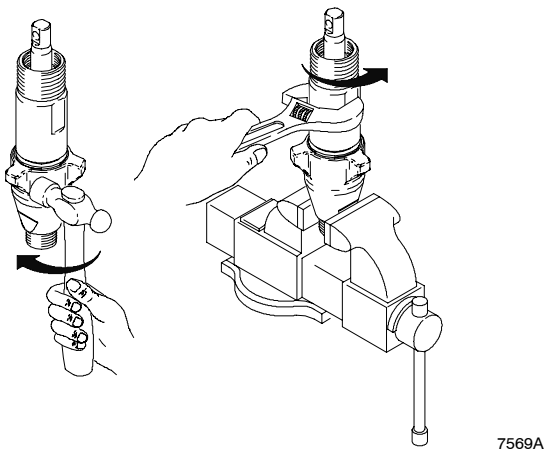

Fig. 2

Fig. 3. Disassemble intake valve. Clean and inspect. O-ring (227) may require a pick for removal.

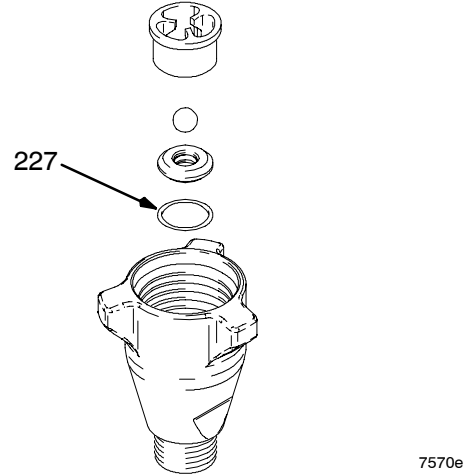

Fig. 3

Fig. 4. Tap piston rod out of cylinder with a hammer or flip over and tap piston rod out against a bench.

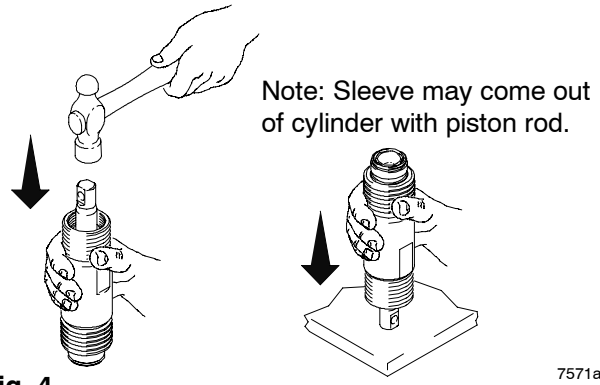

Fig. 4

Fig. 5. Remove piston rod from sleeve, or remove sleeve from cylinder. Mark IV: Remove sleeve spacer (230) from sleeve.

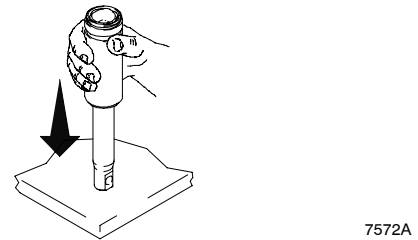

Fig. 5

# Service

**⚠ WARNING**

**COMPONENT RUPTURE HAZARD**  
 Do not clean or wipe the piston valve threads. Cleaning the piston valve threads could destroy the special sealing patch and cause the piston valve to come loose during operation, causing pump bursting and possible serious bodily injury.



Fig. 6. Unscrew piston valve from piston rod. Clean and inspect parts. The piston has a special thread locking/sealing patch. Do not remove the patch. The patch allows four disassembly/assembly procedures before it is necessary to apply Loctite® to the threads.

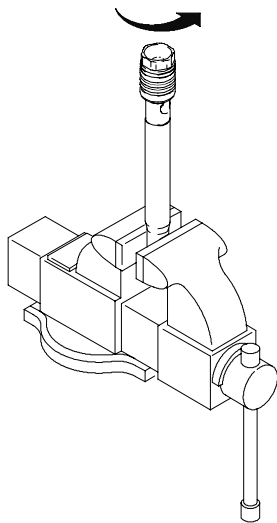

Fig. 6 7576A

Fig. 7. Remove packings and glands from piston rod.

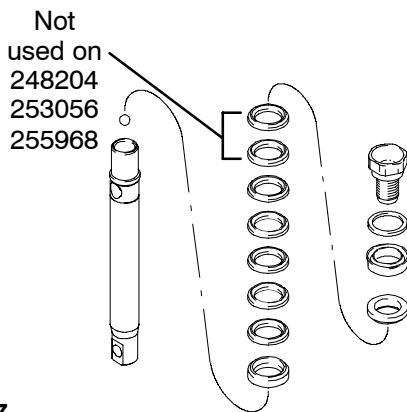

Fig. 7 ii3940b

Fig. 8. Remove throat packings and glands from cylinder. Discard throat packings and glands.

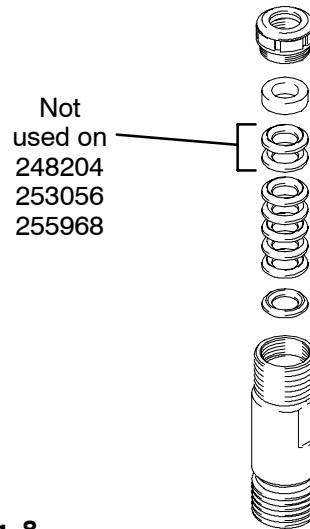

Fig. 8 7573B

## Assembling the pump

Fig. 9. Soak all leather packings in SAE 30W oil for 1 hour minimum prior to assembly. Stack male gland (204) on piston rod. Alternately stack UHMWPE (208) and leather (218) packings (note orientation) on piston rod. Install female gland (217). Install piston wiper (216) (note orientation) and backup washer (229) on piston valve (210). The special sealing patch on piston valve threads is good for four repackings. Use Loctite® on piston valve threads after four repackings.

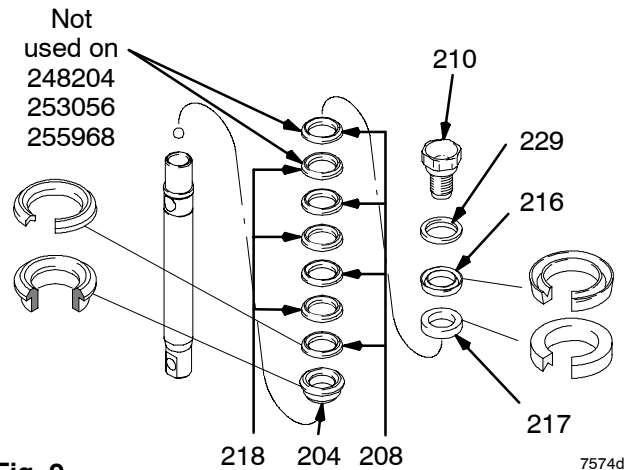

Fig. 9 7574d

# Service

Fig. 10. Install ball (206) in piston rod. If Loctite® is applied to piston valve threads, ensure that none gets on ball.

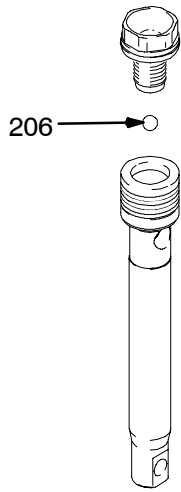

Fig. 10

7575A

Fig. 11. Tighten piston valve to piston rod as specified:

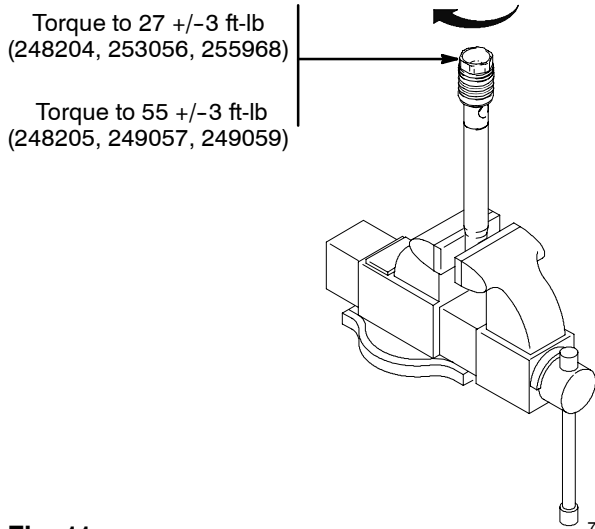

Fig. 11

7576A

Fig. 12. Soak all leather packings in SAE 30W oil for 1 hour minimum prior to assembly. Place male gland (204) in cylinder. Alternately stack UHMWPE (203) and leather packings (223) (note orientation). Place female gland (224) in top of cylinder. Seat packings.

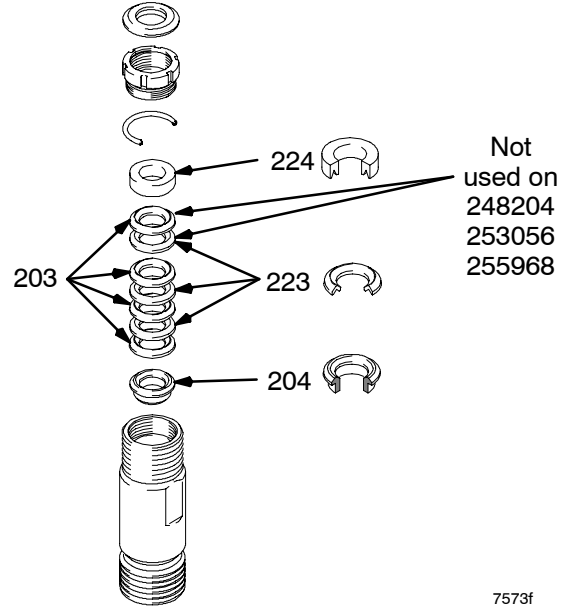

Fig. 12

7573f

Fig. 13. Install seal (201) into packing nut (202). Install throat adjustment spacer (228) onto packing nut. Loosely install packing nut into cylinder.

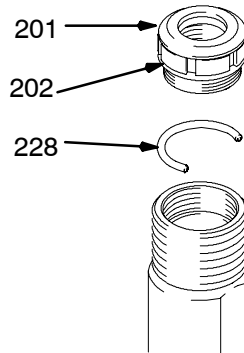

Fig. 13

7581A

# Service

Fig. 14. Grease piston packings.

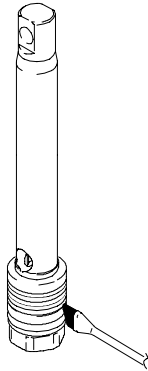

Fig. 14 ti7578c

**⚠ CAUTION**

Do not slide piston assembly into top of sleeve as this may damage piston packing.

Fig. 15. Slide piston assembly into bottom of sleeve.

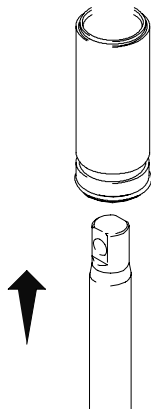

Fig. 15 7577A

Fig. 16. Grease top inch or two of piston rod that will go through the cylinder throat packings.

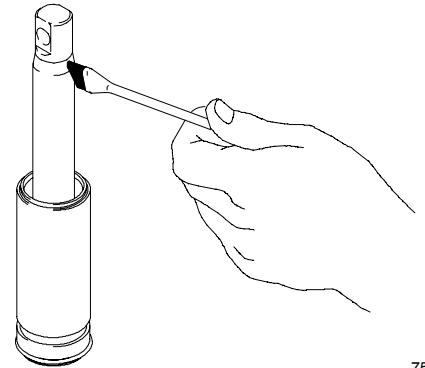

Fig. 16 7579A

Fig. 17. Grease o-rings (221) and place on sleeve. Slide sleeve/piston rod assembly into bottom of cylinder. Replace o-ring (207) if desired.

Note: O-ring (207) is not required for safe pump operation.

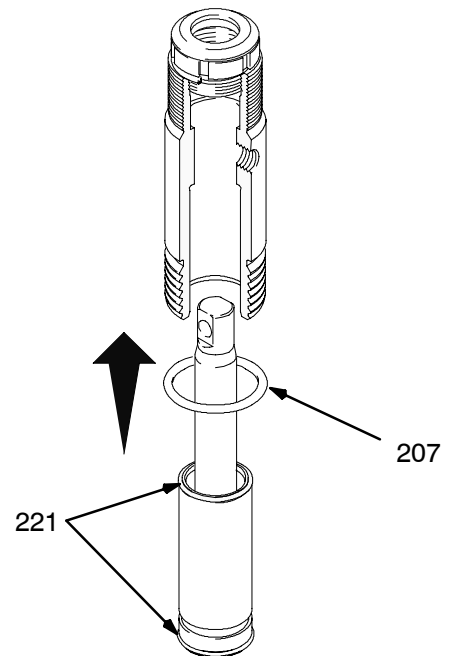

Fig. 17 7582A

# Service

Fig. 18. Mark IV: Install o-ring (231) on sleeve spacer (230) and install sleeve spacer on sleeve.

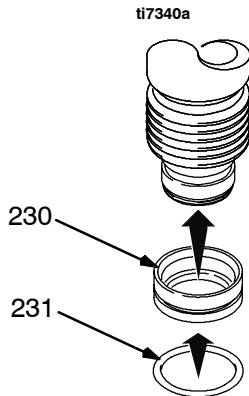

Fig. 18

Fig. 19. Reassemble intake valve with new o-ring (227), seat (212) and ball (214). Seat may be flipped over and used on other side. Clean seat thoroughly.

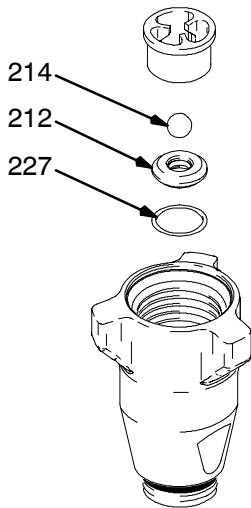

Fig. 19

Fig. 20. Install intake valve on cylinder. If a wrench is used torque as follows:

67 +/- 5 ft-lb (Model 248204, 253056, 255968)

80 +/- 5 ft-lb (Model 248205, 249057, 249059)

If a wrench is not used, be sure intake valve is bottomed out against cylinder.

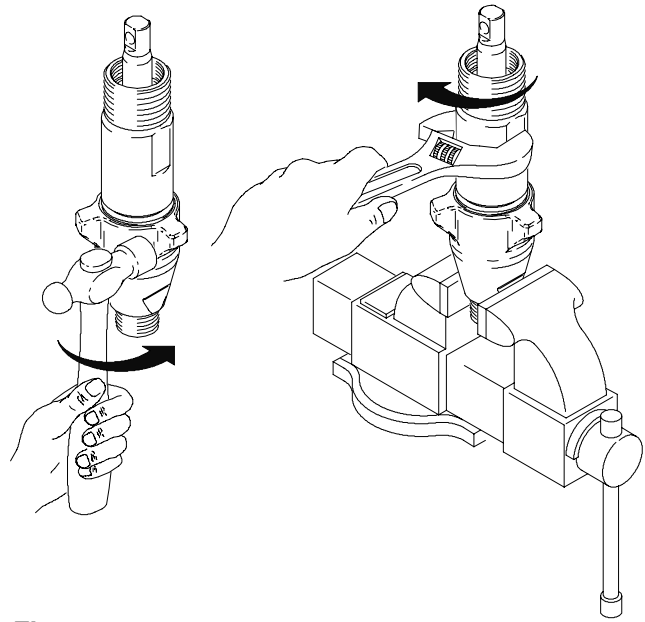

Fig. 20

Fig. 21. Torque packing nut (202) down onto adjustment spacer (228) 100 +/- 10 in-lb.

Remove throat adjustment spacer (228) when pump packings begin to leak after much use. Then tighten packing nut down until leakage stops or lessens. This allows approximately 100 gallons of additional operation before a repacking is required.

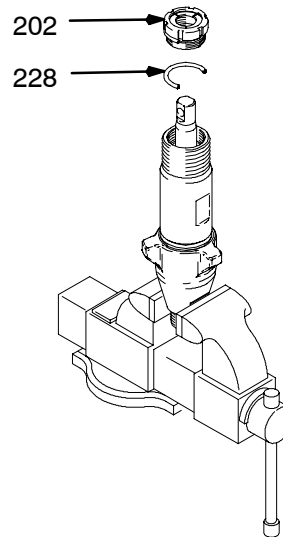

Fig. 21



# Service

## Repair When Pump Is On The Sprayer

**⚠ WARNING**

**SKIN INJECTION HAZARD**  
To reduce the risk of serious injury, whenever you are instructed to relieve pressure, follow the **Pressure Relief Procedure** on page 3.



Fig. 1. Remove intake valve.

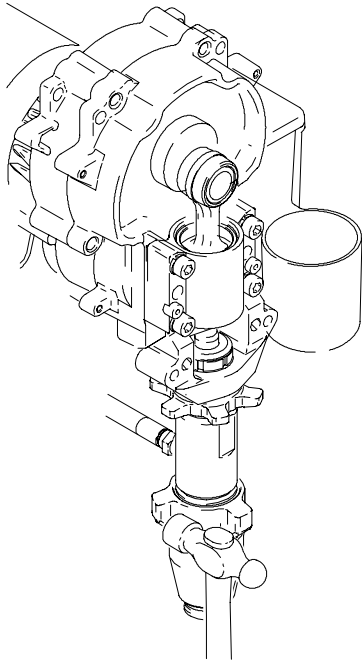

Fig. 1 ti4258a

Fig. 2. Push up retaining spring (26).

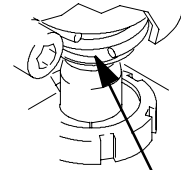
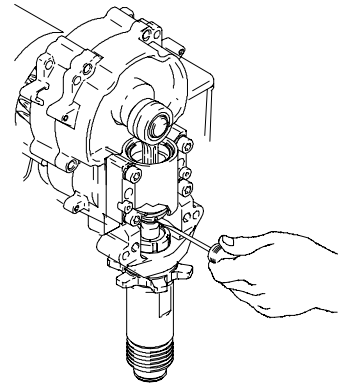

Fig. 2 26 ti4258a

Fig. 3. Push out pin (29).

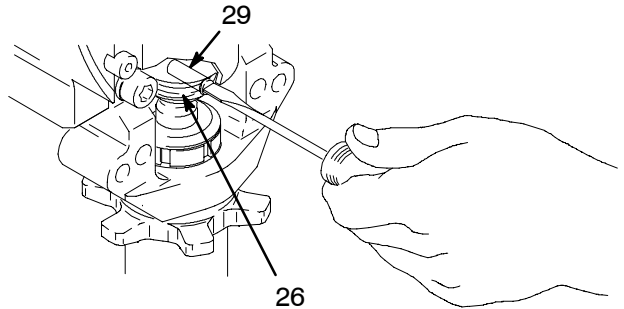

Fig. 3 26 ti4258a

Fig. 4. Disassemble intake valve. Clean and inspect. O-ring (227) may require a pick for removal.

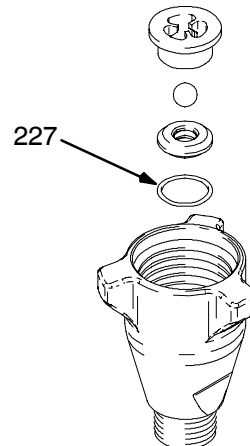
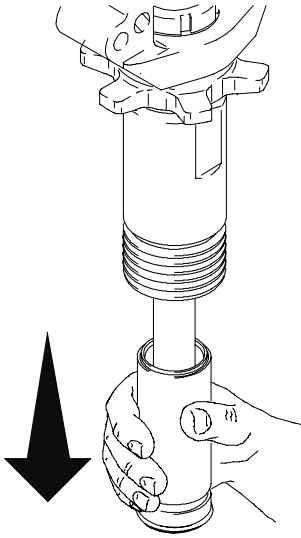

Fig. 4 7570A

# Service

Fig. 5. Remove piston rod and sleeve.



**Fig. 5** 7746A

Fig. 5. Invert piston rod and sleeve and pound on hard surface until piston rod comes out of sleeve. Mark IV: Remove sleeve spacer from sleeve.

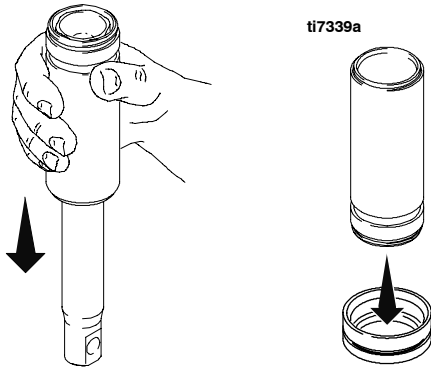

**Fig. 6** 7572A

Fig. 7. Remove packing nut (202)

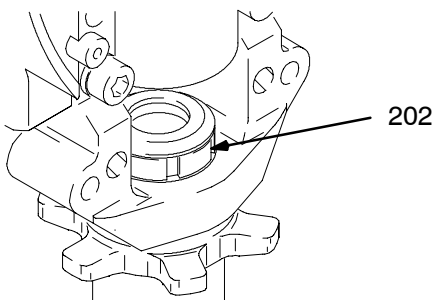

**Fig. 7** 7726A

Fig. 8. Invert piston rod and insert into cylinder to force out throat packings.

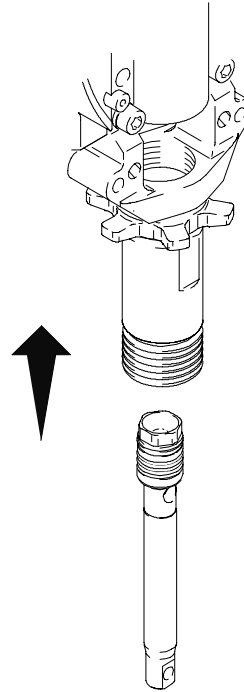

**Fig. 8** ti4258a

Fig. 9. Insert piston rod into cylinder with pin hole and piston valve down. Insert pin into piston rod and crank shaft.

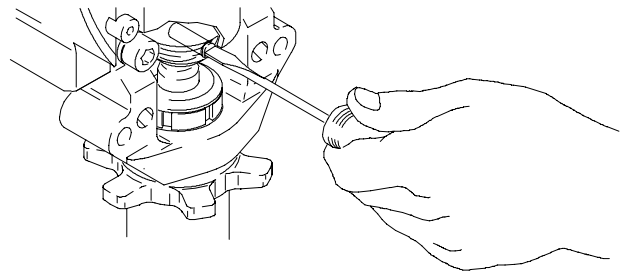

**Fig. 9** ti4258a

# Service

Fig. 10. Remove piston valve from piston rod with a wrench.

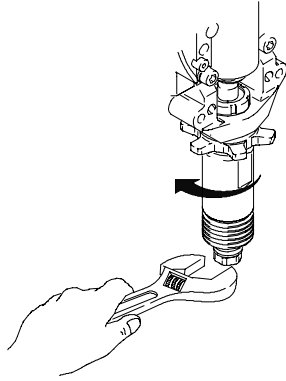

Fig. 10

ti4258a

Fig. 11. Remove pin and piston rod from cylinder.

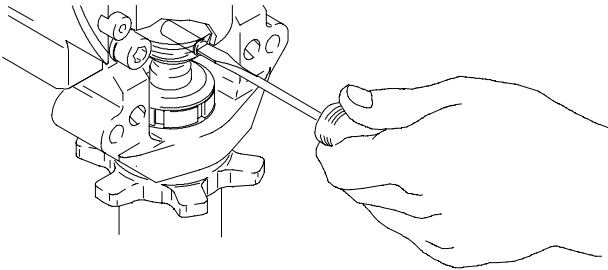

Fig. 11

ti4258a

Fig. 12. Soak all leather packings in SAE 30W oil for 1 hour minimum prior to assembly. Stack male gland (204). Alternately stack UHMWPE (203) and leather (223) packings (note orientation). Install female gland (224). Install seal (201) and packing nut (202) and throat adjustment spacer (228).

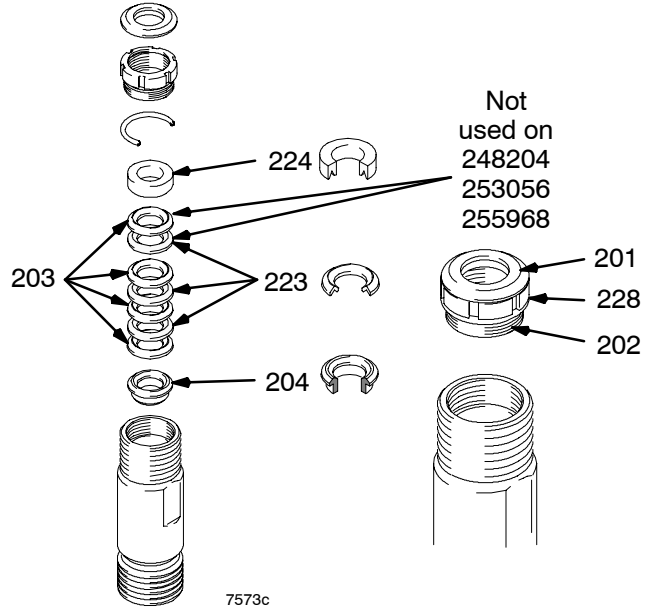

Fig. 12

Fig. 13. Remove packings and glands from piston rod.

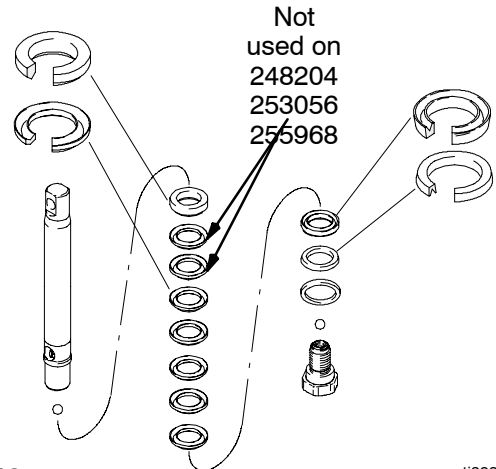

Fig. 13

ti3939a

# Service

Fig. 14. Soak all leather packings in SAE 30W oil for 1 hour minimum prior to assembly. Stack male gland (219) on piston rod. Alternately stack UHMWPE (208) and leather (218) packings (note orientation) on piston rod. Install female gland (217). Install piston wiper (216) and backup washer (229) (note orientation) on piston valve (210). The special sealing patch on piston valve threads is good for four repackings. Use Loctite® on piston valve threads after four repackings.

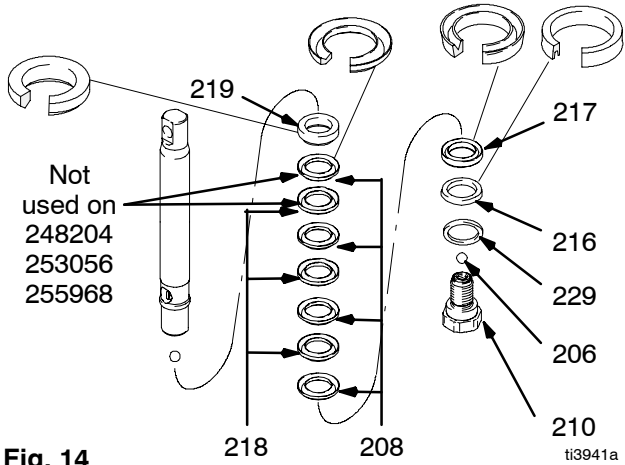

Fig. 14

Fig. 16. Grease piston packings.

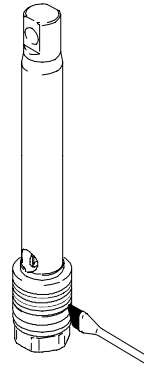

Fig. 16

**CAUTION**  
Do not slide piston assembly into top of sleeve as this may damage piston packing.

Fig. 17. Slide piston assembly into bottom of sleeve. Assure V-packing and u-cup are not rolled over or damaged. Mark IV: Install o-ring (231) on sleeve spacer (230). Install sleeve spacer on sleeve.

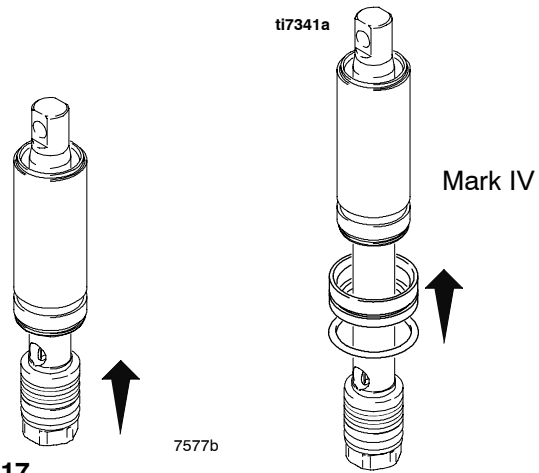

Fig. 17

Fig. 10. Install ball (206) in piston rod. If Loctite® is applied to piston valve threads, ensure that none gets on ball. Install piston valve on piston rod.

Torque as follows:

27 +/- 3 ft-lb (Model 248204, 253056, 255968)

55 +/- 3 ft-lb (Model 248205, 249057, 249059)

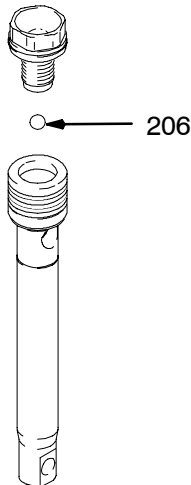

Fig. 15

Fig. 18. Grease top inch or two of piston rod that will go through the cylinder throat packings.

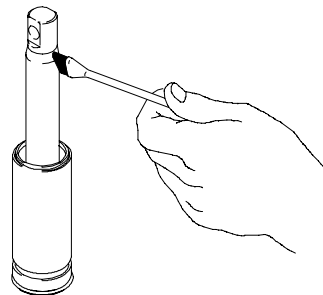

Fig. 18

# Service

Fig. 19. Grease o-ring (221) and place on sleeve. Slide sleeve/piston rod assembly into bottom of cylinder. Replace o-ring (207) if desired.

Note: O-ring (207) is not required for safe pump operation.

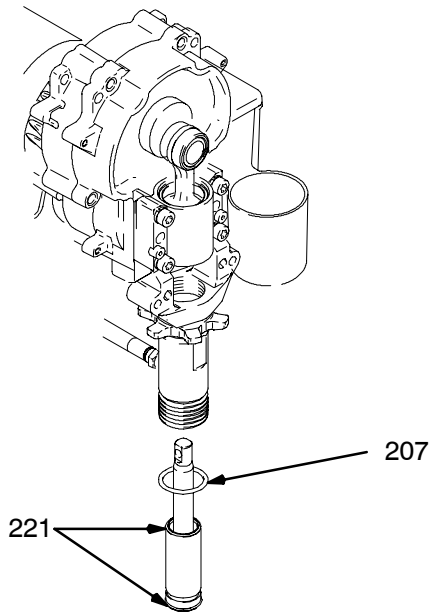

Fig. 19

ti4258a

Fig. 21. Torque seal and packing nut (202) down onto throat adjustment spacer (228) to 100 +/- 10 in-lb.

Remove throat adjustment spacer (228) when pump packings begin to leak after much use. Then tighten packing nut down until leakage stops or lessens. This allows approximately 100 gallons of additional operation before a repacking is required.

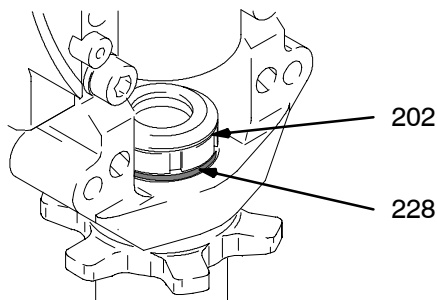

Fig. 20

7726b

Fig. 21. Push up retaining spring (26) with screwdriver.

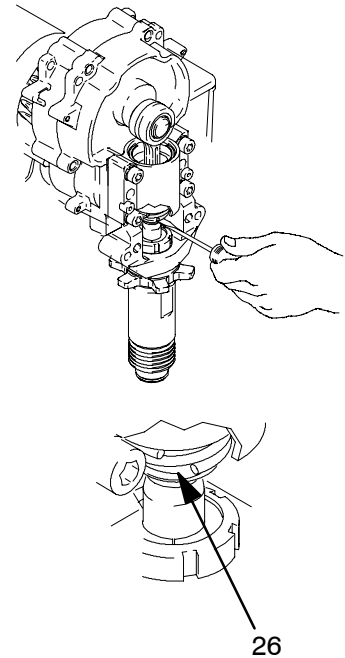

Fig. 21

ti4258a

Fig. 22. Push in pin (29).

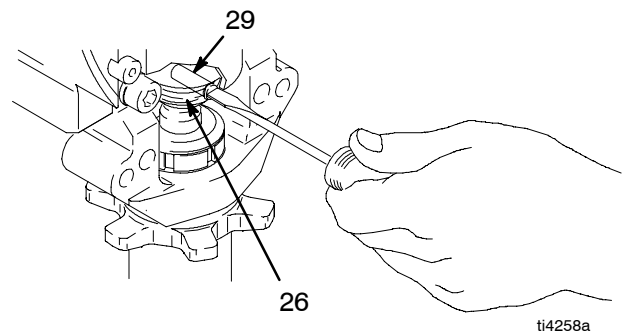

Fig. 22

Note: Make sure retaining ring falls into slot.

# Service

Fig. 23. Reassemble intake valve with new o-rings (227) and (230), seat (212) and ball (214). Seat may be flipped over and used on other side. Clean seat thoroughly.

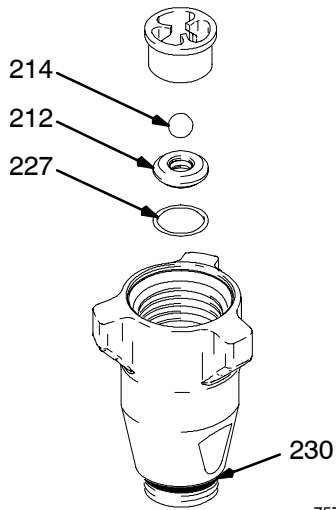

Fig. 23

7570f

Fig. 24. Install intake valve on cylinder. Torque:  
70 +/-5 ft-lb (model 248204, 253056, 255968)  
80 +/-5 ft-lb (Model 248205, 249057, 249059)

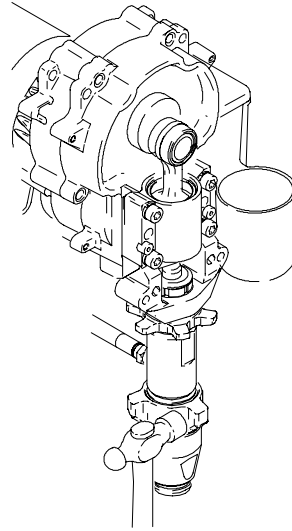

Fig. 24

ti4258a

# Service

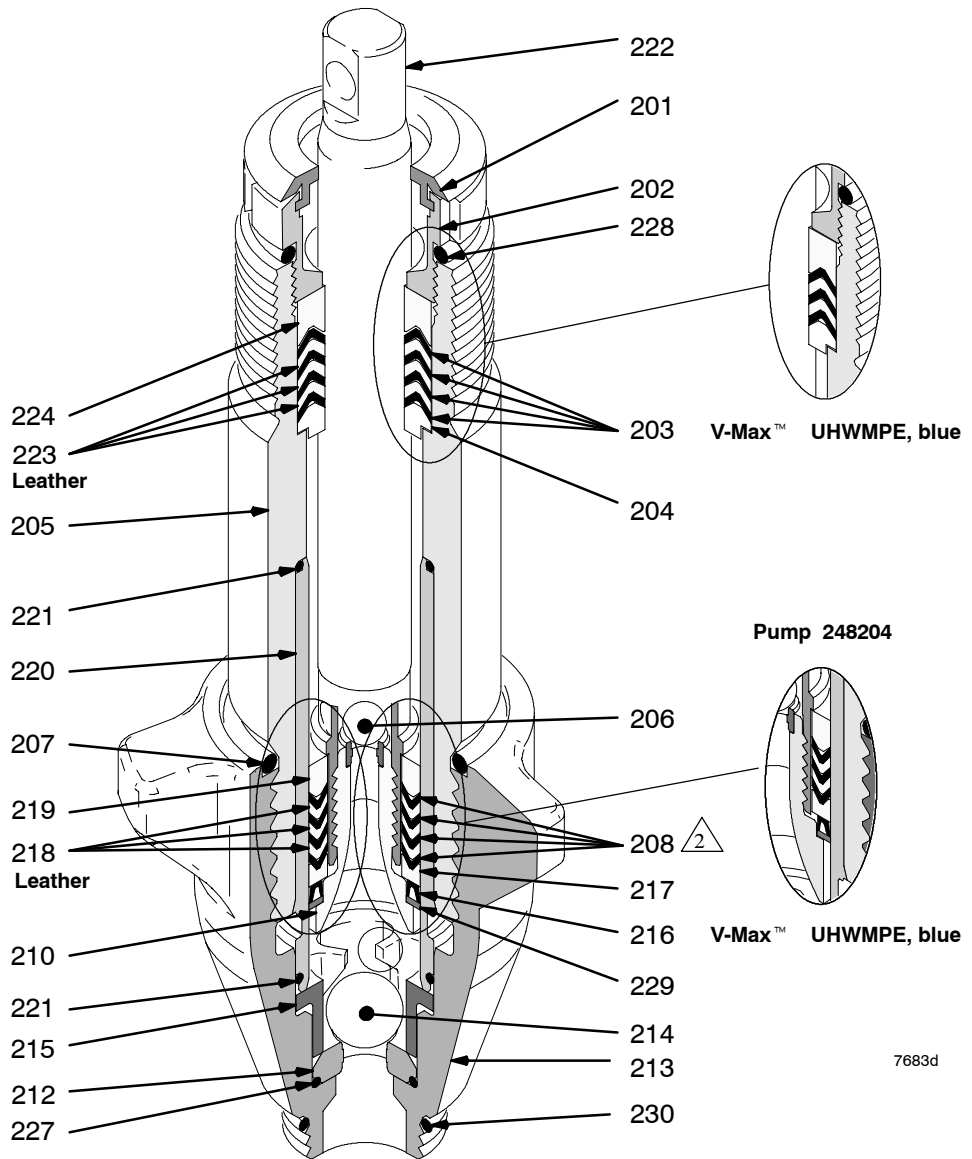

Fig 25

## Technical Data

Maximum working pressure ..... 3300 psi  
(227 bar, 22.7 MPa)  
Fluid inlet size ..... 1-5/16-12 un(m)

Fluid outlet size  
248204, 255968 ..... 1/4 npt(f)  
248205, 249057, 249059, 253056 ..... 3/8 npt(f)  
Wetted parts ..... stainless steel, PTFE, leather,  
nylon, zinc-plated carbon steel, tungsten carbide,  
chrome plating, fluoroelastomer, acetal, polyethylene

# Parts - Pump 248204, 277069, 255968

## Model 248204, Series A; 277069, Series A

Ref No.	Part No.	Description	Qty.
201	179810	SEAL, throat	1
202	193046	NUT, packing	1
203*	192692	V-PACKING, throat, V-Max™ UHMWPE, blue	3
204*	15C987	GLAND, male, throat	1
205	243346	Model 278204, 255968	1
	243346	Model 277069	1
206*	105444	BALL, sst, 0.3125 in.	1
207*	114054	PACKING, o-ring	1
208*	192693	V-PACKING, piston V-Max™ UHMWPE, blue	3
210	239932	VALVE, piston	1
212†	239922	KIT, seat, carbide includes 214 and 227	1
213	15C785	VALVE, intake (foot) Model 248204, 255968	1
	195892	VALVE, intake, Model 277069	1
214*†	105445	BALL, sst, 0.5000 in.	1
215	192624	GUIDE, ball	1
216*	118503	WIPER, piston	1
217*	178969	GLAND, female, piston	1
218*	178939	V-PACKING, leather, piston	2
219*	196880	GLAND, male	1
220	248209	SLEEVE, cylinder	1
221*	108526	O-RING, PTFE	2
222	248206	ROD, piston	1
223*	178940	V-PACKING, leather, throat	2
224*	15C988	GLAND, female	1
227*†	107079	PACKING, o-ring	1
228	192714	SPACER, throat, nut	1
229*	15C997	WASHER, backup	1
230*	118494	O-RING, fluoroelastomer (not used on Lo-boy)	1

\* These parts are also included in Repair Kit 248212, which may be purchased separately.

† These parts are also included in Carbide Seat Kit 239922, which may be purchased separately.

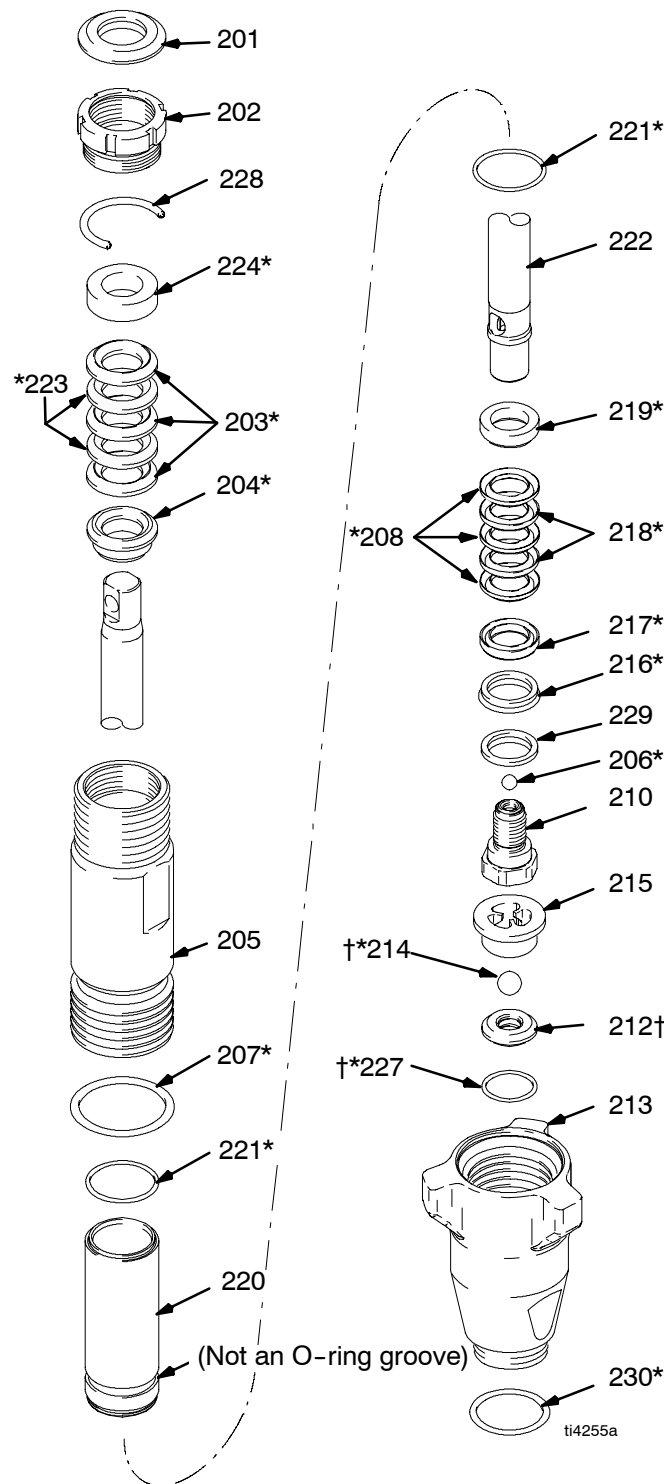



# Parts - Pumps 248205, 249057, 249059, 277070

Model 248205, Series A; 249057, Series A; 249059, Series A; 277070, Series A

Ref No.	Part No.	Description	Qty.
201+	183171	PLUG	1
202	193032	NUT, packing	1
203*+	193124	V-PACKING	4
		V-Max™ UHMWPE, blue	
204*+	15C989	GLAND, packing, male, throat	1
205	243347	CYLINDER, pump	1
206		BALL, 0.375 in.	
	101947*	Model 248205, 249057, 277070	1
		sst	
	116327+	Model 249059, ceramic	1
207*+	156633	PACKING, o-ring	1
208*+	193125	V-PACKING, piston	4
		V-Max™ UHMWPE, blue	
210	240150	VALVE, piston	1
212†		KIT, SEAT, carbide	
		includes 214 and 227	
	244199	Model 248205, 249057, 277070	1
	244571	Model 249059	1
213		HOUSING, intake (foot)	
	15C783	Model 248205, 249057	1
	196753	Model 249059	1
	195894	Model 277070	1
214		BALL	
	102972*†	Model 248205, 249057, 277070	1
		sst, 0.875 in.	
	111453+	Model 249059, ceramic, 0.750 in.	1
215		GUIDE, ball	
	196967	Model 249059, 249057	1
	193027	Model 248205, 277070	1
216*+	118504	WIPER, piston	1
217*+	183185	GLAND, female, piston	1
218*+	15E329	V-PACKING, leather, piston	3
219*+	183178	GLAND, packing, male	1
220	248210	SLEEVE, cylinder	1
221*+	107098	PACKING, o-ring	2
222		ROD, piston	
	248207	Model 248205, 277070	1
	249028	Model 249059, 249057	1
223*+	183175	V-PACKING, leather, throat	3
224*+	15C990	GLAND, packing, female	1
227*†+	108526	PACKING, o-ring	1
228+	C20987	SPACER, nut	1
229*+	15C998	WASHER, backup	1
230*+	118494	O-RING, fluoroelastomer	1
		(not used on 249057, 249059)	
231	117608	NIPPLE, straight	1
		Model 249057, 249059 (not shown)	
232	162485	ADAPTER, 3/8 npt x 3/8 npsm	1
		Model 249057, 249059 (not shown)	

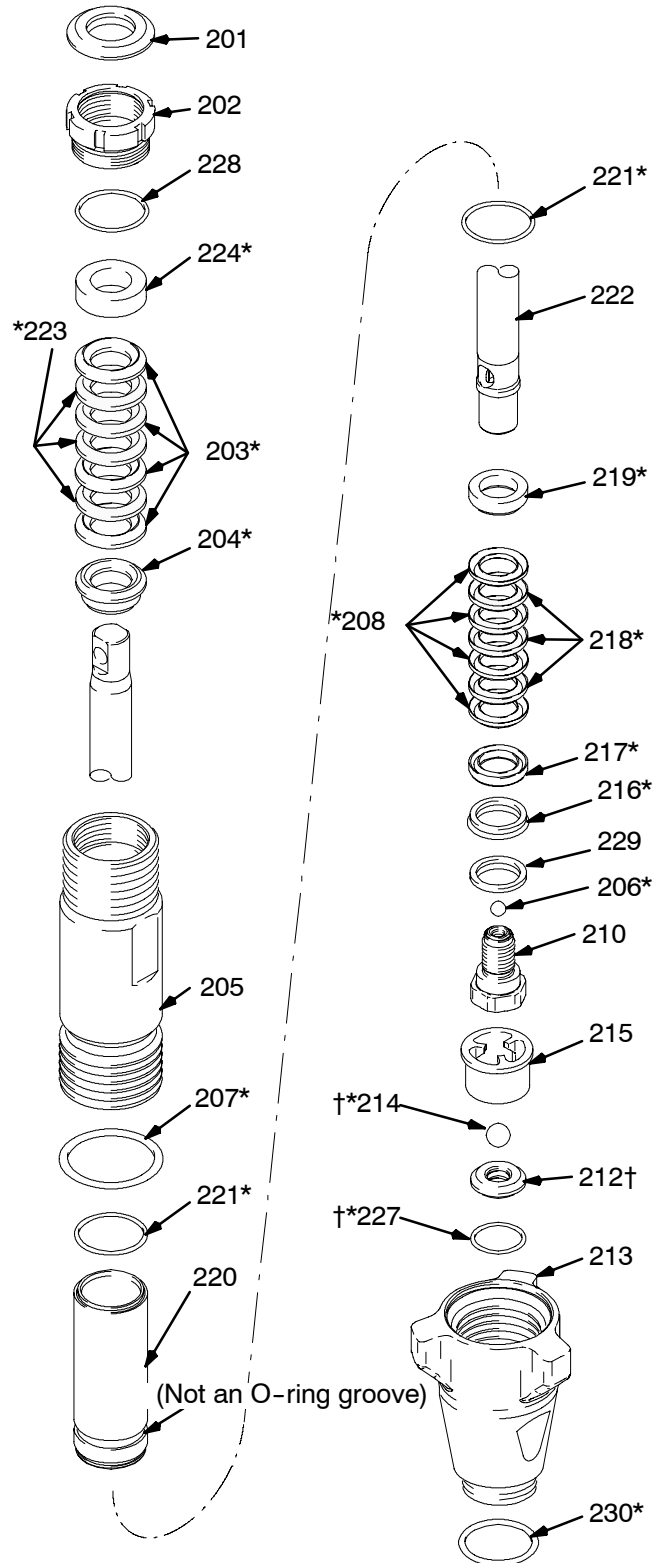

\* These parts are also included in Repair Kit 248213, which may be purchased separately.

† These parts are also included in Carbide Seat Kit 244199, which may be purchased separately

+ These parts are included in Pump Repair Kit 249189.

# Parts - Pump 253056

Ref No.	Part No.	Description	Qty.
201*	179810	SEAL, throat	1
202	193046	NUT, packing	1
203*	192692	V-PACKING, throat, V-Max™ UHMWPE, blue	3
204*	15C987	GLAND, male, throat	1
205	287876	CYLINDER, pump	1
206*	105444	BALL, sst, 0.3125 in.	1
207*	156593	PACKING, o-ring	1
208*	192693	V-PACKING, piston V-Max™ UHMWPE, blue	3
210	287877	VALVE, piston	1
212†	196866	SEAT, carbide	1
213	287878	HOUSING, intake	1
214*†	102972	BALL, sst, 0.875 in.	1
215	196967	GUIDE, ball	1
216*	118503	WIPER, piston	1
217*	178969	GLAND, female, piston	1
218*	178939	V-PACKING, leather, piston	2
219*	196880	GLAND, male	1
220	248209	SLEEVE, cylinder	1
221*	108526	O-RING, PTFE	2
222	249969	ROD, pump (MARK IV)	1
223*	178940	V-PACKING, leather, throat	2
224*	15C988	GLAND, female	1
227*†	108526	PACKING, o-ring	1
228*	158776	SPACER, throat, nut	1
229*	15C997	WASHER, backup	1
230	15G494	SPACER, sleeve	1
231	107098	O-RING	1

\* These parts are also included in Repair Kit 287825, purchased separately.

† These parts are also included in Carbide Seat Kit 244199, purchased separately.

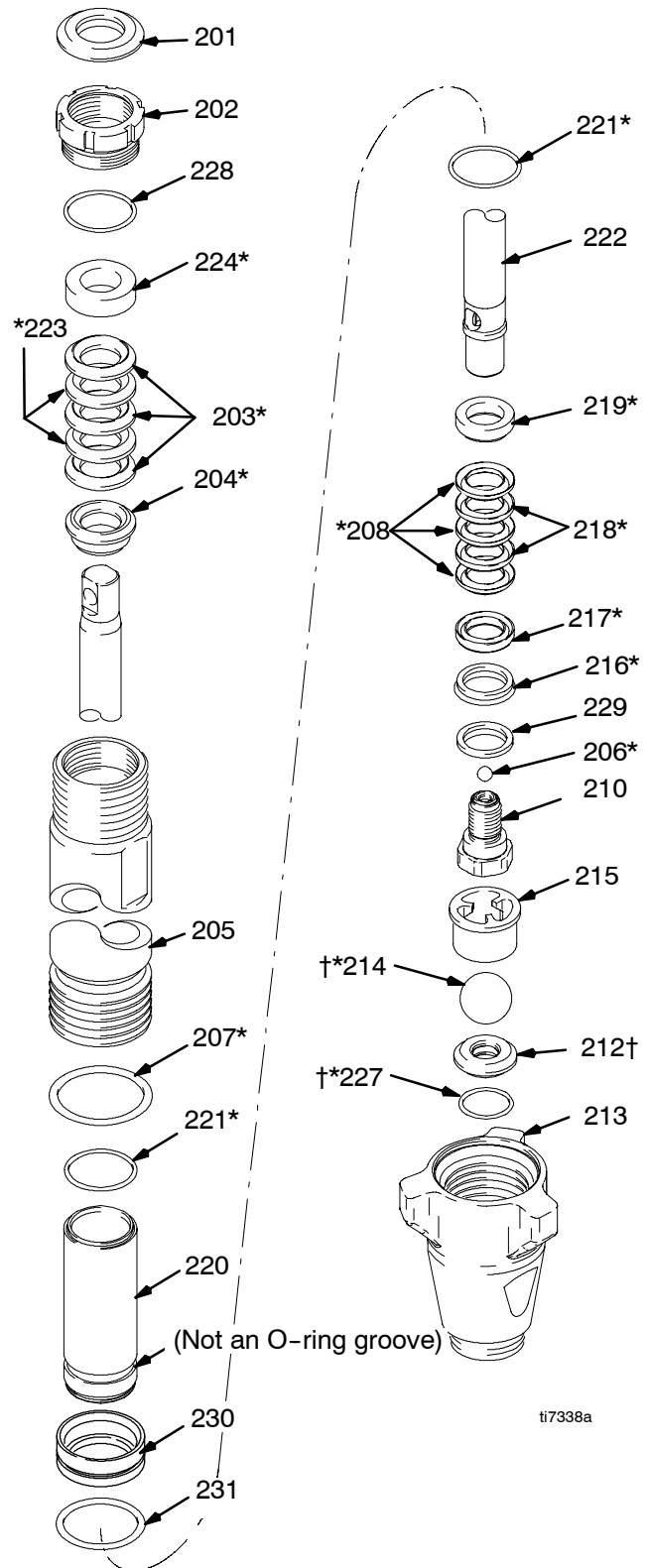



# Graco Standard Warranty

Graco warrants all equipment referenced in this document which is manufactured by Graco and bearing its name to be free from defects in material and workmanship on the date of sale to the original purchaser for use. With the exception of any special, extended, or limited warranty published by Graco, Graco will, for a period of twelve months from the date of sale, repair or replace any part of the equipment determined by Graco to be defective. This warranty applies only when the equipment is installed, operated and maintained in accordance with Graco's written recommendations.

This warranty does not cover, and Graco shall not be liable for general wear and tear, or any malfunction, damage or wear caused by faulty installation, misapplication, abrasion, corrosion, inadequate or improper maintenance, negligence, accident, tampering, or substitution of non-Graco component parts. Nor shall Graco be liable for malfunction, damage or wear caused by the incompatibility of Graco equipment with structures, accessories, equipment or materials not supplied by Graco, or the improper design, manufacture, installation, operation or maintenance of structures, accessories, equipment or materials not supplied by Graco.

This warranty is conditioned upon the prepaid return of the equipment claimed to be defective to an authorized Graco distributor for verification of the claimed defect. If the claimed defect is verified, Graco will repair or replace free of charge any defective parts. The equipment will be returned to the original purchaser transportation prepaid. If inspection of the equipment does not disclose any defect in material or workmanship, repairs will be made at a reasonable charge, which charges may include the costs of parts, labor, and transportation.

**THIS WARRANTY IS EXCLUSIVE, AND IS IN LIEU OF ANY OTHER WARRANTIES, EXPRESS OR IMPLIED, INCLUDING BUT NOT LIMITED TO WARRANTY OF MERCHANTABILITY OR WARRANTY OF FITNESS FOR A PARTICULAR PURPOSE.**

Graco's sole obligation and buyer's sole remedy for any breach of warranty shall be as set forth above. The buyer agrees that no other remedy (including, but not limited to, incidental or consequential damages for lost profits, lost sales, injury to person or property, or any other incidental or consequential loss) shall be available. Any action for breach of warranty must be brought within two (2) years of the date of sale.

**GRACO MAKES NO WARRANTY, AND DISCLAIMS ALL IMPLIED WARRANTIES OF MERCHANTABILITY AND FITNESS FOR A PARTICULAR PURPOSE, IN CONNECTION WITH ACCESSORIES, EQUIPMENT, MATERIALS OR COMPONENTS SOLD BUT NOT MANUFACTURED BY GRACO.** These items sold, but not manufactured by Graco (such as electric motors, switches, hose, etc.), are subject to the warranty, if any, of their manufacturer. Graco will provide purchaser with reasonable assistance in making any claim for breach of these warranties.

In no event will Graco be liable for indirect, incidental, special or consequential damages resulting from Graco supplying equipment hereunder, or the furnishing, performance, or use of any products or other goods sold hereto, whether due to a breach of contract, breach of warranty, the negligence of Graco, or otherwise.

## **FOR GRACO CANADA CUSTOMERS**

The parties acknowledge that they have required that the present document, as well as all documents, notices and legal proceedings entered into, given or instituted pursuant hereto or relating directly or indirectly hereto, be drawn up in English. Les parties reconnaissent avoir convenu que la rédaction du présente document sera en Anglais, ainsi que tous documents, avis et procédures judiciaires exécutés, donnés ou intentés à la suite de ou en rapport, directement ou indirectement, avec les procédures concernées.

## **ADDITIONAL WARRANTY COVERAGE**

Graco does provide extended warranty and wear warranty for products described in the "Graco Contractor Equipment Warranty Program".

**TO PLACE AN ORDER**, contact your Graco distributor, or call **1-800-690-2894** to identify the nearest distributor.

*All written and visual data contained in this document reflect the latest product information available at the time of publication.  
Graco reserves the right to make changes at any time without notice.*

This manual contains English. MM 310643

**Graco Headquarters:** Minneapolis  
**International Offices:** Belgium, China, Japan, Korea  
**GRACO INC. P.O. BOX 1441 MINNEAPOLIS, MN 55440-1441**  
www.graco.com  
12/2003, Revised 05/2008