

# Instructions - Parts List



## Important Safety Instructions

Read all warnings and instructions in this manual.  
Save these instructions.

# Displacement Pump

309277Z5

*3600 psi (250 bar, 24.8 MPa) Maximum Working Pressure*

### **Model 244197, Series A**

Ultra<sup>®</sup> Max and Ultimate Mx™ 795 and 1095  
GMax™ 3900

### **Model 244224, Series A**

Ultra Max and Ultimate Mx 1595  
GMax 5900 and 5900 Convertible

### **Model 244201, Series A**

245044, 245046, 245049 Mark V™  
GMax 5900HD

### **Model 245904 Series A**

245047 Mark V International (ceramic balls)

### **Model 244954, Series A, B, C**

HydraMax™ 225

### **Model 244957, Series A, B, C**

HydraMax 300/350

### **Model 245889, Series B**

Mark V SpackMax™

### **Model 246257, Series A**

GMax 7900, GH™ 200; Models 233940 - 233943

### **Model 248971, Series A**

GH 200; Models 248559 Series A - 248567 Series A  
EH™ 200

### **Model 248736, Series A**

248561 Series A, 248563 Series A  
GH 230, GH 300

### **Model 277068, Series A**

LineLazer™ IV 200 HS

### **Model 287815, Series A**

GH 230: Model 248561 Series B  
GH 300: Model 248563 Series B

### **Model 287814 Series A**

GH 200: Model 248559 Series B

### **Model 287946, Series A**

Mark X

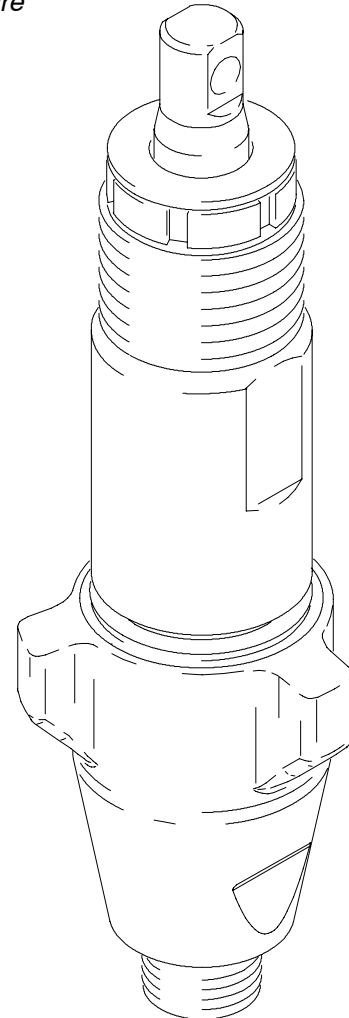

PROVEN QUALITY. LEADING TECHNOLOGY.

# Table of Contents

Warnings .....	2	244957 .....	20
Service .....	4	245889 .....	21
Technical Data .....	16	287946 .....	22
Parts, Pump		246257 .....	23
244197 .....	17	287815 .....	24
244224 .....	18	287814 .....	25
244201 .....	18	248736 .....	26
245904 .....	18	248971 .....	27
244954 .....	19	277068 .....	27
		Warranty .....	28

## Symbols

### Warning Symbol



This symbol alerts you to the possibility of serious injury or death if you do not follow the instructions.

### Caution Symbol



This symbol alerts you to the possibility of damage to or destruction of equipment if you do not follow the instructions.

# WARNING



INSTRUCTIONS

## EQUIPMENT MISUSE HAZARD

Equipment misuse can cause the equipment to rupture or malfunction and result in serious injury.

- This equipment is for professional use only.
- Read all instruction manuals, tags, and labels before operating the equipment.
- Use the equipment only for its intended purpose. If you are uncertain about usage, call your Graco distributor.
- Do not alter or modify this equipment. Use only genuine Graco parts and accessories.
- Do not exceed the maximum working pressure of the lowest rated system component. Refer to the **Technical Data** on page 16 for the maximum working pressure of this equipment.
- Use fluids and solvents compatible with the equipment wetted parts. Refer to the **Technical Data** section of all equipment manuals. Read the fluid and solvent manufacturer's warnings.
- Do not use 1,1,1-trichloroethane, methylene chloride, other halogenated hydrocarbon solvents or fluids containing such solvents in pressurized aluminum equipment. Such use could result in a chemical reaction, with the possibility of explosion.
- Comply with all applicable local, state, and national fire, electrical, and safety regulations.



## MOVING PARTS HAZARD

Moving parts can pinch or amputate your fingers.

- Keep clear of all moving parts when starting or operating the pump.
- Before servicing the equipment, follow the **Pressure Relief Procedure** on page 4 to prevent the equipment from starting unexpectedly.



## SKIN INJECTION HAZARD

High-pressure fluid from dispense valve, hose leaks, or ruptured components will pierce skin. This may look like just a cut, but it is a serious injury that can result in amputation. **Get immediate surgical treatment.**

- Do not point dispense valve at anyone or at any part of the body.
- Do not put your hand over the end of the dispense nozzle.
- Do not stop or deflect leaks with your hand, body, glove, or rag.

Follow Pressure Relief Procedure in this manual, when you stop spraying and before cleaning, checking, or servicing equipment.

# Service

## Pressure Relief Procedure

 **WARNING**



**PRESSURIZED EQUIPMENT HAZARD**  
The system pressure must be manually relieved to prevent the system from starting or spraying accidentally. To reduce the risk of an injury from accidental spray from the gun, splashing fluid, or moving parts, follow the **Pressure Relief Procedure** whenever you:

- are instructed to relieve the pressure,
- stop spraying,
- check or service any of the system equipment,
- or install or clean the spray nozzle.

1. Engage gun safety latch.
2. Turn ON/OFF switch to OFF.
3. Unplug power cord.
4. Disengage gun safety latch. Hold metal part of gun against grounded metal pail and trigger gun into pail to relieve pressure.
5. Engage gun safety latch.
6. Open any fluid drain valves in system. Leave drain valve open until ready to dispense again.

## Pump Repair Kits

Pump	Repair Kit
244197	248212
244224	248213
244201	248213
244954	246341
244957	244958
245889	245819
245904	244200
246257	246341
248736	246341
248971	246341
277068	246341
287814	287813
287815	287813
287946	287945

## Tools Needed

Vise  
 12 in. adjustable, open end wrench (2)  
 Hammer, 20 oz maximum  
 Small screwdriver  
 Throat Seal Liquid  
 Pick or long small screwdriver

## Cleaning and Inspecting Parts

1. Clean and inspect parts. Pay particular attention to the ball seats in the intake valve and piston, which must have no nicks or wear, and to the inside of the sleeve and the outside of the piston rod, which must not be worn or scratched. Replace worn or damaged parts.

 **WARNING**



**COMPONENT RUPTURE HAZARD**  
Never use sharp or pointed tools to remove sleeve or other components which could result in pump rupture and cause serious bodily injury. If the sleeve cannot be removed easily, return the sleeve and cylinder to your Graco distributor for removal.

2. Remove and clean the sleeve when you are repacking the pump.

# Service

## Repair When Pump Is Off The Sprayer

### Disassembling the pump

Fig. 1. Remove packing nut (202) and throat adjustment spacer (228).

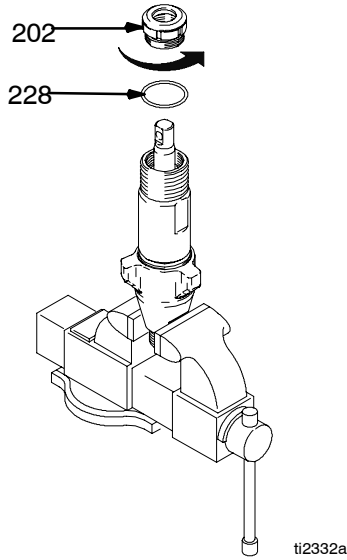

Fig. 1

Fig. 2. Unscrew intake valve from cylinder.

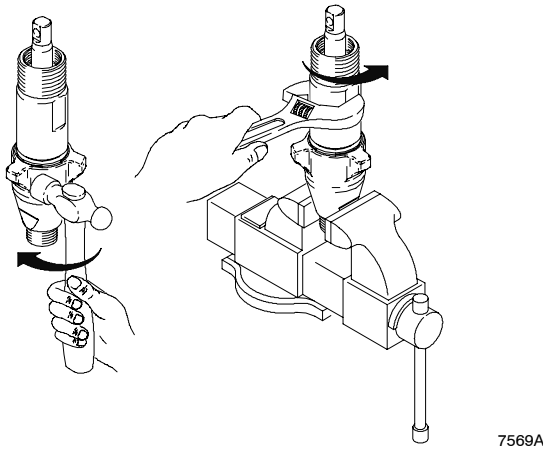

Fig. 2

Fig. 3. Disassemble intake valve. Clean and inspect. O-ring (227) may require a pick for removal.

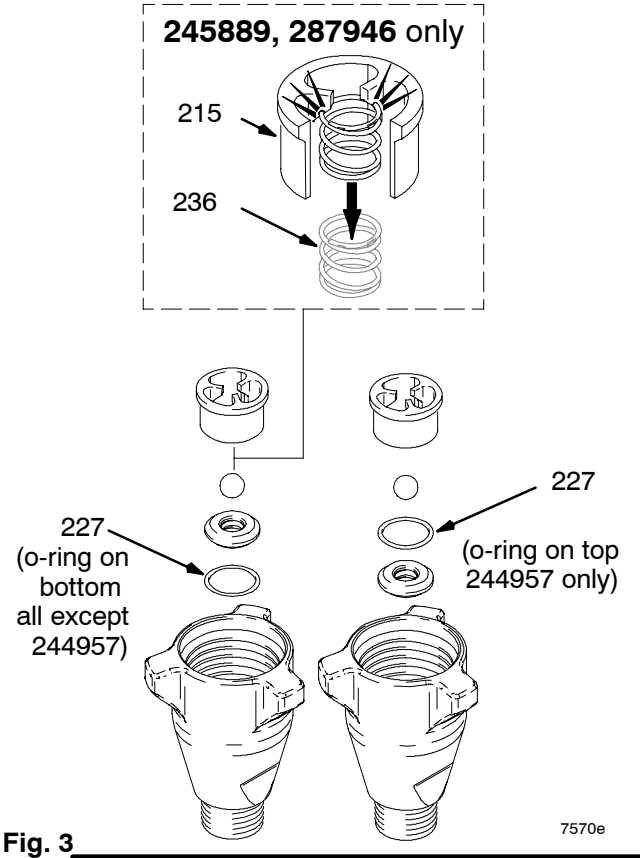

Fig. 3

Fig. 4. Tap piston rod out of cylinder with a hammer or flip over and tap piston rod out against a bench.

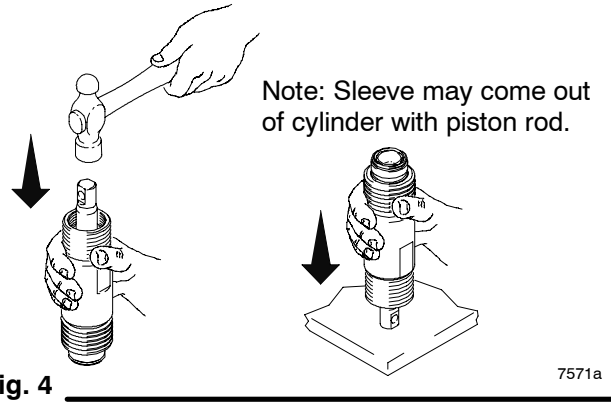

Fig. 4

Fig. 5. Remove piston rod from sleeve, or remove sleeve from cylinder.

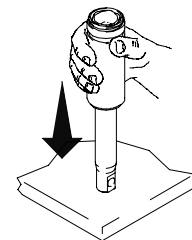

Fig. 5

# Service

## ⚠ WARNING

### COMPONENT RUPTURE HAZARD

Do not clean or wipe the piston valve threads. Cleaning the piston valve threads could destroy the special sealing patch and cause the piston valve to come loose during operation, causing pump bursting and possible serious bodily injury.



Fig. 6. Unscrew piston valve from piston rod. Clean and inspect parts. The piston has a special thread locking/sealing patch. Do not remove the patch. The patch allows four disassembly/assembly procedures before it is necessary to apply Loctite® to the threads.

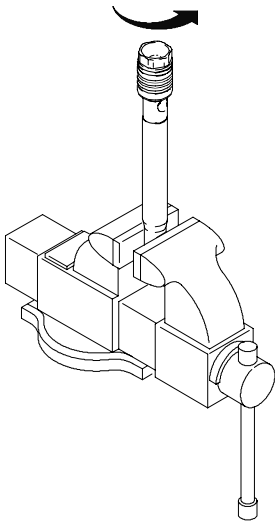

Fig. 6 7576A

Fig. 7. Remove packings and glands from piston rod.

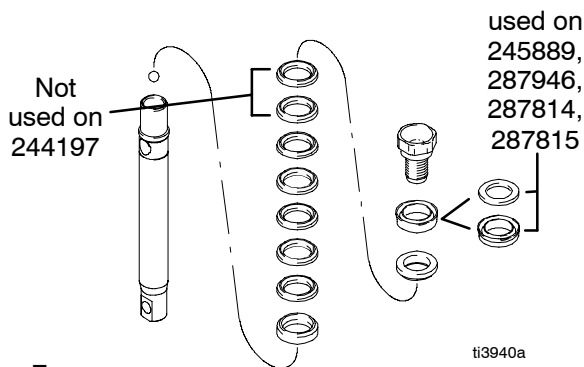

Fig. 7 ti3940a

Fig. 8. Remove throat packings and glands from cylinder. Discard throat packings and glands.

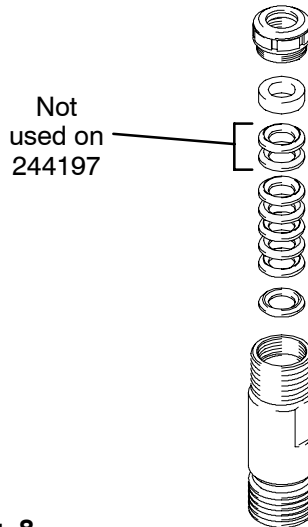
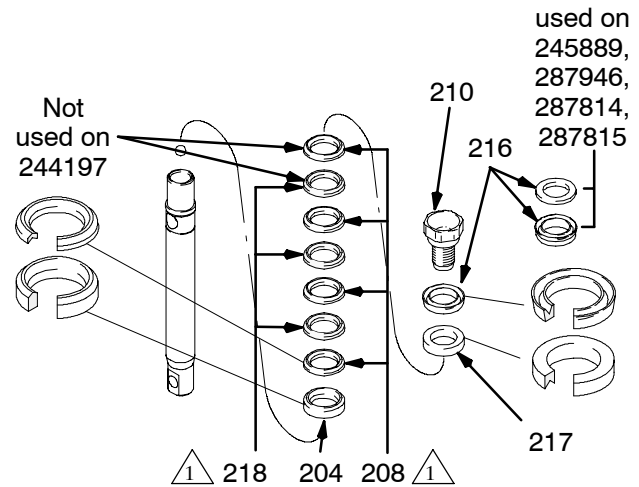

Fig. 8 7573B

## Assembling the pump

Fig. 9. Soak all leather packings in SAE 30W oil for 1 hour minimum prior to assembly. Stack male gland (204) on piston rod. Alternately stack UHMWPE (208) and leather (218) packings (note orientation) on piston rod. Install female gland (217). Install piston guide (216) (note orientation) on piston valve (210). The special sealing patch on piston valve threads is good for four repackings. Use Loctite® on piston valve threads after four repackings.



⚠ 244954, 246257, 245889; 208 and 218 are 203 and 223, respectively. 287946; 208 and 218 are 203 and 209, respectively. 7574c

Fig. 9

Note: Pump 287814 & 287815 do not use leather packings in piston stack. Alternately stack blue (208) and brown (218) packings on these pumps.

# Service

Fig. 10. Install ball (206) in piston rod. If Loctite® is applied to piston valve threads, ensure that none gets on ball.

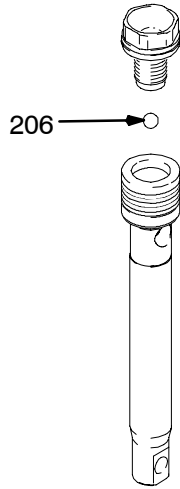

**Fig. 10** \_\_\_\_\_ 7575A

Fig. 12. Soak all leather packings in SAE 30W oil for 1 hour minimum prior to assembly. Place male gland (204) in cylinder. Alternately stack UHMWPE (203) and leather packings (223) (note orientation). Place female gland (224) in top of cylinder. Seat packings.

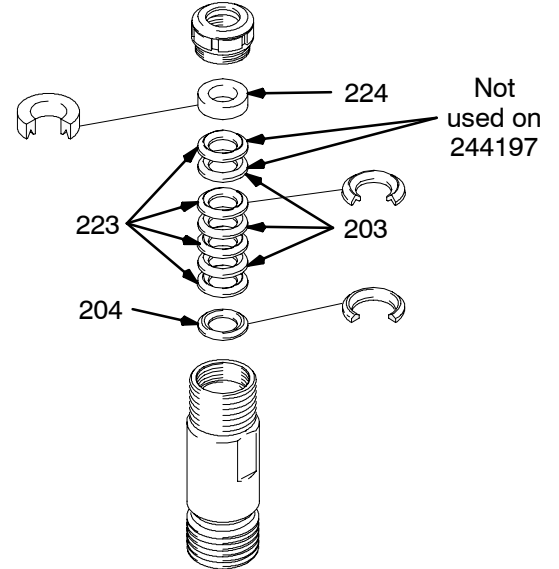

**Fig. 12** \_\_\_\_\_ 7573B

Fig. 11. Tighten piston valve to piston rod as specified:

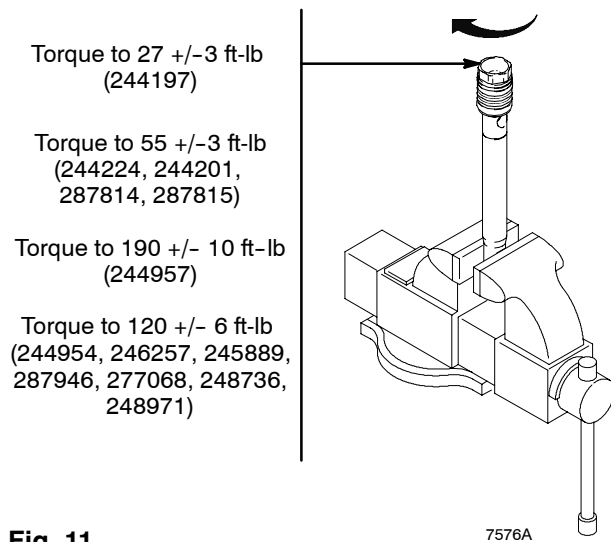

**Fig. 11** \_\_\_\_\_ 7576A

Fig. 13. Install seal (201) into packing nut (202). Install throat adjustment spacer (228) onto packing nut. Loosely install packing nut into cylinder.

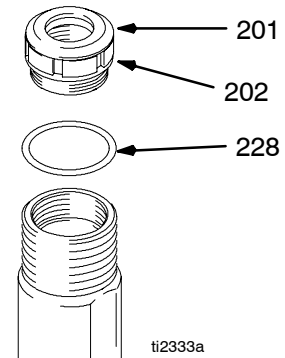

**Fig. 13** \_\_\_\_\_ ti2333a

# Service

Fig. 14. Grease piston packings and sleeve top edge.

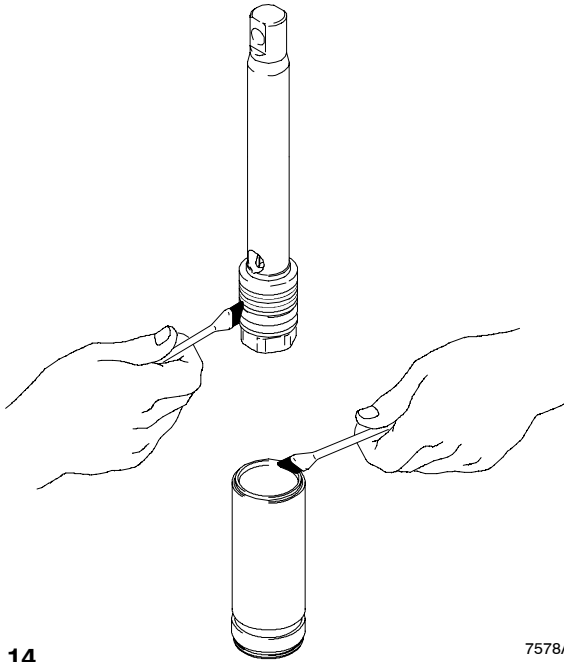

Fig. 14

7578A

Fig. 16. Grease top inch or two of piston rod that will go through the cylinder throat packings.

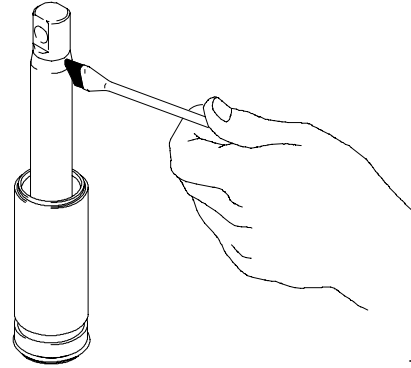

Fig. 16

7579A

Fig. 17. Grease o-ring (221) and place on sleeve. Slide sleeve/piston rod assembly into bottom of cylinder. Replace o-ring (207) if desired.

Note: O-ring (207) is not required for safe pump operation.

Fig. 15. Carefully slide piston assembly into top of sleeve.

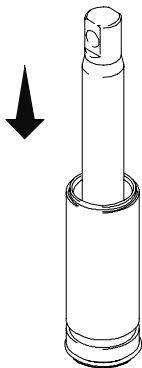

Fig. 15

7577A

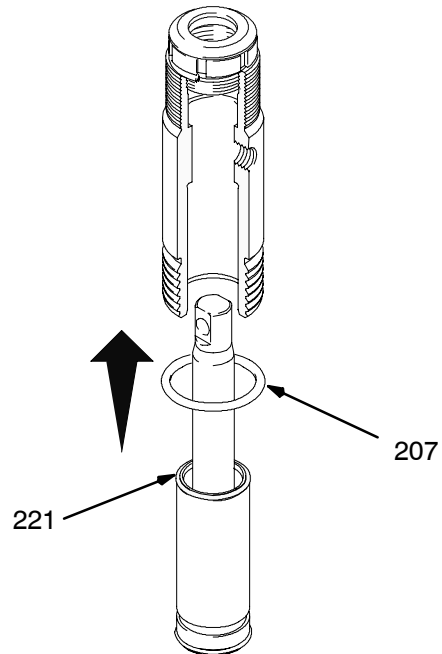

Fig. 17

7582A



# Service

Fig. 18. Reassemble intake valve with new o-ring (227), seat (212) and ball (214). Seat may be flipped over and used on other side. Clean seat thoroughly. Snap intake spring (236) into place inside ball guide (215).

Spring (236), for model 287946, is optional and not included with the pump.

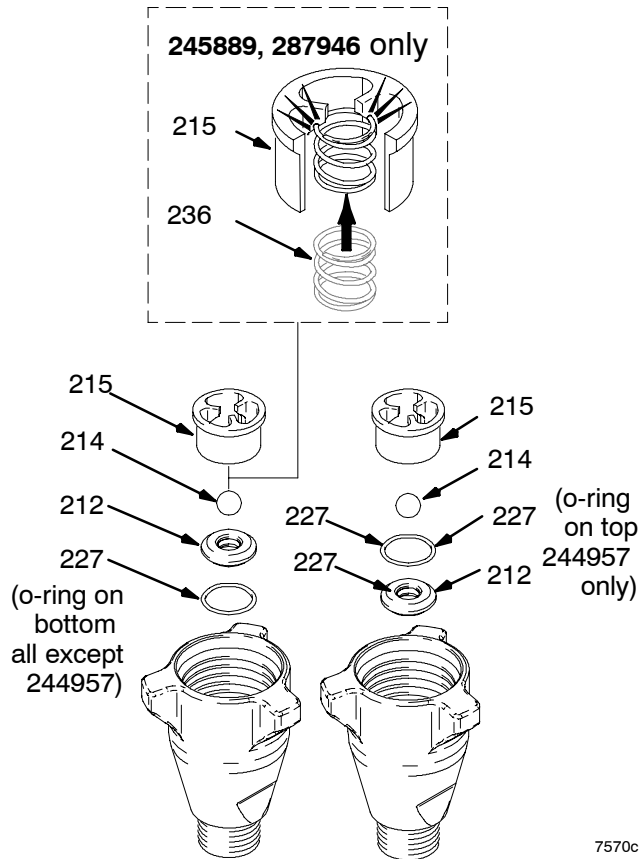
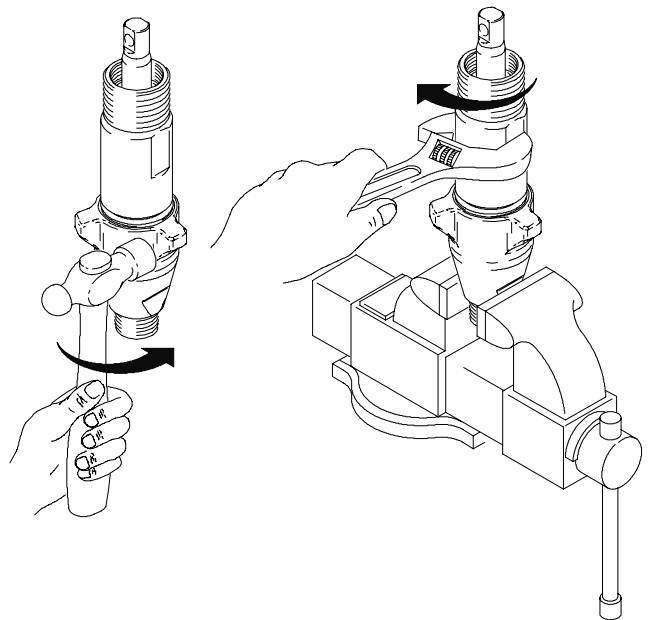

**Fig. 18**

Fig. 19. Install intake valve on cylinder. If a wrench is used torque as follows:

- 67 +/-5 ft-lb (model 244197)
- 80 +/-5 ft-lb (models 244201, 244224, 245904)
- 200 +/-10 ft-lb (models 244954, 246257, 245889, 287946, 277068, 248736, 248971)
- 200 +/-15 ft-lb (model 244957, 287814, 287815)

If a wrench is not used, be sure intake valve is bottomed out against cylinder.

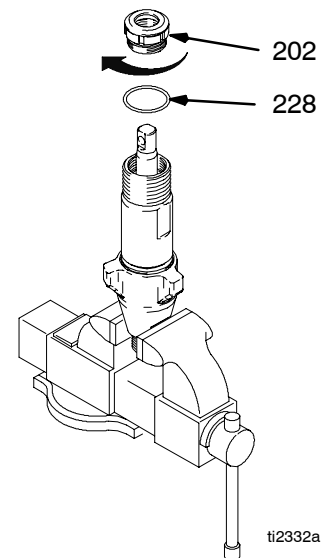

**Fig. 19**

7569A

Fig. 20. Torque seal and packing nut (202) down onto throat adjustment spacer (228) to 100 +/-10 in-lb (75 +/-5 in-lb for 246257) (140 +/-10 in-lb for 287814, 287815).

Remove throat adjustment spacer (228) when pump packings begin to leak after much use. Then tighten packing nut down until leakage stops or lessens. This allows approximately 100 gallons of additional operation before a repacking is required.



**Fig. 20**

ti2332a

# Service

## Repair When Pump Is On The Sprayer

**⚠ WARNING**

**SKIN INJECTION HAZARD**  
To reduce the risk of serious injury, whenever you are instructed to relieve pressure, follow the **Pressure Relief Procedure** on page 4.



Fig. 1. Remove intake valve.

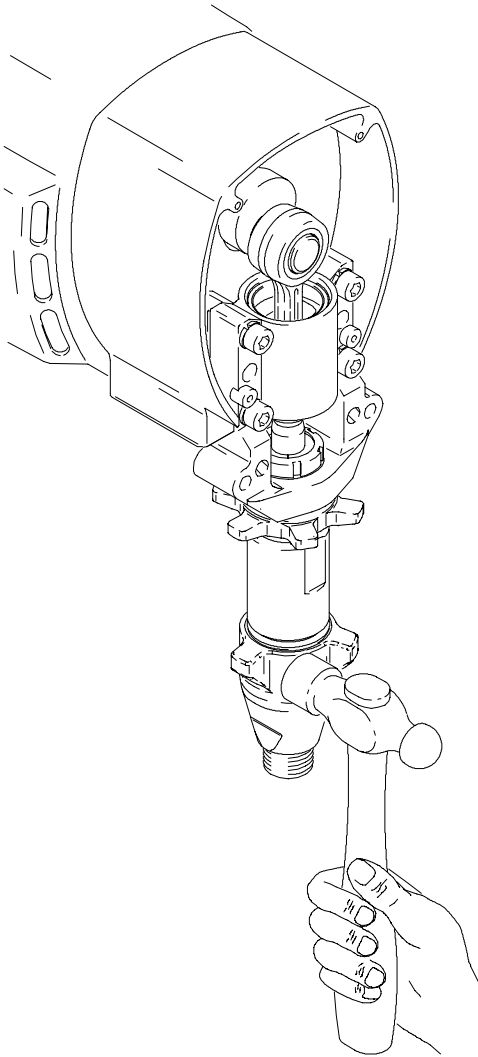

Fig. 1

7673A

Fig. 2. Use screwdriver to push retaining spring up and push pin out.

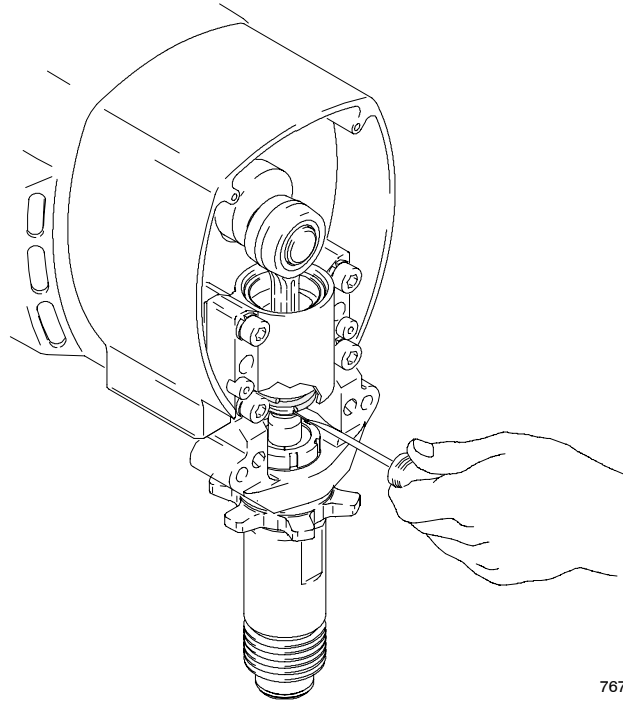

Fig. 2

7674A

Fig. 3. Disassemble intake valve. Clean and inspect. O-ring (227) may require a pick for removal.

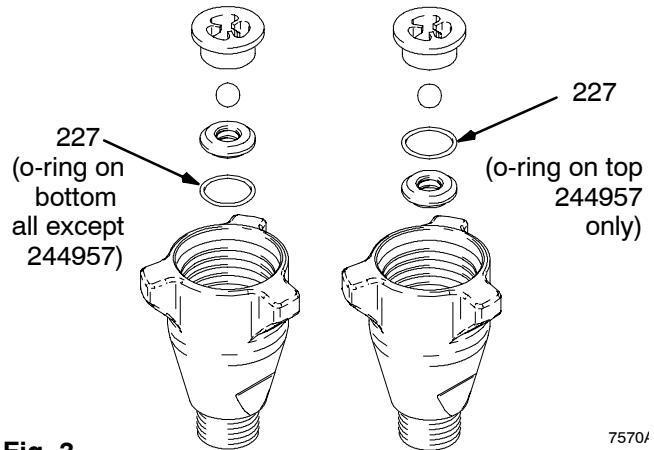
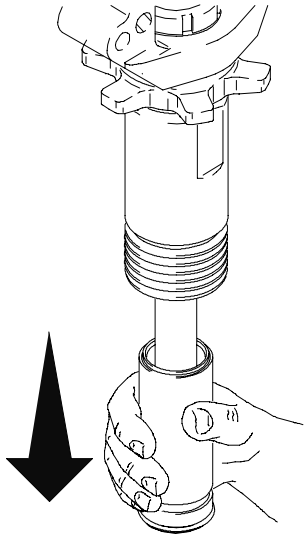

Fig. 3

7570A

# Service

Fig. 4. Remove piston rod and sleeve.



**Fig. 4**

7746A

Fig. 4. Invert piston rod and sleeve and pound on hard surface until piston rod comes out of sleeve.

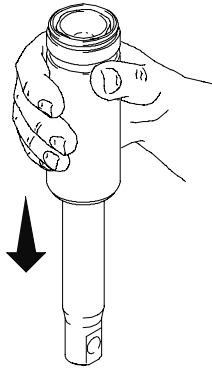

**Fig. 5**

7572A

Fig. 6. Remove packing nut (202)

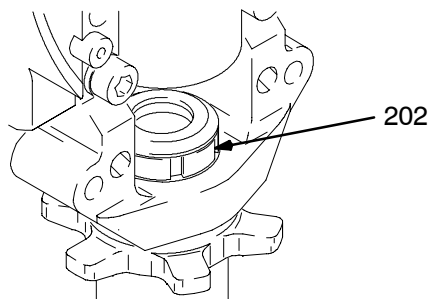

**Fig. 6**

7726A

Fig. 7. Invert piston rod and insert into cylinder to force out throat packings.

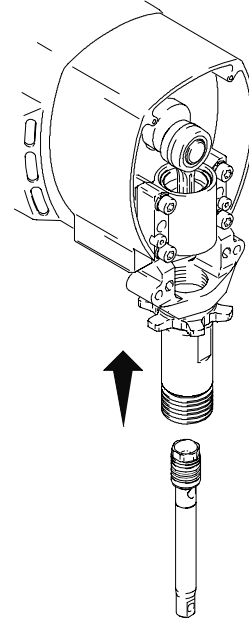

**Fig. 7**

7747A

Fig. 8. Insert piston rod into cylinder with pin hole up and piston valve down. Insert pin into piston rod and crank shaft.

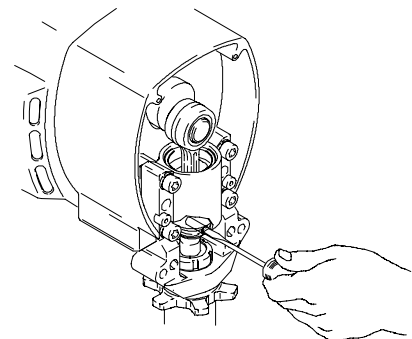
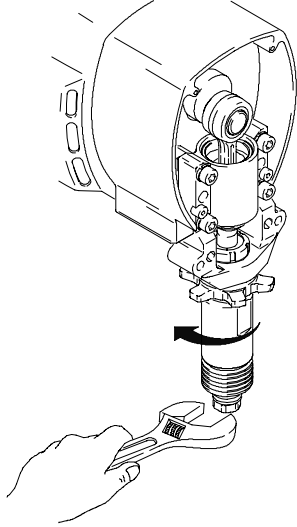

**Fig. 8**

7675A

# Service

Fig. 9. Remove piston valve from piston rod with a wrench.



7748A

Fig. 9

Fig. 11. Soak all leather packings in SAE 30W oil for 1 hour minimum prior to assembly. Stack male gland (204). Alternately stack UHMWPE (203) and leather (223) packings (note orientation). Install female gland (224). Install seal (201) and packing nut (202) and throat adjustment spacer (228).

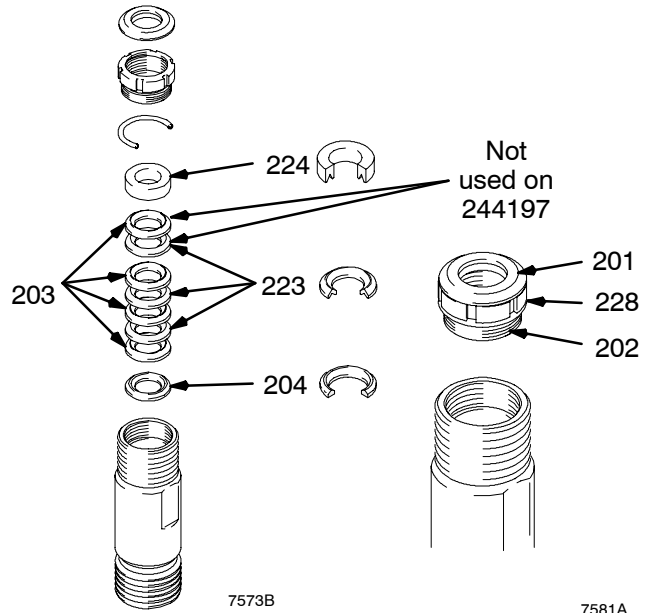

7573B

7581A

Fig. 11

Fig. 10. Remove pin and piston rod from cylinder.

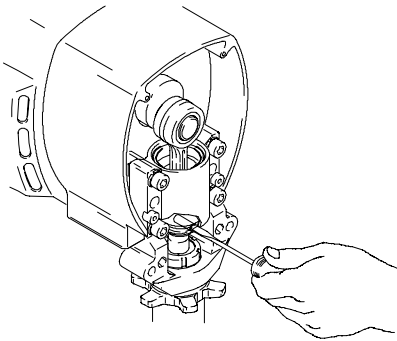

7675A

Fig. 10

Fig. 12. Remove packings and glands from piston rod.

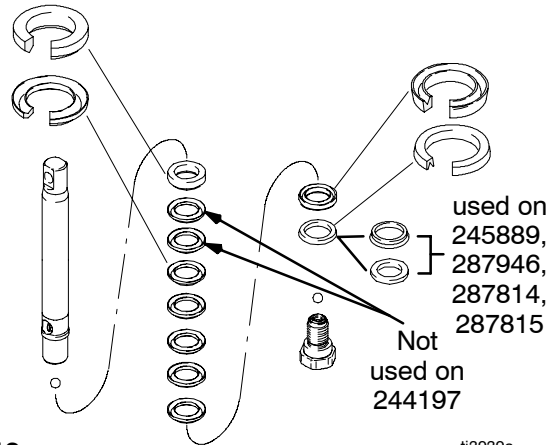

ti3939a

Fig. 12

# Service

Fig. 13. Soak all leather packings in SAE 30W oil for 1 hour minimum prior to assembly. Stack male gland (219) on piston rod. Alternately stack UHMWPE (208) and leather (218) packings (note orientation) on piston rod. Install female gland (217). Install piston guide (216) (note orientation) on piston valve (210). The special sealing patch on piston valve threads is good for four repackings. Use Loctite® on piston valve threads after four repackings.

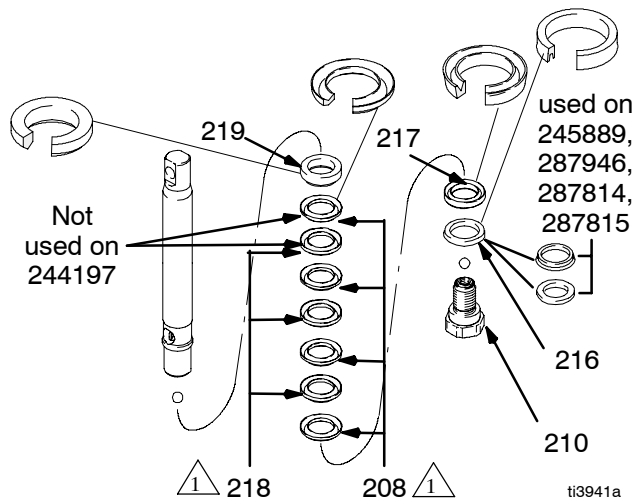

⚠ 244954, 246257, 245889; 208 and 218 are 203 and 223, respectively. 287946; 208 and 218 are 203 and 209, respectively.

**Fig. 13**

Note: Pump 287814 & 287815 do not use leather packings in piston stack. Alternately stack blue (208) and brown (218) packings on these pumps.

Fig. 10. Install ball (206) in piston rod. If Loctite® is applied to piston valve threads, ensure that none gets on ball. Install piston valve on piston rod.

Torque as follows:

27 +/-3 ft-lb (for model 244197)

55 +/-3 ft-lb (for models 244224, 244201, 245904, 287814, 287815)

120 +/- 6 ft-lb (for models 244954, 246257, 245889, 287946, 277068, 248736, 248971)

190 +/-10 ft-lb (for model 244957)

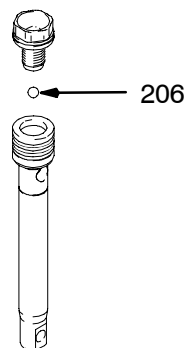

**Fig. 14**

7575A

Fig. 15. Grease piston packings and sleeve top edge.

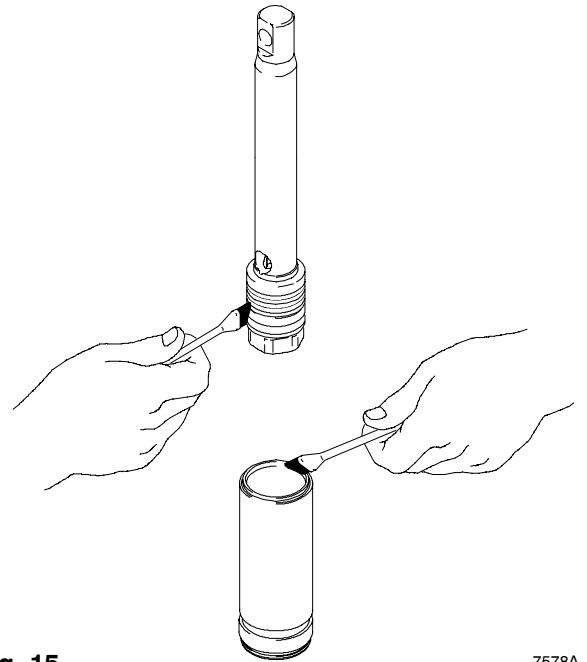

**Fig. 15**

7578A

Fig. 16. Carefully slide piston assembly into top of sleeve. Assure u-cup is not rolled over or damaged.

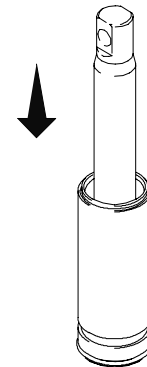

**Fig. 16**

7577A

Fig. 17. Grease top inch or two of piston rod that will go through the cylinder throat packings.

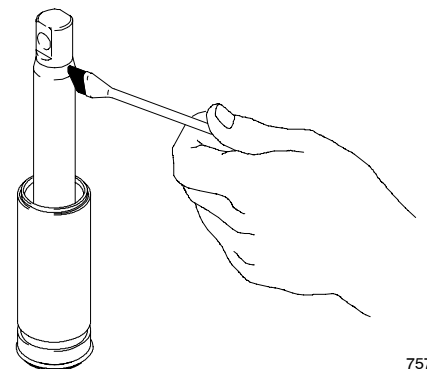

**Fig. 17**

7579A

# Service

Fig. 18. Grease o-ring (221) and place on sleeve. Slide sleeve/piston rod assembly into bottom of cylinder. Replace o-ring (207) if desired.

Note: O-ring (207) is not required for safe pump operation.

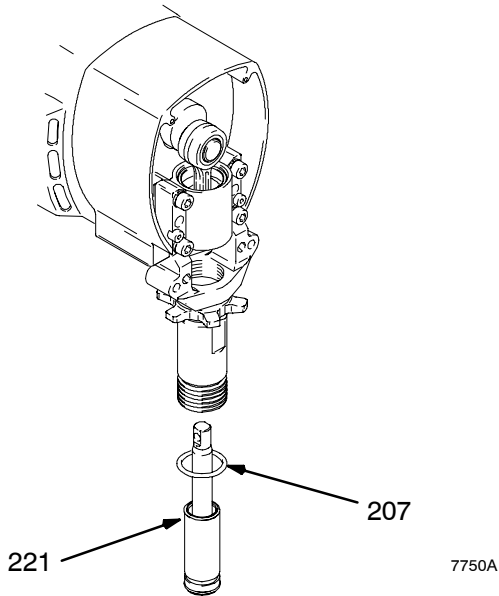

**Fig. 18**

Fig. 20. Torque seal and packing nut (202) down onto throat adjustment spacer (228) to 100 +/- 10 in-lb (75 +/- 5 in-lb for 246257) (140 +/- 10 in-lb for 287814, 287815).

Remove throat adjustment spacer (228) when pump packings begin to leak after much use. Then tighten packing nut down until leakage stops or lessens. This allows approximately 100 gallons of additional operation before a repacking is required.

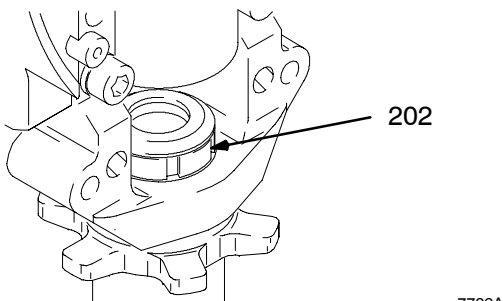

**Fig. 19**

Fig. 20. Use screwdriver to push retaining spring up.

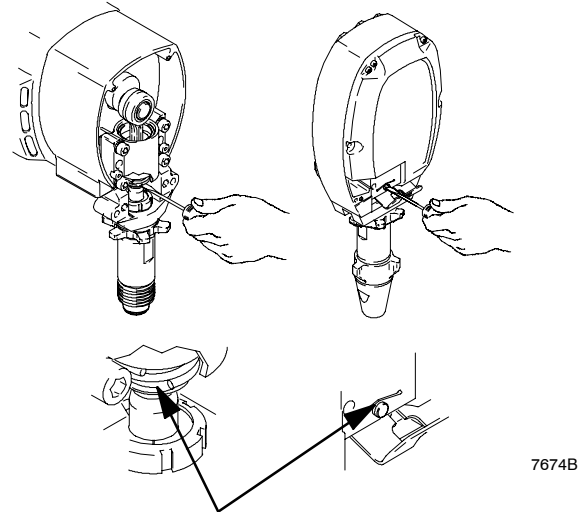

**Fig. 20** **Note:** Make sure retaining ring falls into slot.

Fig. 21. Push in pin.

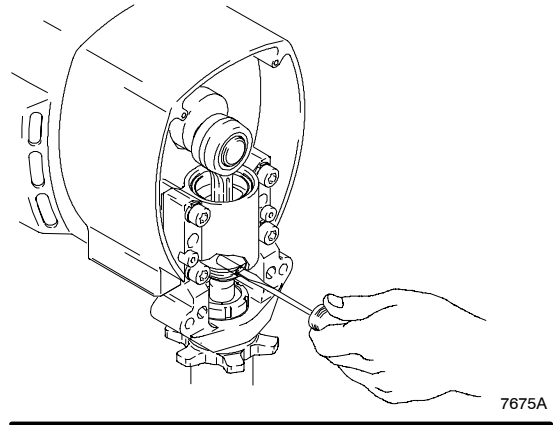

**Fig. 21**

# Service

Fig. 22. Reassemble intake valve with new o-ring (227), seat (212) and ball (214). Seat may be flipped over and used on other side. Clean seat thoroughly. Spring (236), for model 287946, is optional and not included with the pump.

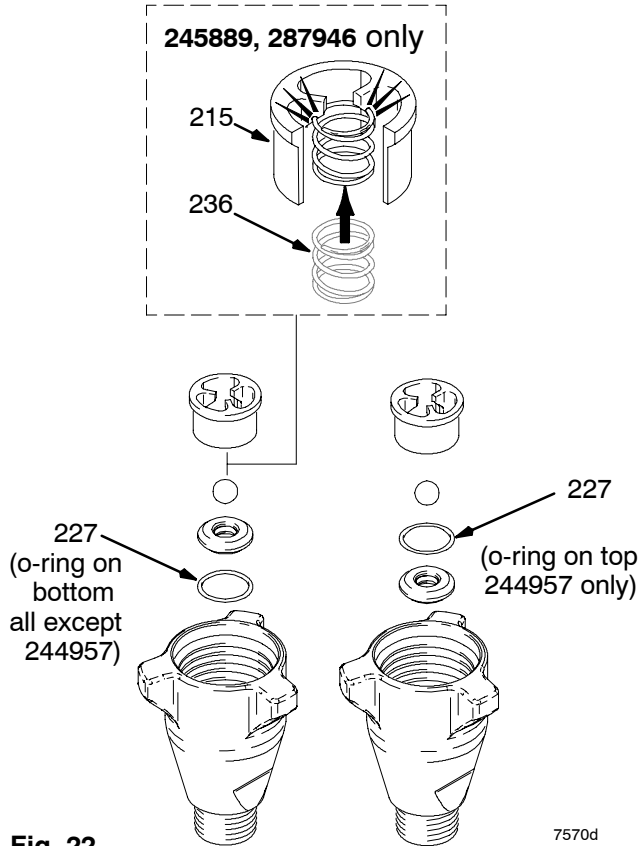
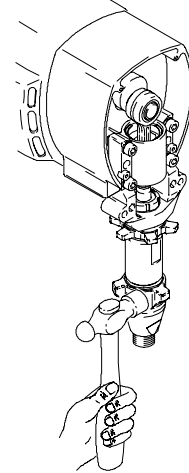

Fig. 23. Install intake valve on cylinder. Torque:  
67 +/-5 ft-lb (model 244197)  
80 +/-5 ft-lb (model 244224, 244201, 245904)  
200 +/-10 ft-lb (model 244954, 246257, 245889,  
287946, 244957, 248971, 248736, 277068, 287814,  
287815)



# Service

## Cross Sectional Reference

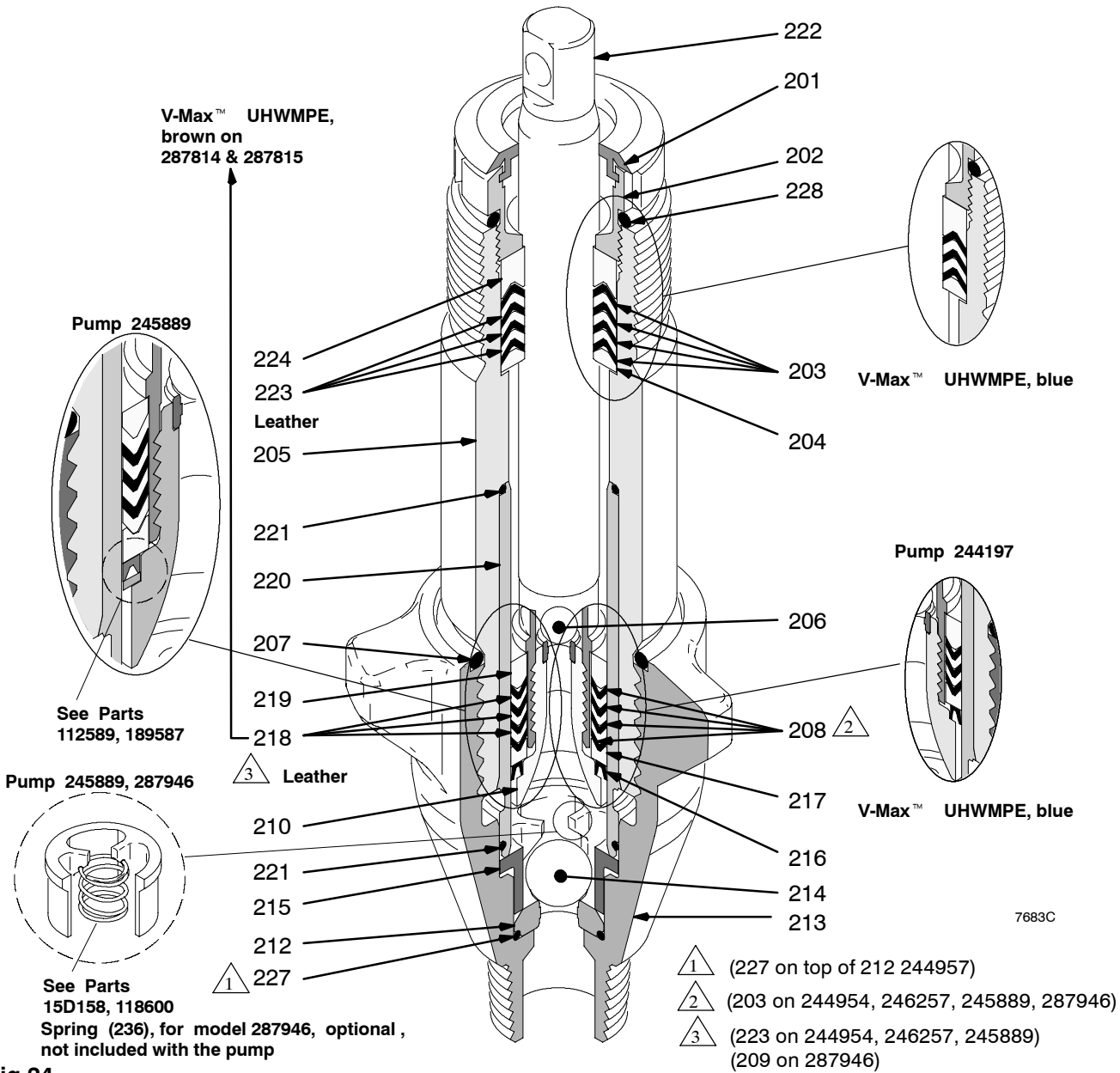

Fig 24

## Technical Data

### Maximum working pressure

All except 244957	3600 psi (250 bar, 24.8 MPa)
244957	4000 psi (276 bar, 27.6 MPa)

### Fluid inlet size

244224, 244197,	3/4 npt(m)
244201, 244954, 246257, 245889, 287946, 245904,	
248736, 248971, 287814, 287815	1 npsm(m)
244957	1-1/4 npt(m)

### Fluid outlet size

244197	1/4 npt(f)
244224, 244201, 244954, 246257, 245904, 248971	
248736, 287814, 287815	3/8 npt(f)
244957, 245889, 287946 (manifold)	1/2 npt(f)
Wetted parts	stainless steel, PTFE, leather, nylon, zinc-plated carbon steel, tungsten carbide, chrome plating, acetal, polyethylene

**NOTE:** Loctite® is a registered trademark of the Loctite Company.



# Parts - Pump 244197

## Model 244197, Series A

Ref No.	Part No.	Description	Qty.
201	179810	SEAL, throat	1
202	193046	NUT, packing	1
203*	192692	V-PACKING, throat, V-Max™ UHMWPE, blue	3
204*	178942	GLAND, male, throat	1
205	243346	CYLINDER, pump	1
206*	105444	BALL, sst, 0.3125 in.	1
207*	156593	PACKING, o-ring	1
208*	192693	V-PACKING, piston V-Max™ UHMWPE, blue	3
210	239932	VALVE, piston	1
212†	239922	KIT, seat, carbide includes 214 and 227	1
213	195892	VALVE, intake (foot)	1
214*†	105445	BALL, sst, 0.5000 in.	1
215	192624	GUIDE, ball	1
216*	196758	Guide, piston	1
217*	178969	GLAND, female, piston	1
218*	178939	V-PACKING, leather, piston	2
219*	196880	GLAND, male	1
220	240521	SLEEVE, cylinder	1
221*	108526	O-RING, PTFE	2
222*	248206	ROD, piston	1
223*	178940	V-PACKING, leather, throat	2
224*	178943	GLAND, female	1
225	196176	ADAPTER, nipple,	1
227*†	107079	PACKING, o-ring	1
228	158776	SPACER, throat adjustment o-ring	1

\* These parts are also included in Repair Kit 248212, which may be purchased separately.

† These parts are also included in Carbide Seat Kit 239922, which may be purchased separately.

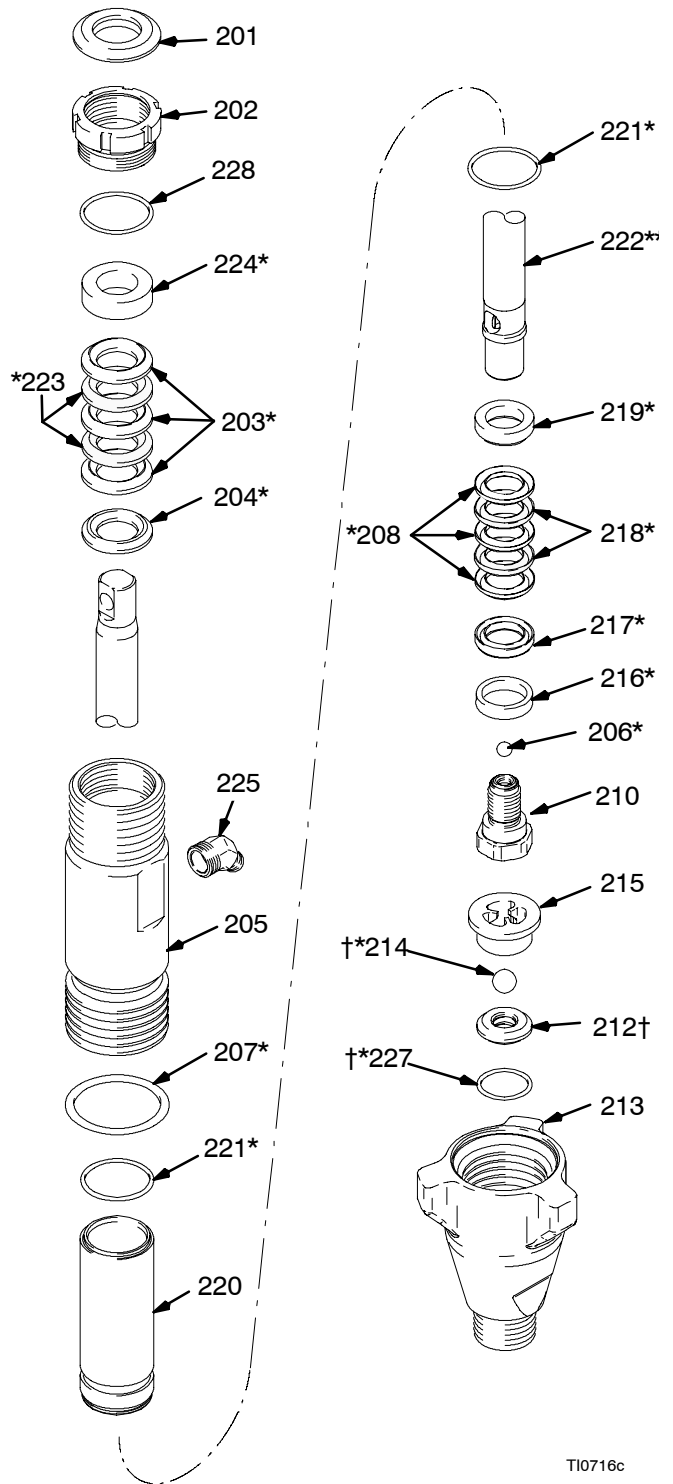

T10716c

# Parts - Pumps 244224, 244201, 245904

Models 244224, Series A; 244201, Series A; 245904, Series A

Ref No.	Part No.	Description	Qty.
201	183171	PLUG	1
202	193032	NUT, packing	1
203*	193124	V-PACKING V-Max™ UHMWPE, blue	4
204*	183176	GLAND, packing, male, throat	1
205	196754	Pump 244201, 245904	1
	243347	Pump 244224	1
206*	101947	BALL, sst, 0.375 in. Pump 244224, 244201	1
	116327	BALL, ceramic, 0.375 in. Pump 245904	1
207*	156633	PACKING, o-ring	1
208*	193125	V-PACKING, piston V-Max™ UHMWPE, blue	4
210	240150	VALVE, piston	1
212†	244199	SEAT, carbide (196866) Pump 244224, 244201 includes 214 and 227	1
	244571	SEAT, carbide (197470) Pump 245904 includes 214 and 227	1
213	196753	Pump 244201, 245904	1
	195894	Pump 244224	1
214*†	102972	BALL, sst, 0.875 in. Pump 244224, 244201	1
	111453	BALL, ceramic, 0.75 in. Pump 244409, 245904	1
215	193027	Pump 244224	1
	196967	Pump 244201, 245904	1
216*	196757	GUIDE, piston	1
217*	183185	GLAND, female, piston	1
218*	183174	V-PACKING, leather, piston	3
219*	183178	GLAND, packing, male	1
220	240525	SLEEVE, cylinder	1
221*	107098	PACKING, o-ring	2
222	241285	Pump 245904	1
	288479	Pump 244224	1
	241285	Pump 244201	1
223*	183175	V-PACKING, leather, throat	3
224*	183177	GLAND, packing, female	1
225	162485	NIPPLE, adapter, 3/8 npt x 3/8 npsm	1
227*†	108526	PACKING, o-ring	1
228	C20987	SPACER, throat adjustment o-ring	1

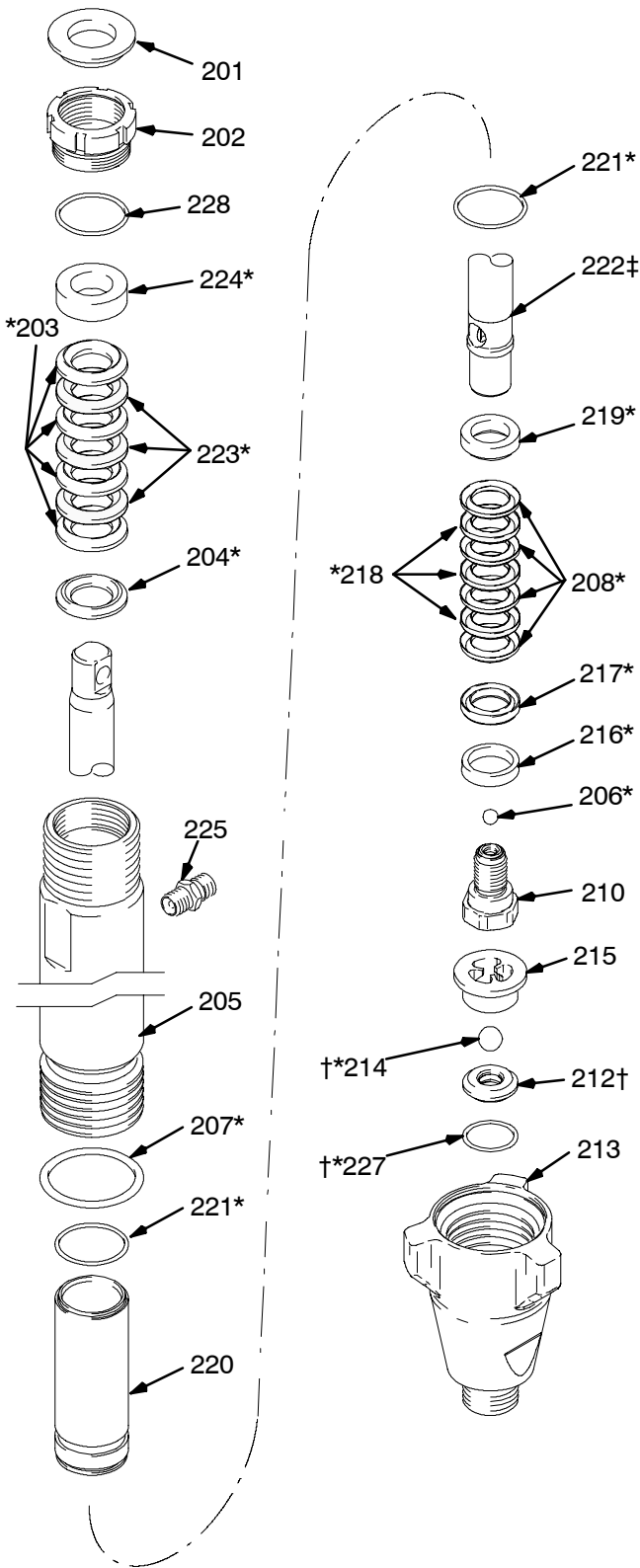

\* These parts are also included in Repair Kit 248213 (pump 244224, 244201) or Repair Kit 244200 (pump 245904), which may be purchased separately.

† These parts are also included in Carbide Seat Kit 244199 (pump 244224, 244201) or Carbide Seat Kit 244571 (pump 245904), which may be purchased separately.

T10717d

# Parts - Pump 244954

## Model 244954, Series A

Ref No.	Part No.	Description	Qty.
201	112590	PLUG	1
202	189589	NUT, packing	1
203*	198701	V-PACKING V-Max™ UHMWPE, blue	8
204*	198768	GLAND, packing, male, brass	1
205	244974	CYLINDER, pump	1
206*	107203	BALL, sst, 0.5625 in.	1
207*	160325	PACKING, o-ring	1
210	240580	VALVE, piston	1
212†	240918	SEAT, carbide includes 214 and 227	1
213	198121	HOUSING, intake (foot)	1
214*†	107167	BALL, sst, 1.000 in.	1
215	198505	GUIDE, ball	1
216*	198303	GUIDE, piston, plastic	1
217*	198765	GLAND, female, piston, steel	1
219	189585	GLAND, packing, male, steel	1
220	244975	SLEEVE, cylinder	1
221*	108822	PACKING, o-ring	2
222	287141	ROD, piston	1
223*	198718	V-PACKING, leather	6
224*	194175	GLAND, packing, female, brass	1
225	116756	NIPPLE, elbow, 45°	1
227*†	107098	PACKING, o-ring	1
228	157195	SPACER, throat adjustment o-ring	1
236	233698	SPRING, intake	1

\* These parts are also included in Repair Kit 246341, which may be purchased separately.

† These parts are also included in Carbide Seat Kit 240918, which may be purchased separately.

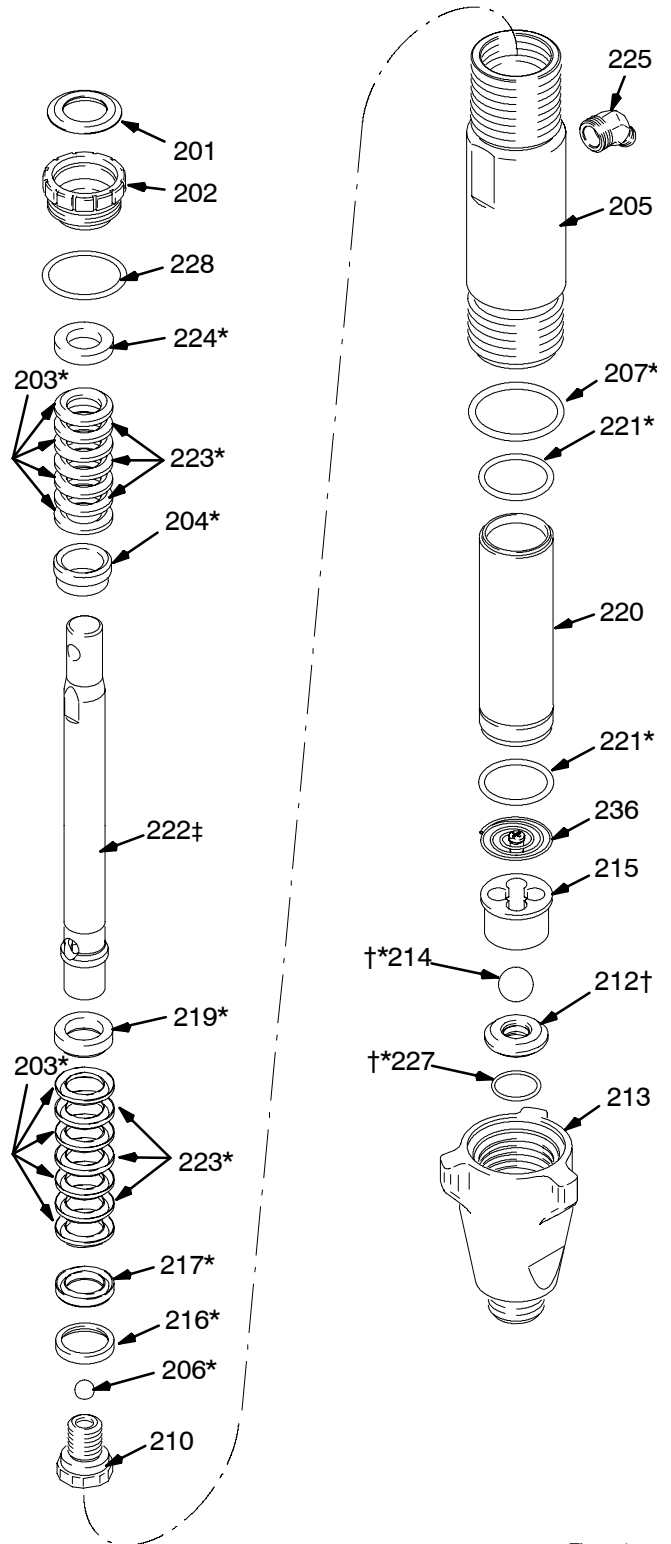

T11308d

# Parts - Pump 244957

## Model 244957, Series A

Ref No.	Part No.	Description	Qty.
201	196362	PLUG	1
202	196361	NUT, packing	1
203*	197468	V-PACKING (Throat) V-Max™ UHMWPE, blue	4
204 *	197372	GLAND, packing, male	2
205	244977	CYLINDER, pump	1
206*	101822	BALL, sst, 0.625 in.	1
207*	160258	PACKING, o-ring	1
208*	197469	V-PACKING (Piston) V-Max™ UHMWPE, blue	4
210	244454	VALVE, piston	1
212†	244960	SEAT, carbide includes 214 and 227	1
213	196357	HOUSING, intake (foot)	1
214*†	102973	BALL, sst, 1.25 in.	1
215	196363	GUIDE, ball	1
216*	196928	GUIDE, piston	1
217*	197354	GLAND, female, piston	1
218*	184305	V-PACKING, leather, piston	3
219*	196925	GLAND, packing, male	1
220	287557	SLEEVE, cylinder	1
221*	106259	PACKING, o-ring	2
222	287558	ROD, piston	1
223*	184304	V-PACKING, leather, throat	3
224*	197368	GLAND, packing, female	1
225	116755	NIPPLE, elbow, 45°	1
227*†	104537	PACKING, o-ring	1
228	160721	SPACER, throat adjustment o-ring	1

\* These parts are also included in Repair Kit 244958, which may be purchased separately.

† These parts are also included in Carbide Seat Kit 244960, which may be purchased separately.

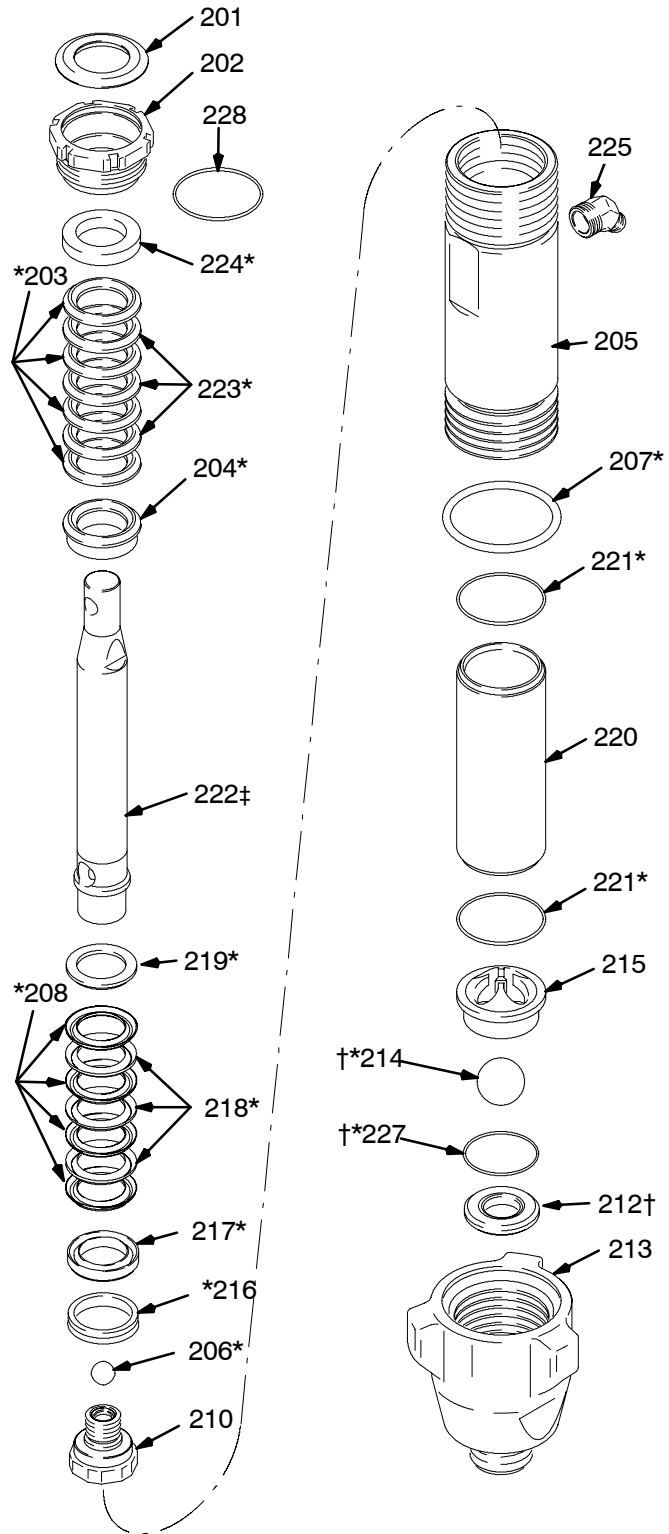

TI1317b

# Parts - Pump 245889

## Model 245889, Series B

Ref No.	Part No.	Description	Qty.
201	112590	PLUG	1
202	189589	NUT, packing	1
203*	198701	V-PACKING V-Max™ UHMWPE, blue	8
204*	198768	GLAND, male, throat, brass	1
205	245888	CYLINDER, pump	1
206	118601	BALL, ceramic, 0.5625 in.	1
207*	160325	PACKING, o-ring	1
210	240580	VALVE, piston	1
212†	245885	SEAT, carbide includes 214 and 227	1
213	15A303	HOUSING, intake (foot)	1
214†	118602	BALL, ceramic, 0.875 in.	1
215	15D158	GUIDE, ball	1
216*	112589	SEAL, U-cup	1
217*	198765	GLAND, female, piston, steel	1
219	189585	GLAND, packing, male, steel	1
220	240921	SLEEVE, cylinder	1
221*	108822	PACKING, o-ring	2
222	245886	ROD, piston	1
223*	198718	V-PACKING, leather, piston	6
224*	194175	GLAND, packing, female, brass	1
227*†	107098	PACKING, o-ring	1
228	157195	SPACER, throat adjustment o-ring	1
236	118600	SPRING, compression	1
237	189587	WASHER, back-up	1

\* These parts are also included in Repair Kit 245819, which may be purchased separately.

† These parts are also included in Carbide Seat Kit 245885, which may be purchased separately.

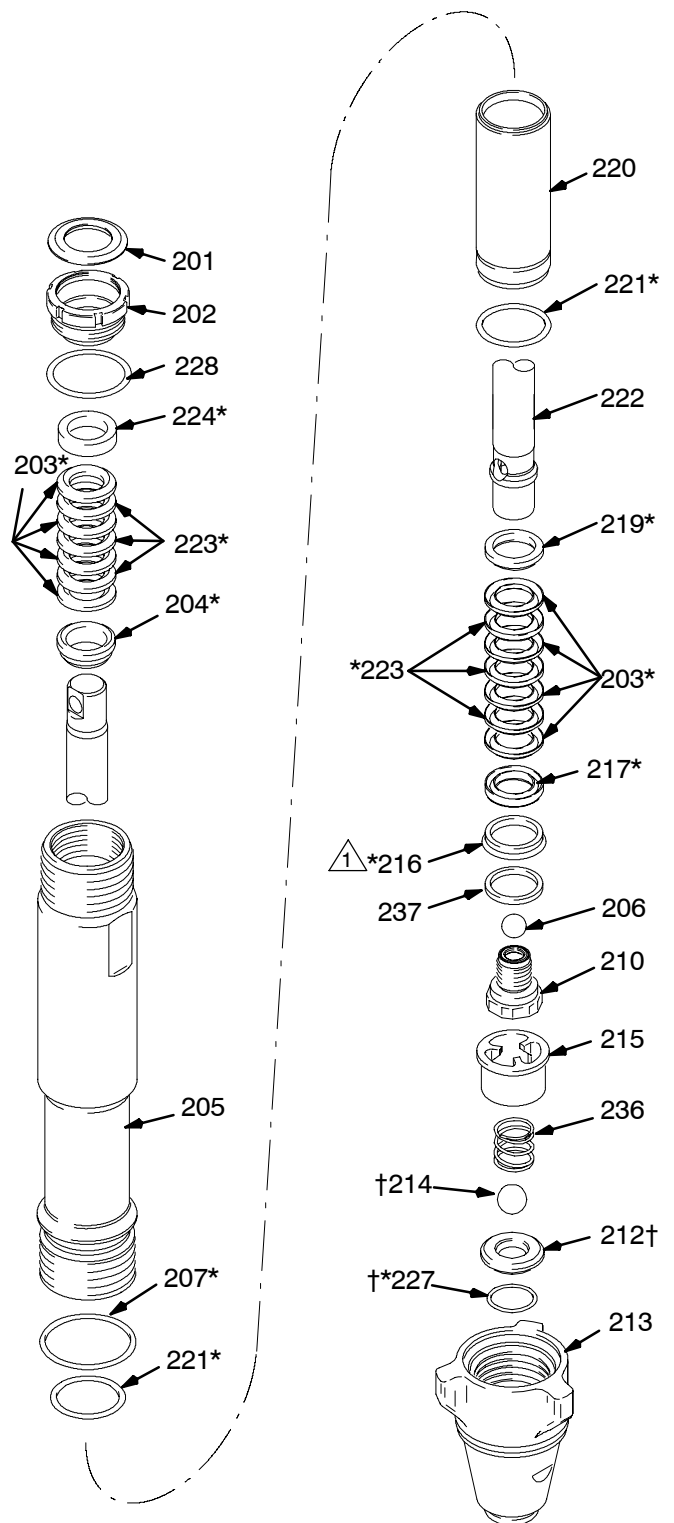

ti2086c

# Parts - Pump 287946

## Model 287946, Series A

Ref No.	Part No.	Description	Qty.
201	112590	PLUG	1
202	189589	NUT, packing	1
203*	198701	V-PACKING V-Max™ UHMWPE, blue	8
204*	198768	GLAND, male, throat, brass	1
205	15G437	CYLINDER, pump	1
206	118601	BALL, ceramic, 0.5625 in.	1
207*	160325	PACKING, o-ring	1
209*	112591	PACKING, vee, leather	3
210	249177	VALVE, piston	1
212†	245885	SEAT, carbide includes 214 and 227	1
213	15A303	HOUSING, intake (foot)	1
214†	118602	BALL, ceramic, 0.875 in.	1
215	15D158	GUIDE, ball	1
216*	119636	SEAL, U-cup	1
217*	189588	GLAND, female, piston, steel	1
219	189585	GLAND, packing, male, steel	1
220	248979	SLEEVE, cylinder	1
221*	108822	PACKING, o-ring	2
222	288103	ROD, piston	1
223*	198718	V-PACKING, leather, piston	3
224*	194175	GLAND, packing, female, brass	1
227*†	107098	PACKING, o-ring	1
228	157195	SPACER, throat adjustment o-ring	1
236	118600	SPRING, compression optional, not included with the pump	1
237	15F183	WASHER, back-up	1

\* These parts are also included in Repair Kit 287945, which may be purchased separately.

† These parts are also included in Carbide Seat Kit 245885, which may be purchased separately.

It is recommended that the check valve be repaired at the same time as the pump. See manual 313773 and Kit 258650.

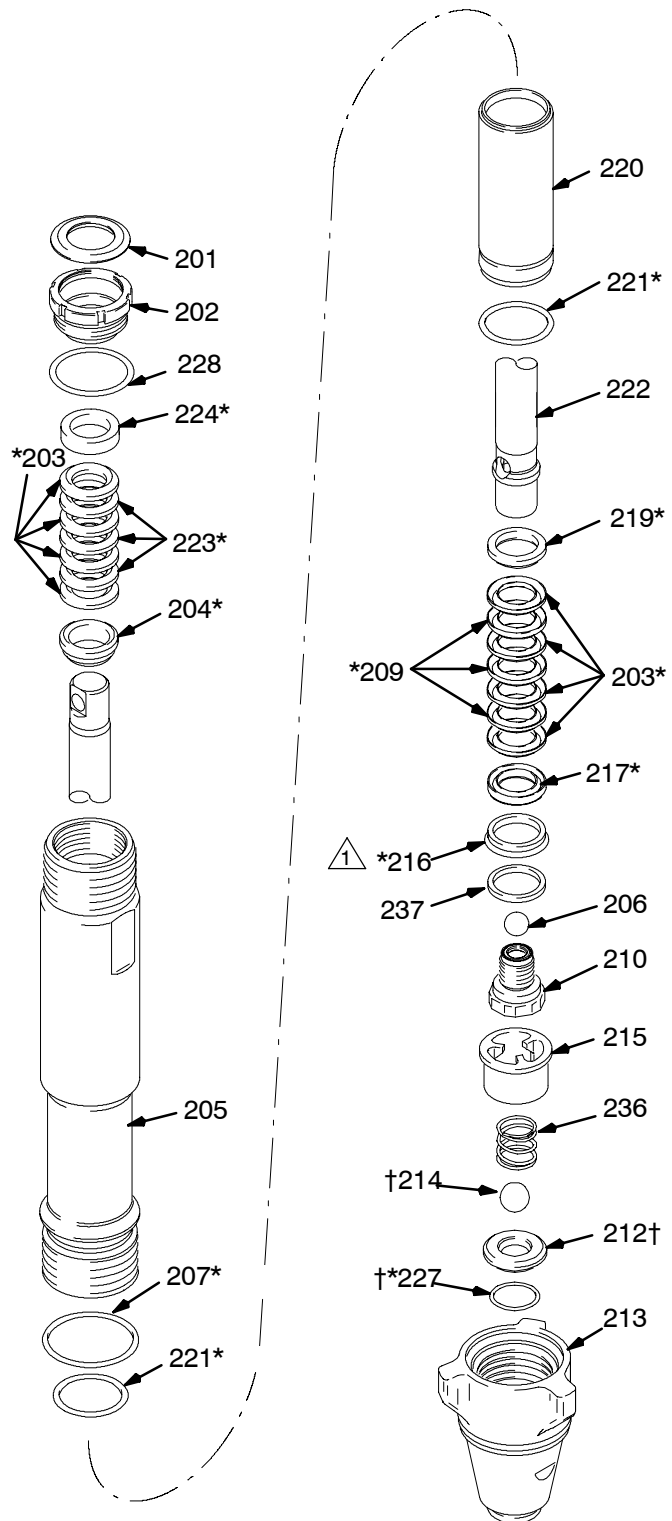

ti2086c

# Parts - Pump 246257

## Model 246257, Series A

Ref No.	Part No.	Description	Qty.
201	112590	PLUG	1
202	189589	NUT, packing	1
203*	198701	V-PACKING V-Max™ UHMWPE, blue	8
204*	198768	GLAND, male, throat, brass	1
205	245413	CYLINDER, pump	1
206*	107203	BALL, sst, 0.5625 in.	1
207*	160325	PACKING, o-ring	1
210	240580	VALVE, piston	1
212†	240918	SEAT, carbide includes 214 and 227	1
213	198219	HOUSING, intake (foot)	1
214*†	107167	BALL, sst, 1.000 in.	1
215	193391	GUIDE, ball	1
216*	198303	GUIDE, piston, plastic	1
217*	198765	GLAND, female, piston, steel	1
219	189585	GLAND, packing, male, steel	1
220	240921	SLEEVE, cylinder	1
221*	108822	PACKING, o-ring	2
222	249000	ROD, piston	1
223*	198718	V-PACKING, leather, piston	6
224*	194175	GLAND, packing, female, brass	1
227*†	107098	PACKING, o-ring	1
228	157195	SPACER, throat adjustment o-ring	1
236	233698	SPRING, intake	1

\* These parts are also included in Repair Kit 246341, which may be purchased separately.

† These parts are also included in Carbide Seat Kit 240918, which may be purchased separately.

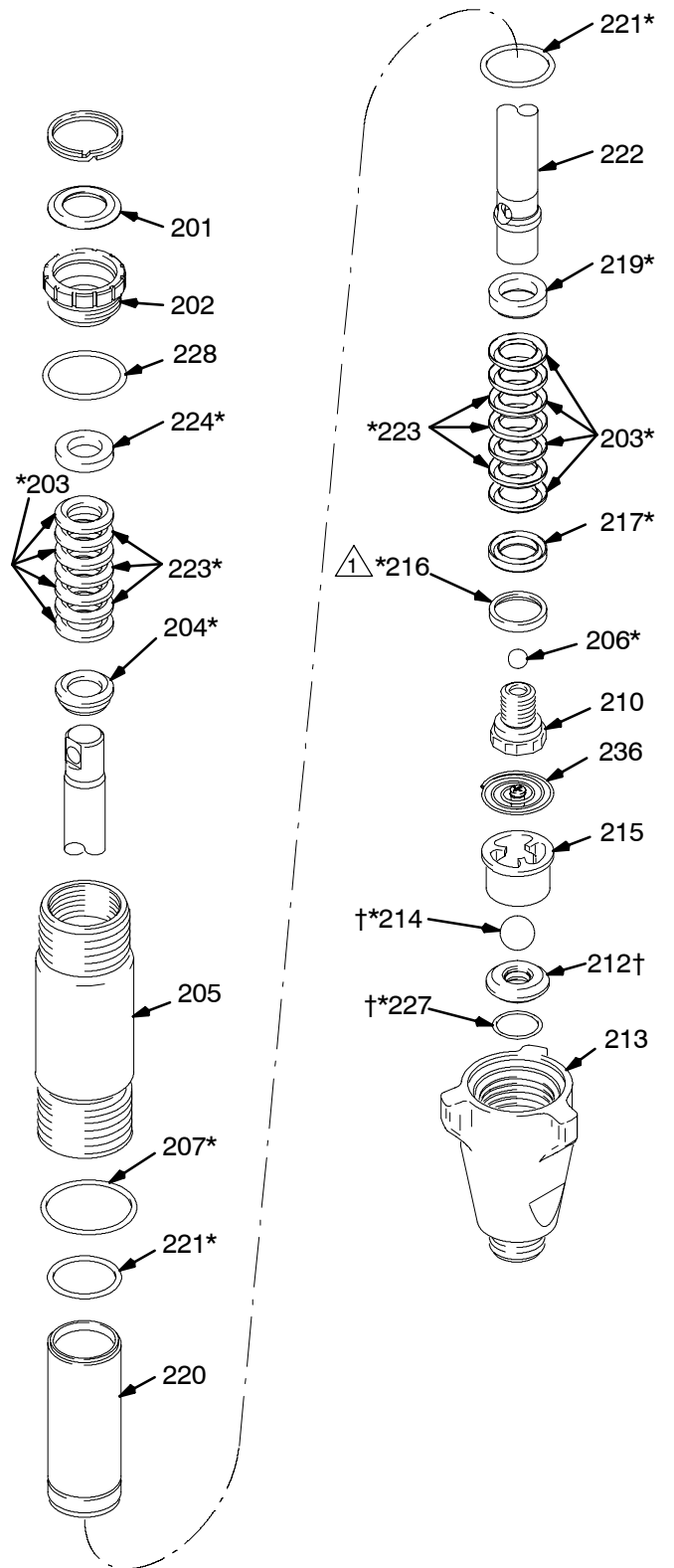

422212

# Parts - Pump 287815

## Model 287815, Series A

Ref No.	Part No.	Description	Qty.
201*	112590	PLUG	1
202	189589	NUT, packing	1
203*	198701	V-PACKING V-Max™ UHMWPE, blue	8
204*	15G658	GLAND, male, throat	1
205	249532	KIT, CYLINDER, pump	1
206*	107203	BALL, sst, 0.5625 in.	1
207*	160325	PACKING, o-ring	1
210	249177	VALVE, piston	1
212†	240918	SEAT, carbide includes 214 and 227	1
213	198219	HOUSING, intake (foot)	1
214*†	107167	BALL, sst, 1.000 in.	1
215	198505	GUIDE, ball	1
216*	119636	WIPER, piston	1
217*	189588	GLAND, female, piston, steel	1
219*	189585	GLAND, packing, male, steel	1
220	287817	SLEEVE, cylinder	1
221*	108822	PACKING, o-ring	2
222	287816	ROD, piston	1
223*	198718	V-PACKING, leather, piston	3
224*	15G657	GLAND, packing, female	1
227*†	107098	PACKING, o-ring	1
228*	157195	SPACER, throat adjustment o-ring	1
236	233698	SPRING, intake	1
237*	15F183	WASHER, backup	1
238*	15F875	V-PACKING, piston V-Max™ UHMWPE, brown	3

\* These parts are also included in Repair Kit 287813, which may be purchased separately.

† These parts are also included in Carbide Seat Kit 240918, which may be purchased separately.

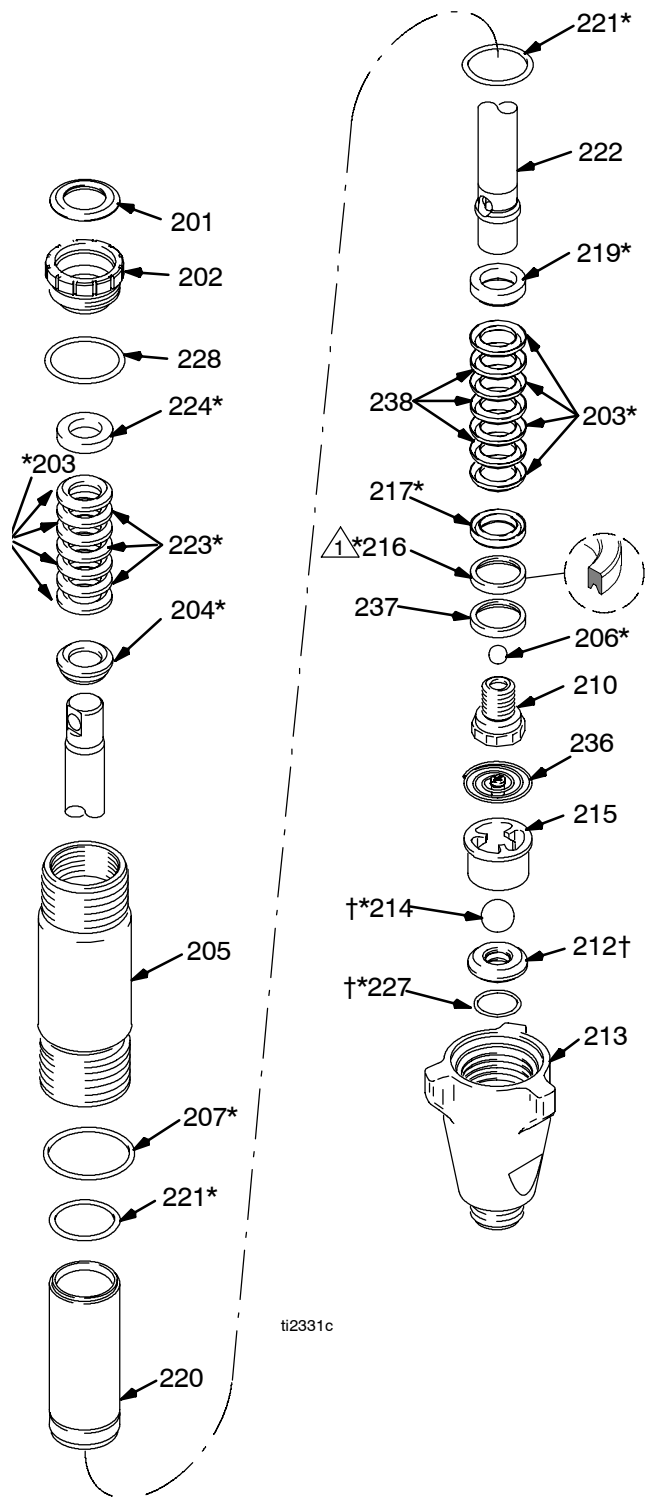

ti2331c



# Parts - Pump 287814

## Model 287814 Series A

Ref No.	Part No.	Description	Qty.
201*	112590	PLUG	1
202	189589	NUT, packing	1
203*	198701	V-PACKING V-Max™ UHMWPE, blue	8
204*	15G658	GLAND, male, throat	1
205	245413	CYLINDER, pump	1
206*	107203	BALL, sst, 0.5625 in.	1
207*	160325	PACKING, o-ring	1
210	249177	VALVE, piston	1
212†	240918	SEAT, carbide includes 214 and 227	1
213	198219	HOUSING, intake (foot)	1
214*†	107167	BALL, sst, 1.000 in.	1
215	198505	GUIDE, ball	1
216*	119636	WIPER, piston	1
217*	189588	GLAND, female, piston, steel	1
219*	189585	GLAND, packing, male, steel	1
220	249121	SLEEVE, cylinder	1
221*	108822	PACKING, o-ring	2
222	249119	ROD, piston	1
223*	198718	V-PACKING, leather, piston	3
224*	15G657	GLAND, packing, female	1
227*†	107098	PACKING, o-ring	1
228*	157195	SPACER, throat adjustment o-ring	1
236	233698	SPRING, intake	1
237*	15F183	WASHER, backup	1
238*	15F875	V-PACKING, piston V-Max™ UHMWPE, brown	3

\* These parts are also included in Repair Kit 287813, which may be purchased separately.

† These parts are also included in Carbide Seat Kit 240918, which may be purchased separately.

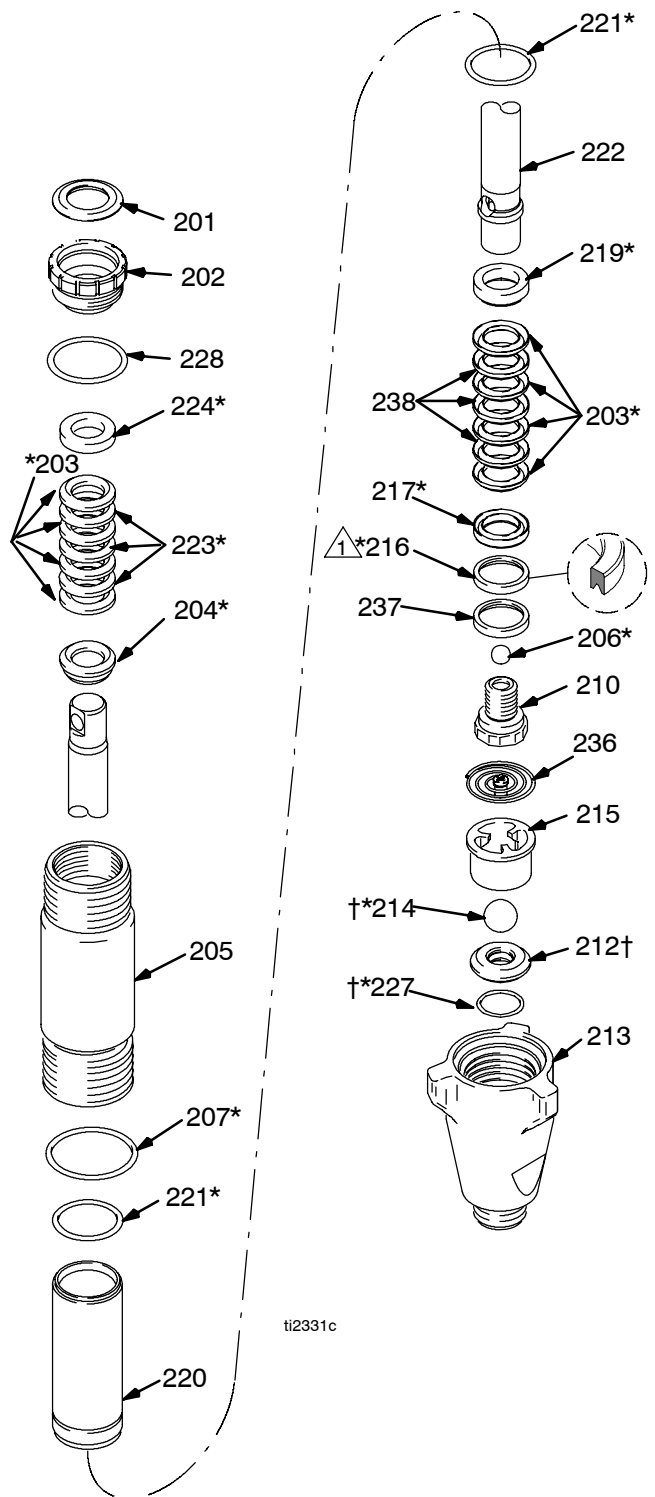

ti2331c

# Parts - Pump 248736

## Model 248736, Series A

Ref No.	Part No.	Description	Qty.
201	112590	PLUG	1
202	189589	NUT, packing	1
203*	198701	V-PACKING V-Max™ UHMWPE, blue	8
204*	198768	GLAND, male, throat, brass	1
205	249532	KIT, CYLINDER, pump	1
206*	107203	BALL, sst, 0.5625 in.	1
207*	160325	PACKING, o-ring	1
210	240580	VALVE, piston	1
212†	240918	SEAT, carbide includes 214 and 227	1
213	198219	HOUSING, intake (foot)	1
214*†	107167	BALL, sst, 1.000 in.	1
215	193391	GUIDE, ball	1
216*	198303	GUIDE, piston, plastic	1
217*	198765	GLAND, female, piston, steel	1
219	189585	GLAND, packing, male, steel	1
220	248980	SLEEVE, cylinder	1
221*	108822	PACKING, o-ring	2
222	249001	ROD, piston	1
223*	198718	V-PACKING, leather, piston	6
224*	194175	GLAND, packing, female, brass	1
227*†	107098	PACKING, o-ring	1
228	157195	SPACER, throat adjustment o-ring	1
236	233698	SPRING, intake	1

\* These parts are also included in Repair Kit 246341, which may be purchased separately.

† These parts are also included in Carbide Seat Kit 240918, which may be purchased separately.

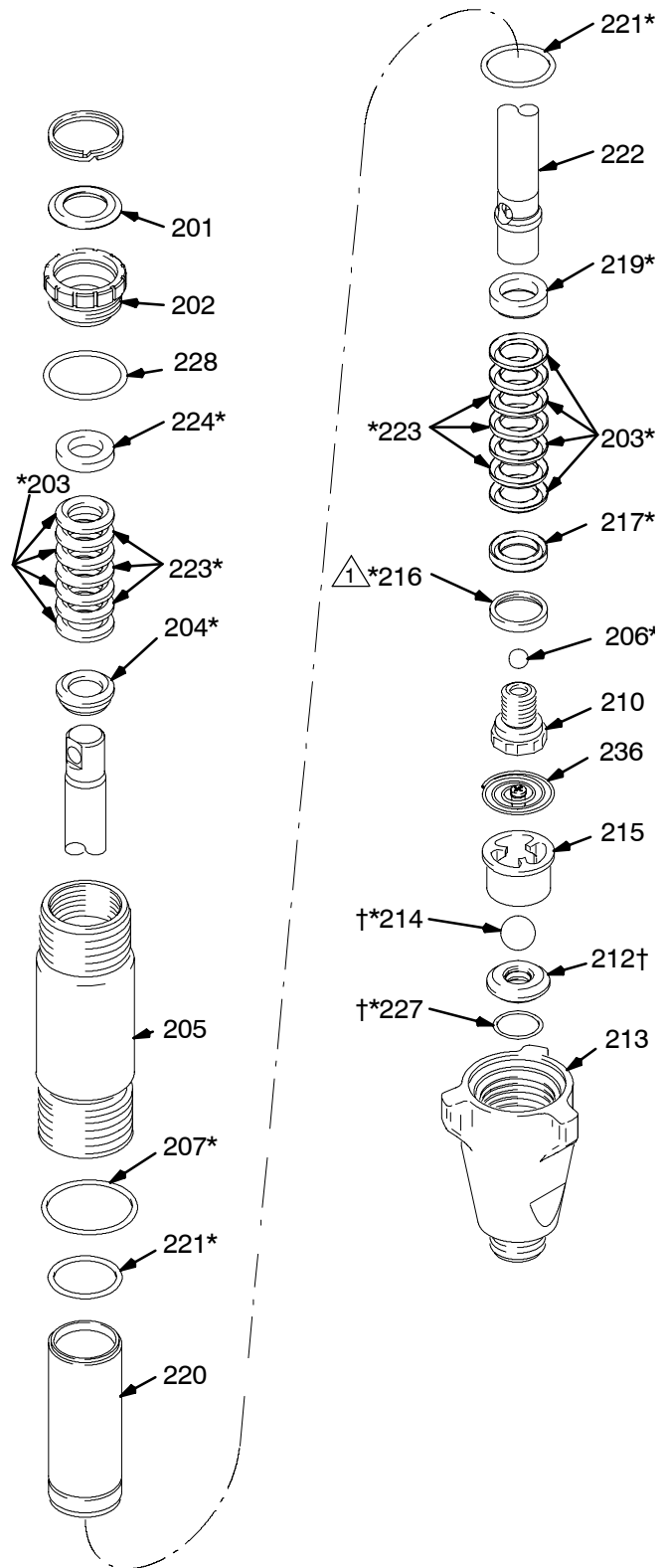

ti2331a

# Parts - Pump 248971, 277068

## Model 248971, Series A; 277068, Series A

Ref No.	Part No.	Description	Qty.
201	112590	PLUG	1
202	189589	NUT, packing	1
203*	198701	V-PACKING V-Max™ UHMWPE, blue	8
204*	198768	GLAND, male, throat, brass	1
205	245413	CYLINDER, pump	1
206*	107203	BALL, sst, 0.5625 in.	1
207*	160325	PACKING, o-ring	1
210	240580	VALVE, piston	1
212†	240918	SEAT, carbide includes 214 and 227	1
213	198219	HOUSING, intake (foot)	1
214*†	107167	BALL, sst, 1.000 in.	1
215	193391	GUIDE, ball	1
216*	198303	GUIDE, piston, plastic	1
217*	198765	GLAND, female, piston, steel	1
219	189585	GLAND, packing, male, steel	1
220	248979	PUMP, 248971	1
	240921	PUMP, 277068	1
221*	108822	PACKING, o-ring	2
222	249000	ROD, piston	1
223*	198718	V-PACKING, leather, piston	6
224*	194175	GLAND, packing, female, brass	1
227*†	107098	PACKING, o-ring	1
228	157195	SPACER, throat adjustment o-ring	1
236	233698	SPRING, intake	1

\* These parts are also included in Repair Kit 246341, which may be purchased separately.

† These parts are also included in Carbide Seat Kit 240918, which may be purchased separately.

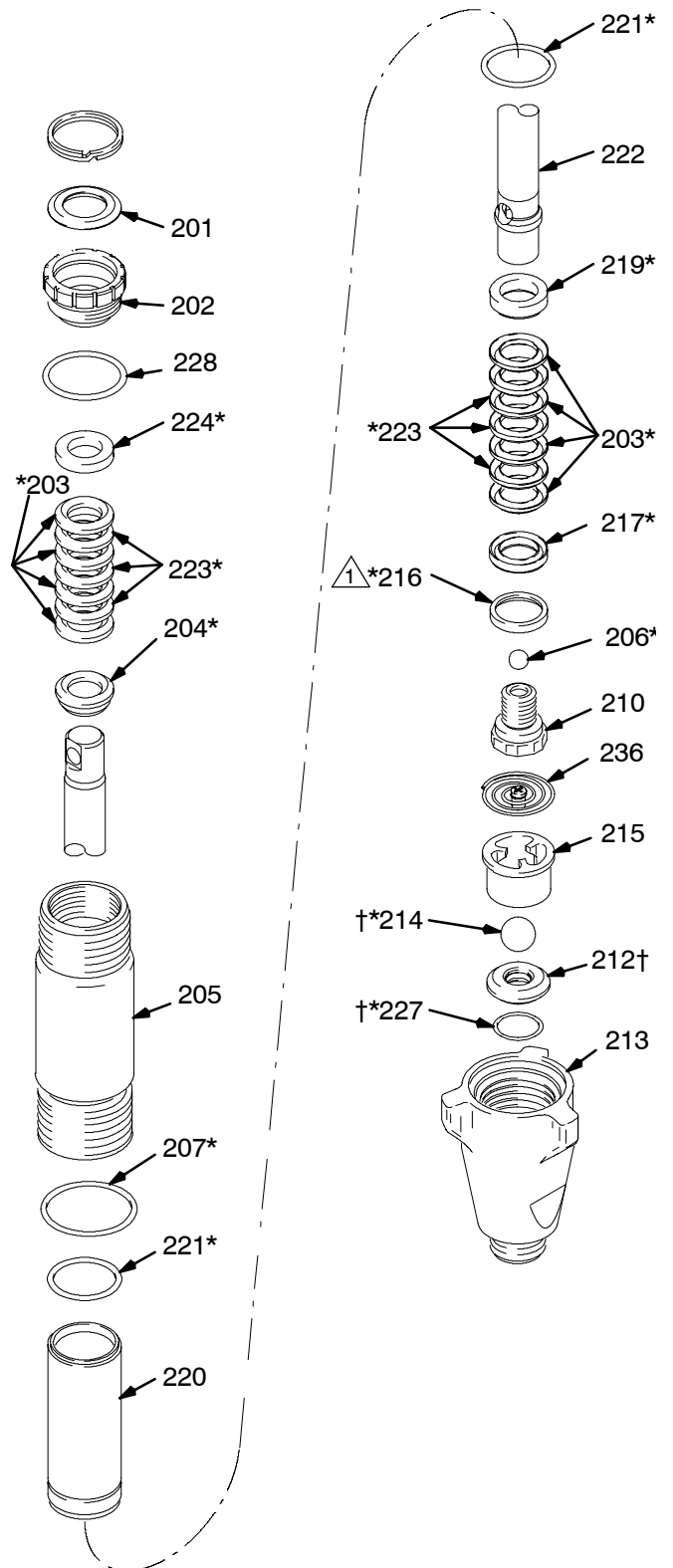

ti2331a

# Graco Standard Warranty

Graco warrants all equipment referenced in this document which is manufactured by Graco and bearing its name to be free from defects in material and workmanship on the date of sale to the original purchaser for use. With the exception of any special, extended, or limited warranty published by Graco, Graco will, for a period of twelve months from the date of sale, repair or replace any part of the equipment determined by Graco to be defective. This warranty applies only when the equipment is installed, operated and maintained in accordance with Graco's written recommendations.

This warranty does not cover, and Graco shall not be liable for general wear and tear, or any malfunction, damage or wear caused by faulty installation, misapplication, abrasion, corrosion, inadequate or improper maintenance, negligence, accident, tampering, or substitution of non-Graco component parts. Nor shall Graco be liable for malfunction, damage or wear caused by the incompatibility of Graco equipment with structures, accessories, equipment or materials not supplied by Graco, or the improper design, manufacture, installation, operation or maintenance of structures, accessories, equipment or materials not supplied by Graco.

This warranty is conditioned upon the prepaid return of the equipment claimed to be defective to an authorized Graco distributor for verification of the claimed defect. If the claimed defect is verified, Graco will repair or replace free of charge any defective parts. The equipment will be returned to the original purchaser transportation prepaid. If inspection of the equipment does not disclose any defect in material or workmanship, repairs will be made at a reasonable charge, which charges may include the costs of parts, labor, and transportation.

**THIS WARRANTY IS EXCLUSIVE, AND IS IN LIEU OF ANY OTHER WARRANTIES, EXPRESS OR IMPLIED, INCLUDING BUT NOT LIMITED TO WARRANTY OF MERCHANTABILITY OR WARRANTY OF FITNESS FOR A PARTICULAR PURPOSE.**

Graco's sole obligation and buyer's sole remedy for any breach of warranty shall be as set forth above. The buyer agrees that no other remedy (including, but not limited to, incidental or consequential damages for lost profits, lost sales, injury to person or property, or any other incidental or consequential loss) shall be available. Any action for breach of warranty must be brought within two (2) years of the date of sale.

**GRACO MAKES NO WARRANTY, AND DISCLAIMS ALL IMPLIED WARRANTIES OF MERCHANTABILITY AND FITNESS FOR A PARTICULAR PURPOSE, IN CONNECTION WITH ACCESSORIES, EQUIPMENT, MATERIALS OR COMPONENTS SOLD BUT NOT MANUFACTURED BY GRACO.** These items sold, but not manufactured by Graco (such as electric motors, switches, hose, etc.), are subject to the warranty, if any, of their manufacturer. Graco will provide purchaser with reasonable assistance in making any claim for breach of these warranties.

In no event will Graco be liable for indirect, incidental, special or consequential damages resulting from Graco supplying equipment hereunder, or the furnishing, performance, or use of any products or other goods sold hereto, whether due to a breach of contract, breach of warranty, the negligence of Graco, or otherwise.

## **FOR GRACO CANADA CUSTOMERS**

The parties acknowledge that they have required that the present document, as well as all documents, notices and legal proceedings entered into, given or instituted pursuant hereto or relating directly or indirectly hereto, be drawn up in English. Les parties reconnaissent avoir convenu que la rédaction du présente document sera en Anglais, ainsi que tous documents, avis et procédures judiciaires exécutés, donnés ou intentés à la suite de ou en rapport, directement ou indirectement, avec les procédures concernées.

## **ADDITIONAL WARRANTY COVERAGE**

Graco does provide extended warranty and wear warranty for products described in the "Graco Contractor Equipment Warranty Program".

**TO PLACE AN ORDER**, contact your Graco distributor, or call this number to identify the distributor closest to you:  
**1-800-690-2894 Toll Free**

*All written and visual data contained in this document reflect the latest product information available at the time of publication.  
Graco reserves the right to make changes at any time without notice.*

This manual contains English; MM 309277

**Graco Headquarters:** Minneapolis  
**International Offices:** Belgium, China, Japan, Korea  
**GRACO INC. P.O. BOX 1441 MINNEAPOLIS, MN 55440-1441**  
www.graco.com  
10/2000, Rev. 05/2009