

Pulse Count Kits 24B796 and 24B798

406824B

Husky[®] 1050 Diaphragm Pumps

ENG

Kit 24B796

for pumps with a polypropylene or conductive polypropylene center section and air valve.

Kit 24B798

for pumps with an aluminum center section and air valve.



Important Safety Instructions

Read all warnings and instructions in the Husky[®] 1050 Air-Operated Diaphragm Pump Repair/Parts manual. Save all instructions.

Ref.	Description	Qty.
101	REED SWITCH ASSEMBLY	1
102	SCREW	1

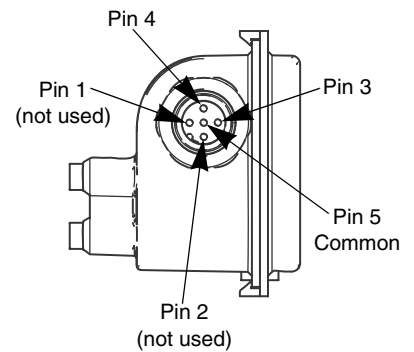
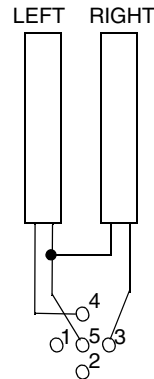
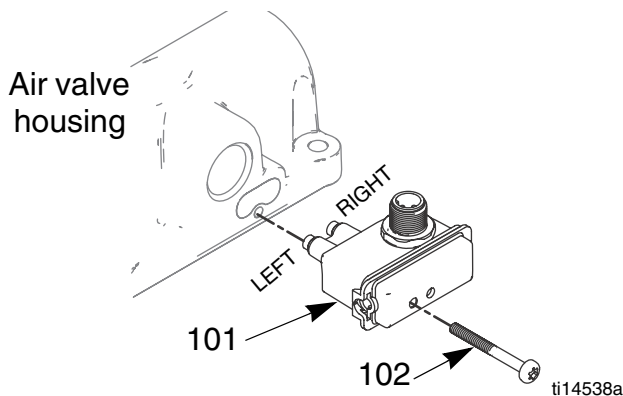

ti14539a

See Instructions on reverse.

Graco Inc. P.O. Box 1441 Minneapolis, MN 55440-1441
406824 Rev, B 12/2009
Copyright 2009, Graco Inc. is registered to ISO 9001

Installation

Use these kits with customer-supplied fluid management or inventory tracking systems. Each kit includes a module with two reed switches and a mounting screw.

1. Attach the reed switch module to the air valve of a Husky 1050 AODD pump.
2. Attach an M12, 5-pin female connector (customer supplied) to the reed switch to interface with customer wiring. See illustration on front.

When properly connected, the reed switches detect the position of the air valve. Each reed switch is momentary and closes only when near the air valve magnet. The right reed switch is closed when the air valve is in the right position, and the left reed switch is closed when the air valve is in the let position. When a reed switch is opened then closed, or closed then opened, one complete pump cycle has occurred.

When connecting, note that either reed switch can detect one complete pump cycle. Both can be used, however, to detect half-cycles for greater precision or for system redundancy.

Specifications

Type	Normally open
Maximum power.....	10 W
Maximum voltage.....	170 VDC
Initial contact resistance (Maximum)	0.2 Ohms
Contact Capacitance (Typical)	0.2 pF