

# Air Valve Seal Kits

406813B

Husky® 1050 Diaphragm Pumps

ENG

## Kits 24B769 and 24C983

Ref.	Description	Qty.	Ref.	Description	Qty.
101	O-RINGS, end cap	2	104	O-RING, for Kit 24B769 (used for DataTrak models with runaway protection)	1
102	U-CUPS, piston	2	105	GASKET, air valve (not shown)	1
103	SCREW	2	106	GREASE, lithium-based (not shown)	1
Kit 24B769: M3 (shorter - for metal pumps) and #4 (longer - for plastic pumps) Kit 24C983: M3					

See reverse for assembly directions.

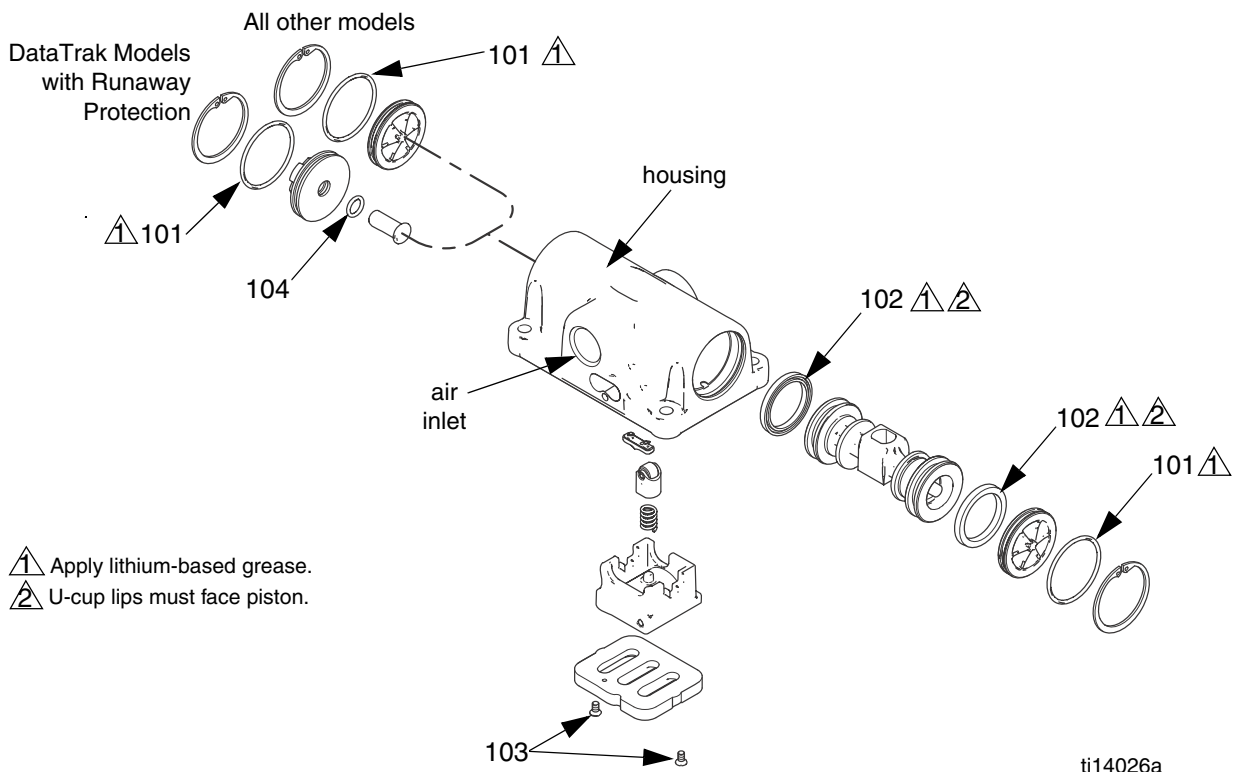

## Assembly

**NOTE:** Apply lithium-based grease whenever instructed to grease.

1. Use all parts in the repair kits, as applicable to your pump. Clean other parts and inspect for damage. Replace as needed.
2. Grease the detent cam and install into housing.
3. Grease the u-cups (102) and install on the piston with lips facing toward the center of the piston.
4. Grease both ends of the piston and install it in the housing. Be careful not to tear u-cup (102) when sliding piston into housing.
5. **Standard or Pulse Count models (no runaway protection solenoid):** Grease new o-rings (101) and install on the end caps. Install the end caps into the housing.  
**DataTrak models (with runaway protection solenoid):** Orient the air valve so the air inlet faces forward. Grease and install new o-ring (101) on right-side end cap. Grease and install new o-ring (101) and the solenoid release button and o-ring (104) on left-side end cap. Install the end caps into the housing.
6. Install a retaining ring on each end to hold end caps in place.
7. Grease and install the detent assembly into the piston. Install the spring. Grease the side of the air valve cup that will contact the valve plate. Install the air valve cup. Align the small round magnet with the air inlet.
8. Install the valve plate. Align the small hole in the plate with the air inlet. Tighten the screws (103) to hold it in place.