

Overmolded Diaphragm Kits 24B625 and 24B626

Husky® 1050 Diaphragm Pumps

406808A



Important Safety Instructions

Read all warnings and instructions in the Husky® 1050 Air-Operated Diaphragm Pump Repair/Parts manual. Save all instructions.

Kit 24B625, Neoprene®
Kit 24B626, PTFE

Ref.	Description	Qty.
101	DIAPHRAGM, material shown at left	2
102	SETSCREW, stainless steel	2
104	TOOL, diaphragm install	1
105	O-RING, manifold, PTFE (not shown)	8

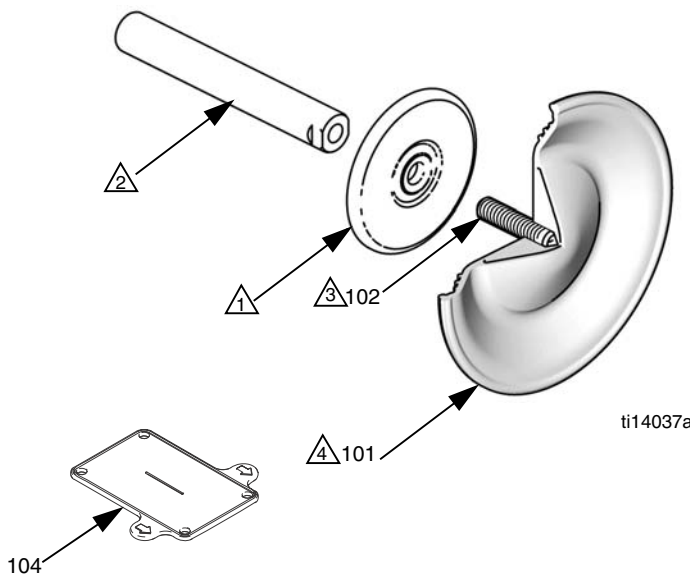

- ① Rounded side faces diaphragm.
- ② Apply lithium-based grease.
- ③ Apply permanent (red) Loctite® or equivalent to diaphragm side threads (if screw was removed or replaced). Apply primer and medium-strength (blue) Loctite® or equivalent to shaft side threads. Screw into shaft hand-tight.
- ④ AIR SIDE markings on diaphragm must face center housing.

Graco Inc. P.O. Box 1441 Minneapolis, MN 55440-1441
 406808 Rev, A 08/2009
 Copyright 2009, Graco Inc. is registered to ISO 9001

See reverse for assembly instructions.

Assembly

1. Clamp the shaft flats in a vise.
2. Assemble the air side plate onto the diaphragm. The rounded side of the plate must face the diaphragm.
3. Apply medium-strength (blue) Loctite or equivalent to the threads of the diaphragm assembly. Screw the assembly into the shaft as tight as possible by hand.
4. Apply lithium-based grease to the shaft u-cups (in center housing) and the length and ends of the diaphragm shaft. Slide the shaft into the housing.
5. Reattach the first fluid cover. Follow **Torque Instructions** in the manual.
6. Repeat Steps 2 and 3 for the other diaphragm assembly.
7. To ensure proper seating and extend diaphragm life, attach the second fluid cover with air pressure on the pump.
 - a. Place the supplied tool (104) where the air valve gasket normally goes. Arrows (A) must face toward the fluid cover that is already attached.
 - b. Reattach the air valve.
 - c. Supply a minimum of 20 psi (0.14 MPa, 1.4 bar) air pressure to the air valve. Shop air may be used. The diaphragm will shift so the second fluid cover will seat properly. Keep air pressure on until the second fluid cover is attached.
 - d. Attach the second fluid cover. Follow **Torque Instructions** in the manual.
 - e. Remove the air valve and the tool (104), replace the gasket, and reattach the air valve. Follow **Torque Instructions** in the manual.
8. Reassemble the ball check valves and manifolds as explained in the manual.

NOTE: If you are replacing the diaphragms but not the air valve, you must remove the air valve and gasket, put the tool in place of the gasket, and put the air valve back on to get the air pressure needed for proper installation of the second fluid cover. Remember to remove the tool and replace the gasket when finished.

