

Slide Valve Kit 257782 for AA30 Air Assisted Spray Gun

313609A



- This manual contains kit installation instructions only -



Important Safety Instructions

For detailed sprayer information and warnings, see Operation manual 313316 included with FinishPro 290 Sprayer.

Pressure Relief Procedure

						
<p>To help prevent injection injuries, follow this procedure when you stop spraying and before you service or clean the sprayer, remove parts, or repair leaks.</p>						

1. Turn Power switch OFF. Unplug sprayer.
2. Turn Spray/Prime valve to PRIME to relieve pressure. Turn pressure control knob left (counterclockwise) to minimize pressure.

3. Trigger gun.

4. Put trigger safety in safety ON position.

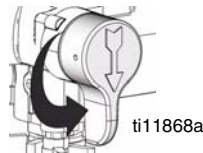

NOTE: Leave Spray/Prime valve in the PRIME position until you are ready to spray again.

If you suspect that the spray tip or hose is completely clogged or that pressure has not been fully relieved after following the steps above, VERY SLOWLY loosen the tip guard retaining nut or hose end coupling to relieve pressure gradually. Then loosen it completely. Clear the tip or hose obstruction.

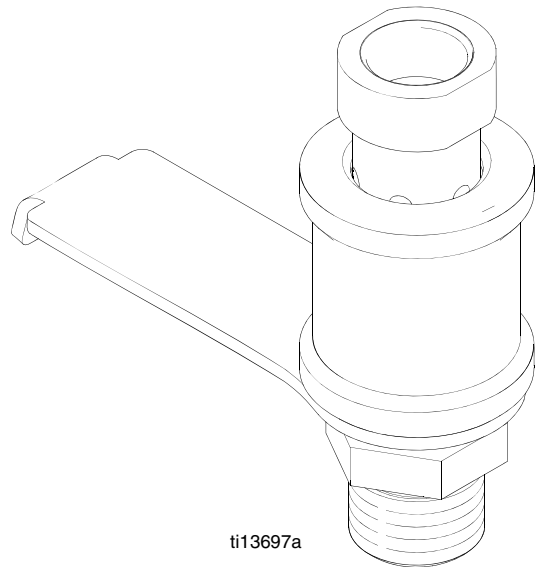

Slide Valve Kit 257782

Installation

1. Relieve pressure. Set trigger lock (11a).
2. Disconnect air hose from gun.
3. Disconnect bracket (36) from retainer (16) and swivel out of the way.
4. Place a wrench on the flats of the slide valve body and on the air tube nut and remove the slide valve.
5. Place gasket (G) into new slide valve assembly (V).
6. Tighten slide valve assembly (V) to the air tube nut. Torque to 150-160 in-lb (15-18 N•m).
7. Connect bracket (36) to retainer (16).
8. Connect air hose back into gun.

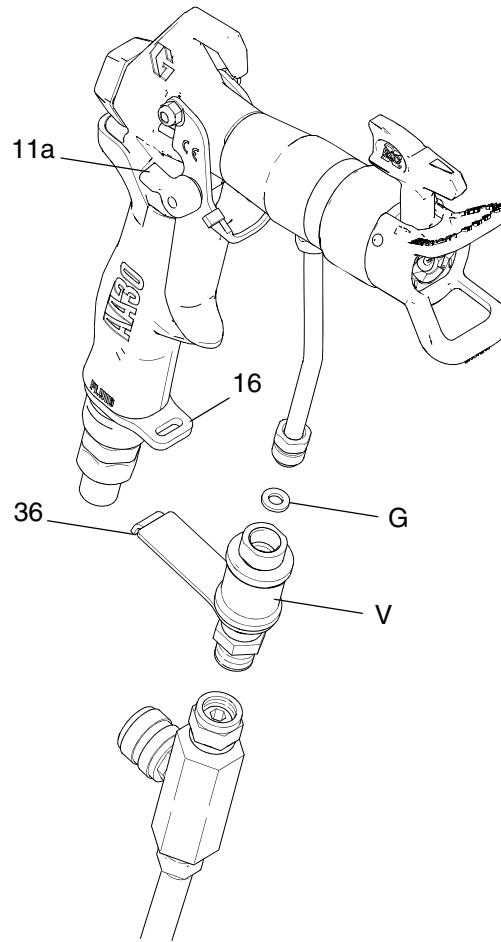

*All written and visual data contained in this document reflects the latest product information available at the time of publication.
Graco reserves the right to make changes at any time without notice.*

This manual contains English. MM 313609

Graco Headquarters: Minneapolis
International Offices: Belgium, China, Japan, Korea

GRACO INC. P.O. BOX 1441 MINNEAPOLIS, MN 55440-1441

Copyright 2009, Graco Inc. is registered to ISO 9001

www.graco.com