

Belt-Drive Pressure Washers

309732F

Models:

3040 - 246454, Series A

3000 psi (20.7 MPa, 207 bar) Maximum Working Pressure

3540 - 246455, Series A

3500 psi (24.1 MPa, 241 bar) Maximum Working Pressure



Important Safety Instructions

Read all warnings and instructions in this manual.
Save these instructions.

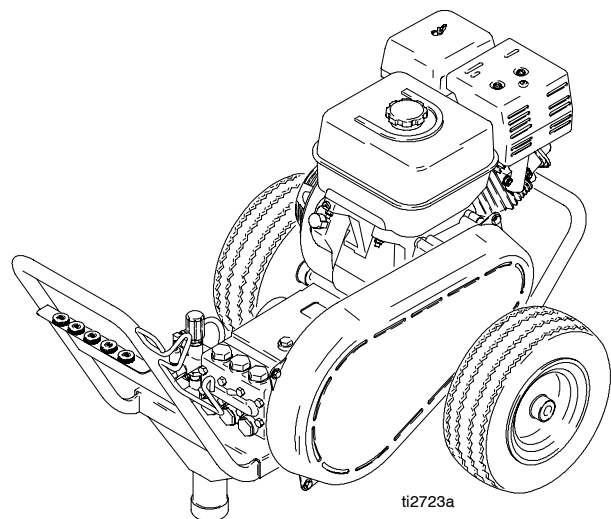

**3040 Pressure Washer
Model 246454**

PROVEN QUALITY. LEADING TECHNOLOGY.

GRACO INC. P.O. BOX 1441 MINNEAPOLIS, MN 55440-1441

Copyright 2002, Graco Inc. is registered to I.S. EN ISO 9001



H003

Table of Contents

Warnings	2	Pressure Washer Parts Drawing and List	12
Setup	4	Pump Parts Drawing and List	14
Operation	5	Troubleshooting	16
Pressure Relief Procedure	5	Technical Data	17
Pump Service	10	Graco Standard Warranty	18
		Graco Phone Number	18

Symbols

Warning Symbol



This symbol alerts you to the possibility of serious injury or death if you do not follow the instructions.

Caution Symbol



This symbol alerts you to the possibility of damage to or destruction of equipment if you do not follow the instructions.

! WARNING



INJECTION HAZARD

Spray from the gun, leaks or ruptured components can inject fluid into your body and cause serious injury. Fluid splashed in the eyes or on the skin can also cause serious injury.

- Fluid injected into the skin may look like just a cut, but it is a serious injury. **Get emergency surgical attention.**
- Do not point the gun at anyone or at any part of the body.
- Do not stop or deflect leaks with hand, body, glove, or rag.
- Do not put your hand or fingers over the spray tip.
- Tighten fluid connections before you start this equipment.
- Engage the gun trigger safety when you stop spraying.
- Follow **Pressure Relief Procedure** on page 5 if the spray tip clogs and before you clean, check, or service this equipment.
- Repair or replace worn or damaged parts immediately.
- Check hoses, tubes, and couplings daily. Do not repair high-pressure couplings; you must replace the entire hose. Fluid hoses must have spring guards on both ends to prevent kinks and rupture.

WARNING



MOVING PARTS HAZARD

Moving parts, such as the drive belt, can pinch or amputate fingers.

- Keep clear of moving parts when you start or operate this equipment.
- Do not operate the pressure washer without all guards and interlocks installed and functioning.



HAZARDOUS FLUIDS

Improper handling of hazardous fluids can cause serious injury or death from splashing in the eyes, ingestion, or bodily contamination.

- Know the specific hazards of the fluid being used.
- Store hazardous fluids in approved containers. Dispose of hazardous fluids per local, state, and national guidelines.
- Wear protective eye wear, gloves, clothing, and respirator as recommended by the fluid and solvent manufacturer.



FUEL HAZARD

The fuel used in this pressure washer is combustible. When spilled on a hot surface, it can ignite and cause a fire.

Do not fill the fuel tank while the engine is running or hot.



EXHAUST HAZARD

The exhaust contains poisonous carbon monoxide, which is colorless and odorless.

Do not operate this equipment in a closed building.



EQUIPMENT MISUSE HAZARD

Misuse of the pressure washer or accessories may cause them to rupture and result in fluid injection, splashing in the eyes or on the skin, or other serious injury.

- Do not alter or modify any part or factory-set adjustment of this equipment.
- Do not exceed the maximum working pressure of any component or accessory in the system.
- Do not use any chemicals that are incompatible with the wetted parts as stated in the **Technical Data** on page 17.
- Do not alter the throttle setting.

Setup

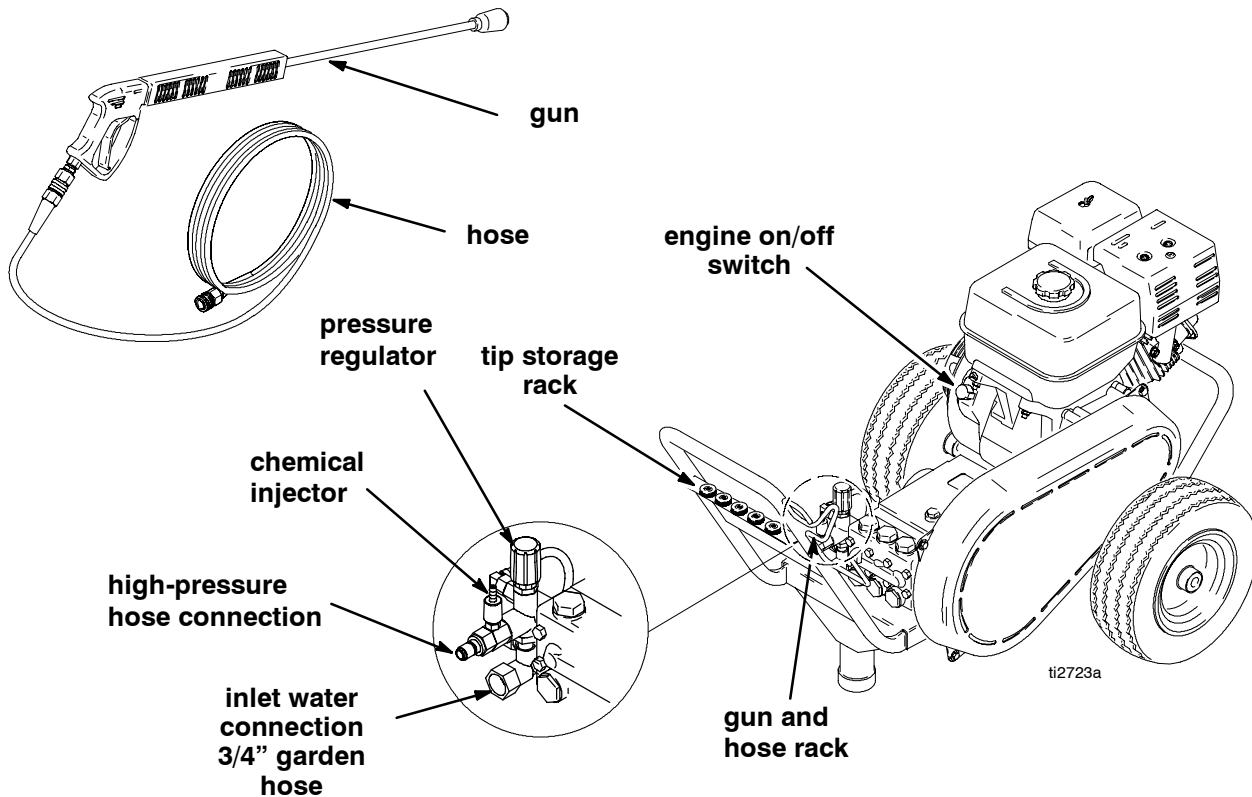

Check for Shipping Damage

Check the pressure washer for shipping damage. If anything is damaged, notify the carrier immediately.

Set Up

Connect the high-pressure hose between the pump outlet and the gun inlet. Both of these connections are made with quick couplers.

CAUTION

Up to 100 ft (30 m) of high-pressure hose may be used. Longer hoses may affect sprayer and chemical injector performance.

Install the appropriate spray tip on the wand. See **Installing and Changing Spray Tips** on page 6. If you use a sandblaster kit, see its separate manual for installation instructions.

Connect to Water Supply

CAUTION

Before you connect to the water supply, check your local plumbing code regarding cross connection to the water supply. Install a backflow preventer upstream from pump to prevent backflow of contaminated water into the fresh water supply.

If inlet water pressure is over 60 psi (414 kPa, 4.1 bar) Regulating Water Valve 800258 must be installed at the garden hose connection.

Do not exceed 160° F (70° C) inlet water temperature.

Connect a hose with at least a 3/4-in. (19 mm) ID from the water supply to the 3/4-in. garden hose inlet. The supply hose should not be more than 50 ft (15 m) long

NOTE: The water source *must* have a minimum flow rate equal to that of the pressure washer. See **Technical Data** on page 17.

Pressure Relief Procedure

! WARNING

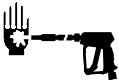
INJECTION HAZARD
 The system pressure must be manually relieved to prevent the system from spraying accidentally. To reduce the risk of an injury from accidental spray from the gun, splashing fluid, or moving parts, follow the **Pressure Relief Procedure** when you

- Are instructed to relieve the pressure
- Stop spraying for more than 10 minutes
- Check or service any of the system equipment
- Install or clean the spray nozzle

1. Engage the trigger safety latch.
2. Turn off the pressure washer, and remove the ignition cable from the spark plug.
3. Shut off the water supply.
4. Disengage the trigger safety latch, trigger the gun to relieve the pressure, and engage the trigger safety latch.

If you suspect that the spray tip or hose is clogged or that pressure has not been fully relieved after following the steps above: Disengage the trigger safety latch, and trigger the gun to relieve pressure. Wrap a rag around the hose end coupling, and **VERY SLOWLY** loosen the coupling to relieve pressure gradually. Then loosen it completely. Then clear the tip or hose.

Operation

Startup

Always use this startup procedure to ensure that the pressure washer is started safely and properly.

- Always engage the gun trigger safety latch when you stop spraying even for a moment. This reduces the risk of fluid injection or splashing in the eyes or on the skin if the gun is bumped or triggered accidentally.
 - Always observe the **CAUTIONS** in this section to avoid costly damage to the pressure washer.
 - If you use the Sandblaster Kit, see the Sandblaster Kit manual for detailed cleaning information.
1. Check the oil level.

NOTE: This pressure washer is equipped with a low-oil sensor that shuts the engine off if the oil level falls below a certain level. If the engine stops unexpectedly, check the oil and the fuel levels. Check the oil level each time you refuel.

2. Check the fuel level.

! WARNING

FIRE HAZARD
 Do not refuel a hot engine. Refueling a hot engine could cause a fire. Use only fresh, clean, regular or unleaded gasoline. Close the fuel shutoff valve during refueling.

3. Turn on the water supply.

! CAUTION

Never run the pressure washer dry. Costly damage to the pump will result. Always be sure the water supply is completely turned on before you run the pressure washer.

4. Trigger the gun until water sprays from the tip indicating that the air is purged from the system.
5. Open the fuel shutoff valve. Be sure the spark plug ignition cable is pushed firmly onto the spark plug. Put the engine switch in the ON position, and put the throttle in the RUN position.

! CAUTION

Do not allow the pressure washer to idle for more than 10 minutes. Doing so may cause the recirculating water to overheat and seriously damage the pump. Turn off the pressure washer if it will not be spraying or cleaning at least every 10 minutes. If heated inlet water is used, reduce this time further. Do not operate the pressure washer with the inlet water screen removed. This screen helps keep abrasive sediment, which could clog the pump or damage the pump cylinders, out of the pump. Keep this screen clean. Do not pump caustic materials; such materials could corrode the pump components.

Operation

- Pull the starter rope to start the engine. Brace one foot on the pressure washer cart, and pull the starter rope out quickly.

⚠ CAUTION

Do not allow the starter rope to snap back against the engine. Let the rope recoil gently to prevent damage to the recoil mechanism.

NOTE: For easier starting, have one person start the pressure washer while another person triggers the gun.

If the engine is cold, start the engine with the choke completely closed. In cool weather, you might have to let the engine run with the choke closed for the first 10 to 30 seconds. In warm weather, open the choke completely as soon as the engine starts.

If the engine is warm, start the engine with the choke completely open or partially closed. When the engine starts, open the choke completely.

Trigger Safety Latch

⚠ WARNING

To reduce the risk of serious bodily injury, including fluid injection or splashing in the eyes or on the skin, always engage the trigger safety latch when you stop spraying even for a moment. In the engaged position, the trigger safety latch prevents the gun from being triggered accidentally by hand or if it is dropped or bumped. Be sure the latch is pushed fully down, or it will not prevent the gun from being triggered. See Fig. 1.

Trigger Safety Latch

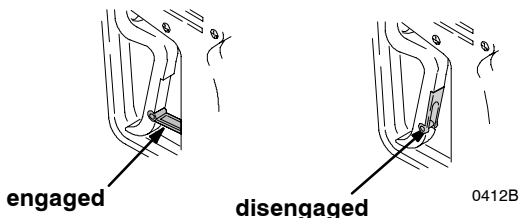

Fig. 1

Installing and Changing Spray Tips

Spray tips have 4- or 5-digit numbers on them. The first two digits are the spray angle. Select the spray tip appropriate for your application. Tip holding holes are provided on the chassis.

Spray Tip Number	Spray Pattern Fan Angle
00XXX	0° blaster (red)
15XXX	15° (yellow)
25XXX	25° (green)
40XXX	40° (white)

NOTE: The chemical injector tip is brass and has a large opening and a black plastic cap.



1. **Relieve the pressure.** See page 5.
2. Point the gun and wand away from yourself and anyone else.
3. Without holding your hand over the spray tip (A), pull back the quick coupler ring (B). Remove the current tip and/or install a different one. Then push back the ring. See Fig. 2.
4. Pull on the tip to be sure it is secure before you spray again.

⚠ CAUTION

To avoid blowing the O-ring out of the quick coupler due to the high pressure in the system, never operate the pressure washer without a tip securely mounted in the quick coupler.

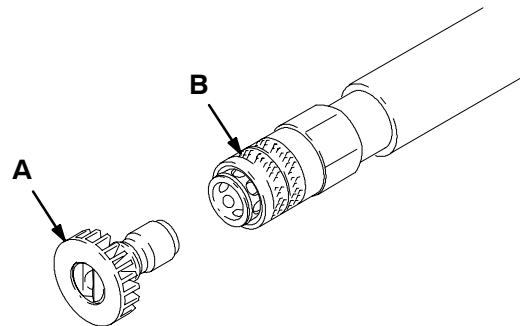

Fig. 2

04929

Operation

Chemical Injector Operation

1.   **Relieve the pressure.**
See page 5.

2. Insert the chemical filter (attached with clear tubing to the chemical injector) into the container of chemical.
3. Install the black, large orifice, chemical tip. See **Installing and Changing Spray Tips** on page 6.

The large orifice of the chemical top causes a drop in pressure that activates the chemical injector. Changing back to a small orifice spray tip de-activates the chemical injector and produces high pressure for rinsing. The chemical filter can be left in the chemical container during high pressure use. To regulate the flow rate of the chemical, turn the chemical adjustment knob on the injector. Maximum chemical flow is a full two turns counterclockwise from the CLOSED (clockwise) position.

Water Sandblasting

Water Sandblasting Kit 244766 is available for abrasive cleaning of stubborn dirt and paint. The kit requires a sandblasting tip, sold separately as follows:

- 3040 pressure washer uses sandblasting tip 805317.
- 3540 pressure washer uses sandblasting tip 805313.

Shutdown, Flushing, and Storage

CAUTION

Do not expose pressure washer to freezing temperatures or allow water to freeze in pressure washer components. If water freezes in the pressure washer, thaw it in a warm room before you try to start it. Do not pour hot water on or into the pump; it may crack the ceramic plungers!

- Do not store unit outside where it will be exposed to rain, dirt or adverse weather conditions.

Engine:

1. Run engine until gas is gone or stabilize the fuel and run it through the fuel system and carburetor.
2. Drain water out of pressure washer hose.

3. Turn fuel system to OFF position.

Pump:

4. Attach one end of a 4 or 5-foot section of hose to pump inlet and other end in an antifreeze solution approximately 1-foot off the ground.
5. Pull pull-cord on engine until antifreeze comes out of pump outlet.

Storage Location:

6. Store pressure washer in garage, basement or other area where it is protected from freezing temperatures.
- After each use, wipe all surfaces of the pressure washer with a clean, damp cloth.
 - Perform the appropriate maintenance. See **Maintenance Chart**, page 9.

Maintenance

Observing regular maintenance intervals helps ensure that you get maximum performance and life from the pressure washer.

There is a break-in period for the engine and pump. After you change the oil in these components following their respective break-in periods, the interval between required changes is longer.

If the pressure washer is operated in dusty conditions, these maintenance checks should be made more often.

Maintenance Chart



Relieve the pressure

(see page 5) before you proceed with maintenance.

Interval	What to do
Daily	Clean water inlet screen and filter. Check engine and pump oil levels. Fill as necessary. Check gasoline level. Fill as necessary.
After first 5 hours of operation	Change engine break-in oil. Drain oil when warm. Use SAE 30 or 10W-30 detergent oil.
After every 25 hours of operation	Clean and remove air cleaner foam. Wash with water and detergent. Dry thoroughly. Rub with oil, and squeeze to distribute oil.
After first 50 hours of operation	Change pump break-in oil. Use SAE 30 non-detergent oil.
After every 100 hours of operation, or every 3 months	Clean or replace paper air cleaner cartridge. Tap gently to remove dirt. Change engine oil. Use SAE 30 or 10W-30 detergent oil.
After every 500 hours of operation, or every 6 months	Change pump oil. Use SAE 30 non-detergent oil.

Pump Service

Repair kits are available. See **Pump Repair Kits** on page 15. For the best results, use all parts in the kits.



Relieve the pressure
(see page 5) before you proceed with service.

NOTES:

- The following metric wrenches are needed: 10 mm, 13 mm, and 30 mm.

Valves

NOTE: For a set of six valves, order 801472.

1. Remove the hex plug from the manifold using a 30 mm wrench.
2. Examine the o-ring under the hex plug and replace it if it is cut or distorted.
3. Remove the valve assembly from the cavity; the assembly may come apart.
4. Install the new valve. Install the o-ring and hex plug; torque to 75 ft-lb (103 N•m).

NOTE: Retorque the plug after 5 hours of operation.

Pump Section

1. Remove the eight capscrews and lockwashers from the manifold using a 13 mm wrench.
2. Carefully separate the manifold from the crankcase.

NOTE: You might have to tap the manifold lightly with a soft mallet to loosen it.

⚠ CAUTION

To avoid damage to the plunger or seals, keep the manifold properly aligned with the ceramic plungers when you remove it.

3. Carefully examine each plunger for any scoring or cracking, and replace as necessary.

Servicing the Plungers

NOTE: Plunger repair kit 801474 is available to replace retainers, o-rings, washers, and backup rings for three cylinders.

1. Loosen the plunger retaining screw five to six turns. Push the plunger towards the crankcase to separate the plunger and retaining screw.
2. Remove the screw from the plunger, and examine the o-ring, backup ring, and copper bearing/gasket washer. Replace these parts, if necessary.
3. Remove the plunger and flinger from the plunger shaft. Clean, examine, and replace parts as necessary.
4. Inspect the plunger shaft for oil leakage from the crankcase. If leaking is obvious, replace the oil seals. Otherwise, DO NOT remove these seals because they cannot be reused. Oil Seal Kit 801473 is available for replacing the seals.
5. Lightly grease the flinger (and the oil seal if it is being replaced), and replace on the plunger shaft. Then install the plunger.

Pump Service

6. Lightly grease the retaining screw and the outer end of the plunger. Place the washer, o-ring, and backup ring around the screw, and install the screw through the plunger. Torque to 14.4 ft-lb (19.5 N•m).

NOTE: If you plan to replace the packings, See **Servicing the V-Packings** at right.

7. Lubricate the outside of each plunger. Slide the manifold onto the crankcase, being careful not to damage the seals.
8. Install the capscrews and washers finger tight. Torque the screws to 22.1 ft-lb (30 N•m) following the tightening pattern in Fig. 3. Uneven tightening can cause the manifold to bind or jam.

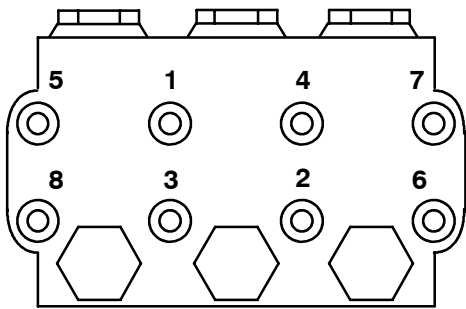

Fig. 3

Servicing the V-Packings

NOTE: There are two types of packing kits:

801486 contains packings only.

801487 contains packings, rings, and retainers.

1. Remove the manifold as outlined in **Pump Section** on page 10.
2. Carefully pull the packing retainer from the manifold. Examine the o-ring, and replace if cut or damaged.
3. Remove the V-packing and head ring. Pull out the intermediate retainer ring. Remove the second V-packing and second head ring.
4. Inspect all parts, and replace as necessary.
5. Thoroughly clean the packing cavities, and examine for debris or damage.
6. Lightly grease the packing cavities, and replace the packings in the following order: head ring, V-packing, intermediate ring, head ring, V-packing, packing retainer. Install the O-ring in the retainer groove.

CAUTION

Install the parts in the proper order and facing the proper direction. Improperly installed parts will cause a malfunction.



7. Reassemble the manifold as instructed in **Servicing the Plungers** on page 10.

Pressure Washer Parts

Model 246454, Series A: 3040 Pressure Washer

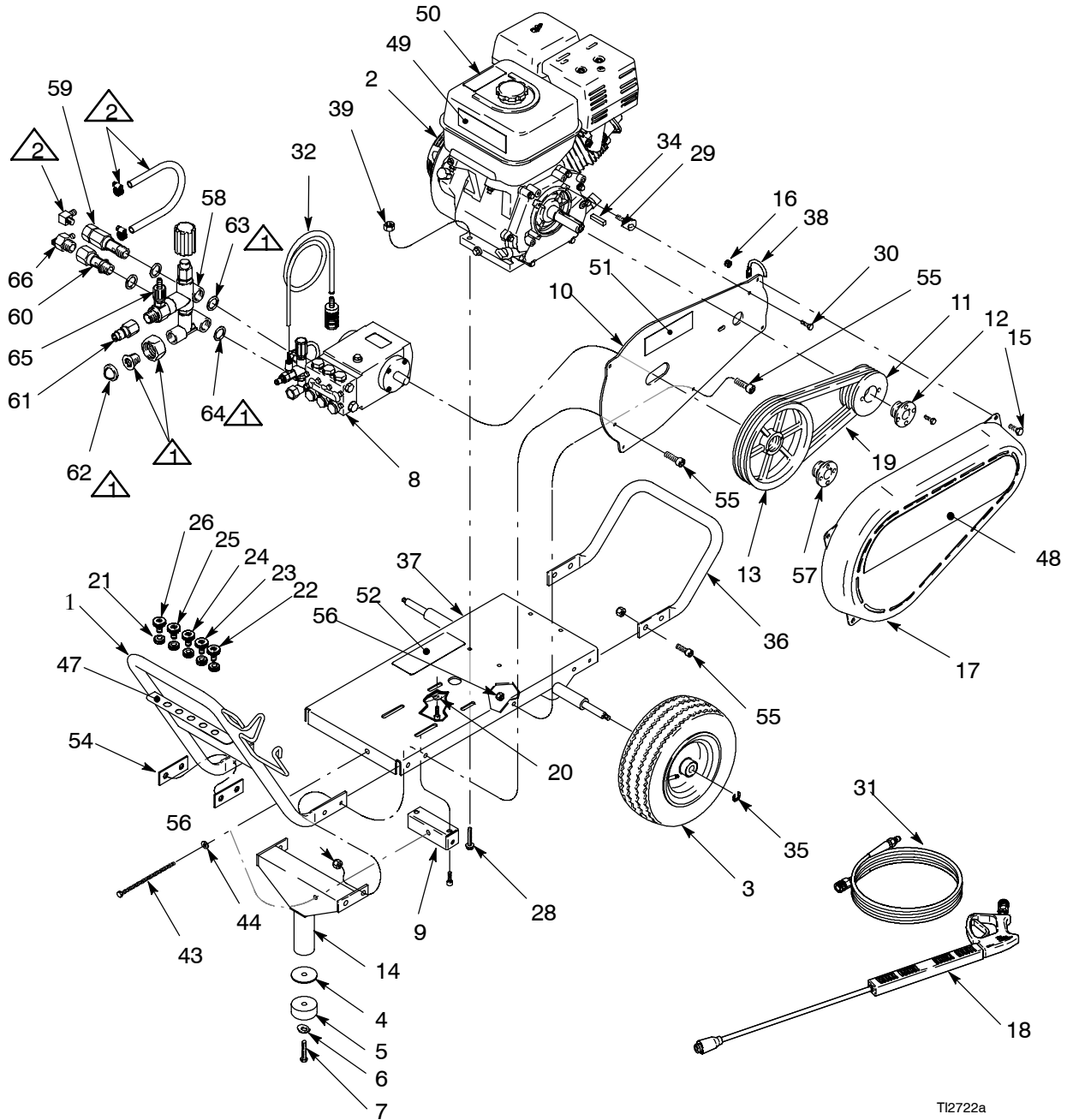
Model 246455, Series A: 3540 Pressure Washer



-  Included with 58
-  Included with 66

T12722a

Pressure Washer Parts

Ref. No.	Part No.	Description	Qty.	Ref. No.	Part No.	Description	Qty.
1	287111	HANDLE, cart	1	34	801137	KEY, square	1
2	803158	ENGINE, gx340,11 hp	1	35	101242	RING, retaining, ext.	2
	114703	ENGINE, gx390,13 hp used on Model 246455	1	36	15C032	BUMPER, frame	1
3	116399	WHEEL, pneumatic	2	37	287110	FRAME, cart	1
4	15B829	WASHER, flat, black	1	38	15C089	HOOK, gun	1
5	801504	FOOT, rubber	1	39	117697	NUT, lock, heavy hex	4
6	100132	WASHER, flat	1	43	117716	SCREW, cap, hex head	1
7	100003	SCREW, cap, hex hd	1	44	100527	WASHER, wrought	1
8	246553	PUMP, assembly	1	47	15C131▲	LABEL, pressure washer, 3040 used on Model 246454	1
9	801526	BRACKET, mounting	1		15C095 ▲	LABEL, pressure washer, 3540 used on Model 246455	1
10	15C097	GUARD, back, blue	1	48	15C132▲	LABEL, presher washer, 3040 used on Model 246454	1
11	15B656	PULLEY	1		15C096▲	LABEL, pressure washer, 3540 used on Model 246455	1
12	801898	BUSHING	1	49	802363 ▲	LABEL, caution	1
13	803944	SHEAVE	1	50	290013 ▲	LABEL, warning	1
14	287109	LEG, front	1	51	804495▲	LABEL, warning	1
15	110963	SCREW, cap, flng hd	4	52	804500 ▲	LABEL, warning	1
16	111040	NUT,lock, insert, nylock, 5/16	4	54	15C091	ISOLATOR, handle	2
17	803926	GUARD, belt, (blue)	1	55	501206	SCREW, socket hd	9
18	244784	GUN, coupling assembly	1	56	101566	NUT, lock	9
19	117692	BELT	2	57	801135	BUSHING	1
20	108851	WASHER, plain	2	58	246554	KIT, unloader used on Model 246454	1
21	801012	GROMMET	5		246546	KIT, unloader used on Model 246455	1
22	805547	TIP, spray, q-type	1	59	246550	KIT, ez start	1
23	805548	TIP, spray, q-type	1	60	246549	KIT, fitting	1
24	805549	TIP, spray, q-type	1	61	801568	QUICK COUPLER, 3/8 female	1
25	805550	TIP, spray, q-type	1	62	804051	SCREEN	1
26	805634	TIP, spray, q-type	1	63	804570	WASHER	2
28	117779	SCREW, hex head, flanged	4	64	804569	WASHER	2
29	804356	INSULATOR, vibration	1	65	246551	KIT, injector	1
30	804376	SCREW, cap, hex hd	1	66	246552	KIT, pump thermal protector	1
31	244783	HOSE, 4000, assembly	1				
32	804275	TUBING, chemical, 1/4 id x 8ft	1				

▲ Replacement Danger and Warning labels, tags and cards are available at not cost.

Pump Kit Parts

Pump Model 246553 - kit parts breakdown

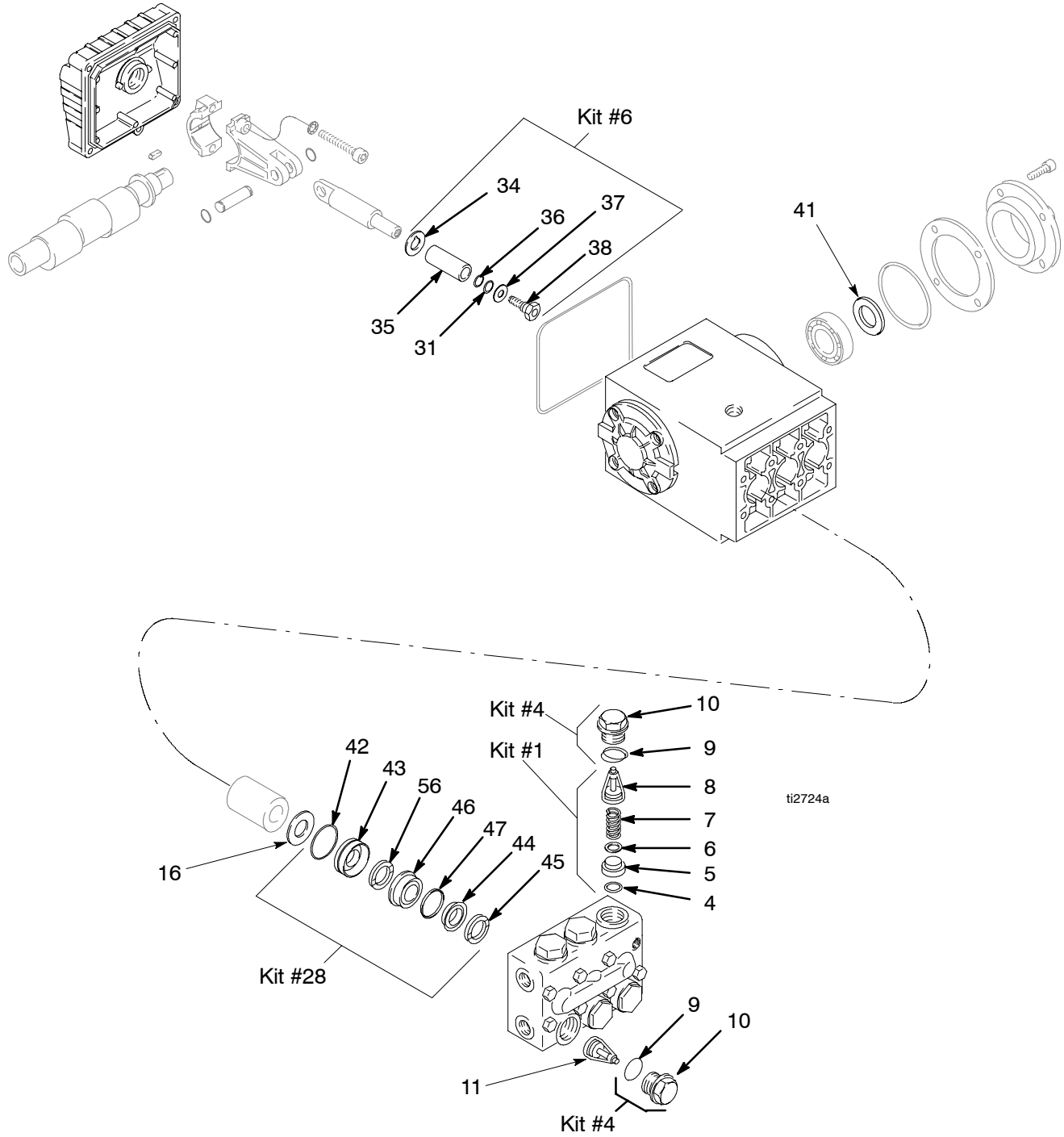

Pump Kit Parts

Ref. No.	Part No.	Description	Qty	Ref. No.	Part No.	Description	Qty
4	KIT 1	O-RING		35	801490	PLUNGER, ceramic	3
5	KIT 1	SEAT, valve		36	KIT 6	RING, backup	
6	KIT 1	PLATE, valve		37	KIT 6	WASHER	
7	KIT 1	SPRING		38	KIT 6	SCREW, piston	
8	KIT 1	GUIDE, valve		41	KIT 3	SEAL, oil	
9	KIT 4	O-RING		42	KIT 28	O-RING	
10	KIT 4	CAP		43	KIT 28	RETAINER, packing	
11	KIT 1	VALVE ASSEMBLY <i>(includes 4 to 8)</i>		44	KIT 8, 28	PACKING	
16	KIT 2	SEAL, oil		45	KIT 28	RING, head	
31	KIT 6	O-RING		46	KIT 28	RETAINER, packing	
34	801660 and KIT 6	WASHER, flinger	3	47	KIT 28	RING, long life	

Pump Repair Kits

Kit No.	Repair Kit Part No.	Ref. No.	Description	Qty
1	801472 Valve	11	VALVE ASSEMBLY <i>(includes 4 to 8)</i>	6
		4	O-RING	6
		5	SEAT, valve	6
		6	PLATE, valve	6
		7	SPRING	6
		8	GUIDE, valve	6
2	801473 Oil Seal	16	SEAL, oil	3
3	802511 Crankshaft Seal	41	SEAL, oil	2
4	802306 Valve Cap	9	O-RING	6
		10	CAP	6

Kit No.	Repair Kit Part No.	Ref. No.	Description	Qty
6	801474 Plunger Repair	31	O-RING	3
		34	WASHER, flinger	3
		36	RING, backup	3
		37	WASHER	3
		38	SCREW, piston	3
8	801486 Packing	44	PACKING	6
28	801487 Packing and Retainer	42	O-RING	1
		43	RETAINER, packing	1
		44	PACKING	1
		45	RING, head	1
		46	RETAINER, packing	1
		47	RING, long life	1
	56	SEAL, low pressure	1	

Troubleshooting



Relieve the pressure (see page 5) before you proceed with troubleshooting.

PROBLEM	CAUSE	SOLUTION
Engine not starting or hard to start	No gasoline in fuel tank or carburetor Low oil Start/Stop switch in STOP position Water in fuel, or old fuel Engine flooded or improperly choked Dirty air cleaner filter Spark plug dirty, wrong gap, or wrong type Gun not triggered	Fill the tank with gasoline, and open fuel shut off valve. Check fuel line and carburetor. Add oil to proper level. Move switch to START position. Drain fuel tank and carburetor. Use new fuel, and make sure dry spark plug is dry. Open choke, and crank engine several times to clear out gas. Make sure spark plug is dry. Remove and clean. Clean, adjust the gap, or replace. Trigger gun while starting engine.
Engine missing or lacking power	Partially plugged air cleaner filter Spark plug dirty, wrong gap, or wrong type	Remove and clean. Clean, adjust the gap, or replace.
Pressure too low and/or pump running roughly	Worn or wrong size tip Inlet filter clogged Worn packings, abrasives in water, or natural wear Inadequate water supply Belts slipping Fouled or dirty inlet or discharge valves Restricted inlet Worn inlet or discharge valves Leaking high-pressure hose	Replace with tip of proper size. Clean. Check more frequently. Check filter. Replace packings. See Pump Service on page 10. Check water flow rate to pump. Tighten or replace; use correct belts, and replace both at same time. Clean inlet and discharge valve assemblies. Check filter. Check if garden hose is collapsed or kinked. Replace worn valves. See Pump Service on page 10. Replace high-pressure hose.
Water leaking from under pump manifold	Worn packings	Install new packings. See Pump Service on page 10.
Water in pump oil	Humid air condensing inside crankcase Worn packings Oil seals leaking	Change oil as specified in Maintenance on page 9. Install new packings. See Pump Service on page 10. Install new oil seals. See Pump Service on page 10.
Packings failing frequently or prematurely.	Scored, damaged, or worn plungers Abrasive material in the fluid being pumped Inlet water temperature too high Overpressurizing pump Excessive pressure due to partially plugged or damaged tip Pump running too long without spraying Running pump dry	Install new plungers. See Pump Service on page 10. Install proper filtration on pump inlet plumbing. Check water temperature. It should not exceed 160°F (70°C). Do not modify any factory-set adjustments. See EQUIPMENT MISUSE HAZARD on page 3. Clean or replace tip. See Installing and Changing Spray Tips on page 6. Never run pump more than 10 minutes without spraying. Do not run pump without water.
Strong surging at inlet, and low pressure on discharge side	Foreign particles in the inlet or discharge valve, or worn inlet and/or discharge valves	Clean or replace valves. See Pump Service on page 10.

Technical Data

	3040 Model 246454	3540 Model 246455
Engine (4 cycle, air cooled)	11 HP Honda OHV	13 HP Honda OHV
Gasoline tank capacity	6.9 quarts (6.5 liters)	6.9 quarts (6.5 liters)
Water pump maximum operating pressure	3000 psi (21 MPa, 207 bar)	3500 psi (24.1 MPa, 241 bar)
Water pump maximum flow	4 gpm (15 lpm)	4 gpm (15 lpm)
Inlet hose connection	3/4" garden hose (f)	3/4" garden hose (f)
Weight	180 lb (82 kg)	180 lb (82 kg)
Dimensions		
Length	45" (1143mm)	45" (1143mm)
Width	27" (686mm)	27" (686mm)
Height	25" (635mm)	25" (635mm)
Sound levels		
Sound pressure	94 dB (A)	94 dB (A)
Sound power	108 dB (A)	108 dB (A)
Maximum inlet water temperature	160° F (70° C)	160° F (70° C)
Wetted parts	Acrylonitrile and Buna-N cover and tube Synthetic yarn and EPDM Anodized aluminum; aluminum or bronze alloys; brass copper; nylon-PTFE composite; ceramic; Buna-N; cotton phenolic; 303, 304, and 316 stainless steel; polyimide-12 thermoplastic; PTFE; carbon steel; zinc plate with or without yellow chromate	

Graco Standard Warranty

Graco warrants all equipment listed in this manual which is manufactured by Graco and bearing its name to be free from defects in material and workmanship on the date to the original purchaser for use. With the exception of any special extended or limited warranty published by Graco, Graco will, for a period of twelve months from the date of sale, repair or replace any part of the equipment determined by Graco to be defective. This warranty applies only when the equipment is installed, operated and maintained in accordance with Graco's written recommendations.

This warranty does not cover, and Graco shall not be liable for general wear and tear, or any malfunction, damage or wear caused by faulty installation, misapplication, abrasion, corrosion, inadequate or improper maintenance, negligence, accident, tampering, or substitution of non-Graco component parts. Nor shall Graco be liable for malfunction, damage or wear caused by the incompatibility of Graco equipment with structures, accessories, equipment or materials not supplied by Graco, or the improper design, manufacture, installation, operation or maintenance of structures, accessories, equipment or materials not supplied by Graco.

This warranty is conditioned upon the prepaid return of the equipment claimed to be defective to an authorized Graco distributor for verification of the claimed defect. If the claimed defect is verified, Graco will repair or replace free of charge any defective parts. The equipment will be returned to the original purchaser transportation prepaid. If inspection of the equipment does not disclose any defect in material or workmanship, repairs will be made at a reasonable charge, which charges may include the costs of parts, labor, and transportation.

Graco's sole obligation and buyer's sole remedy for any breach of warranty shall be as set forth above. The buyer agrees that no other remedy (including, but not limited to, incidental or consequential damages for lost profits, lost sales, injury to person or property, or any other incidental or consequential loss) shall be available. Any action for breach of warranty must be brought within two (2) years of the date of sale.

GRACO MAKES NO WARRANTY, AND DISCLAIMS ALL IMPLIED WARRANTIES OF MERCHANTABILITY AND FITNESS FOR A PARTICULAR PURPOSE IN CONNECTION WITH ACCESSORIES, EQUIPMENT, MATERIALS OR COMPONENTS SOLD BUT NOT MANUFACTURED BY GRACO. These items sold, but not manufactured by Graco (such as electric motors, gas engines, switches, hose, etc.), are subject to the warranty, if any, of their manufacturer. Graco will provide purchaser with reasonable assistance in making any claim for breach of these warranties.

In no event will Graco be liable for indirect, incidental, special or consequential damages resulting from Graco supplying equipment hereunder, or the furnishing, performance, or use of any products or other goods sold hereto, whether due to a breach of contract, breach of warranty, the negligence of Graco, or otherwise.

FOR GRACO CANADA CUSTOMERS

The parties acknowledge that they have required that the present document, as well as all documents, notices and legal proceedings entered into, given or instituted pursuant hereto or relating directly or indirectly hereto, be drawn up in English. Les parties reconnaissent avoir convenu que la rédaction du présente document sera en Anglais, ainsi que tous documents, avis et procédures judiciaires exécutés, donnés ou intentés à la suite de ou en rapport, directement ou indirectement, avec les procédures concernées.

ADDITIONAL WARRANTY COVERAGE

Graco does provide extended warranty and wear warranty for products described in the "Graco Contractor Equipment Warranty Program".

Graco Phone Number

TO PLACE AN ORDER, contact your Graco distributor, or call this number to identify the distributor closest to you:
1-800-690-2894 Toll Free

*All written and visual data contained in this document reflect the latest product information available at the time of publication.
Graco reserves the right to make changes at any time without notice.*

Graco Headquarters: Minneapolis
International Offices: Belgium, Korea, China, Japan

GRACO INC. P.O. BOX 1441 MINNEAPOLIS, MN 55440-1441

www.graco.com

PRINTED IN USA 309732 1/2003/Revised 10/2008