

# OPERATION – UTILIZAÇÃO – FONCTIONNEMENT – FUNCIONAMIENTO



**309402** Rev. C

## Line Driver™

### Model 233725

10 mph (16 kph) Maximum Operating Speed / de vitesse de fonctionnement maximum / de velocidade operando se máxima / de la velocidad de funcionamiento máxima

Related manuals  
Manuais associados  
Manuels afférents  
Manuales relacionados

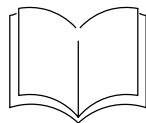

..... [309404](#)



..... [309405](#)

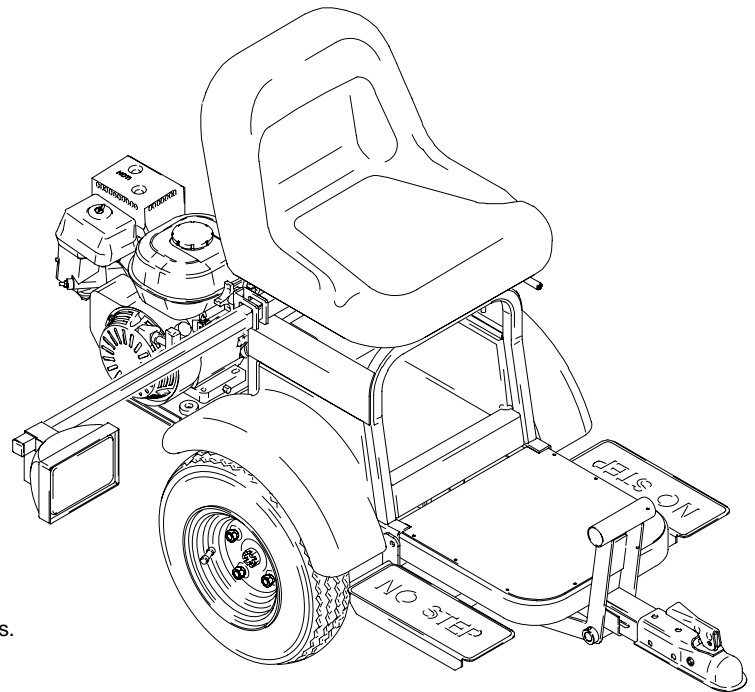

All models not available in all countries.  
Nem todos os modelos existem à disposição em todos os países.  
Tous les modèles ne sont pas disponibles dans tous les pays.  
Hay modelos que no se distribuyen en todos los países.

#### How To Perform:

- **Component Identification** ..... 4
- **Setup** ..... 6
- **Startup** ..... 9
- **Operation** ..... 9

GRACO INC. P.O. BOX 1441 MINNEAPOLIS, MN 55440-1441

©COPYRIGHT 2001, GRACO INC.

Graco Inc. is registered to I.S. EN ISO 9001



HO03



# WARNING

## MOVING VEHICLE HAZARD

Careless and reckless behavior causes accidents. Falling from vehicle, running into people or objects, or being struck by other vehicles may result in serious injury or death.

- Use appropriate traffic control in all traffic areas
- Do not step on forward/reverse pedals
- Make turns slowly
- Do not carry passengers
- Do not operate on slopes greater than 15°
- Loss of traction may occur going downhill
- Reference Manual on Uniform Traffic Control Devices (MUTCD), U.S. Department of Transportation, Federal Highway Administration or local highway and transportation regulations for proper traffic control.
- Do not make turns greater than 45°
- Do not tow
- Use with line striping equipment only



## MOVING VEHICLE HAZARD

Careless and reckless behavior causes accidents. Falling from vehicle, running into people or objects, or being struck by other vehicles may result in serious injury or death.

- Use appropriate traffic control in all traffic areas
- Do not step on forward/reverse pedals
- Make turns slowly
- Do not carry passengers
- Do not operate on slopes greater than 15°
- Loss of traction may occur going downhill
- Reference Manual on Uniform Traffic Control Devices (MUTCD), U.S. Department of Transportation, Federal Highway Administration or local highway and transportation regulations for proper traffic control.
- Do not make turns greater than 45°
- Do not tow
- Use with line striping equipment only

## FIRE AND EXPLOSION HAZARD

Fuel spilled on a hot surface can cause a fire or explosion and serious bodily injury or death. Shut off engine and let engine cool before filling tank.



## FIRE AND EXPLOSION HAZARD

Fuel spilled on a hot surface can cause a fire or explosion and serious bodily injury or death. Shut off engine and let engine cool before filling tank.

## HOT SURFACE HAZARD

Engine and drive housing may be very hot during operation and could burn skin if touched.



## HOT SURFACE HAZARD

Engine and drive housing may be very hot during operation and could burn skin if touched.

## TOXIC FUMES HAZARD

Engine produces carbon monoxide which is a deadly gas. Do not operate in an enclosed area. Breathing carbon monoxide may result in serious injury or death.



## TOXIC FUMES HAZARD

Engine produces carbon monoxide which is a deadly gas. Do not operate in an enclosed area. Breathing carbon monoxide may result in serious injury or death.



# WARNING

## MOVING VEHICLE HAZARD

Careless and reckless behavior causes accidents. Falling from vehicle, running into people or objects, or being struck by other vehicles may result in serious injury or death.

- Use appropriate traffic control in all traffic areas
- Do not step on forward/reverse pedals
- Make turns slowly
- Do not carry passengers
- Do not operate on slopes greater than 15°
- Loss of traction may occur going downhill
- Reference Manual on Uniform Traffic Control Devices (MUTCD), U.S. Department of Transportation, Federal Highway Administration or local highway and transportation regulations for proper traffic control.
- Do not make turns greater than 45°
- Do not tow
- Use with line striping equipment only



## MOVING VEHICLE HAZARD

Careless and reckless behavior causes accidents. Falling from vehicle, running into people or objects, or being struck by other vehicles may result in serious injury or death.

- Use appropriate traffic control in all traffic areas
- Do not step on forward/reverse pedals
- Make turns slowly
- Do not carry passengers
- Do not operate on slopes greater than 15°
- Loss of traction may occur going downhill
- Reference Manual on Uniform Traffic Control Devices (MUTCD), U.S. Department of Transportation, Federal Highway Administration or local highway and transportation regulations for proper traffic control.
- Do not make turns greater than 45°
- Do not tow
- Use with line striping equipment only

## FIRE AND EXPLOSION HAZARD

Fuel spilled on a hot surface can cause a fire or explosion and serious bodily injury or death. Shut off engine and let engine cool before filling tank.



## FIRE AND EXPLOSION HAZARD

Fuel spilled on a hot surface can cause a fire or explosion and serious bodily injury or death. Shut off engine and let engine cool before filling tank.

## HOT SURFACE HAZARD

Engine and drive housing may be very hot during operation and could burn skin if touched.



## HOT SURFACE HAZARD

Engine and drive housing may be very hot during operation and could burn skin if touched.

## TOXIC FUMES HAZARD

Engine produces carbon monoxide which is a deadly gas. Do not operate in an enclosed area. Breathing carbon monoxide may result in serious injury or death.



## TOXIC FUMES HAZARD

Engine produces carbon monoxide which is a deadly gas. Do not operate in an enclosed area. Breathing carbon monoxide may result in serious injury or death.

# Component Identification

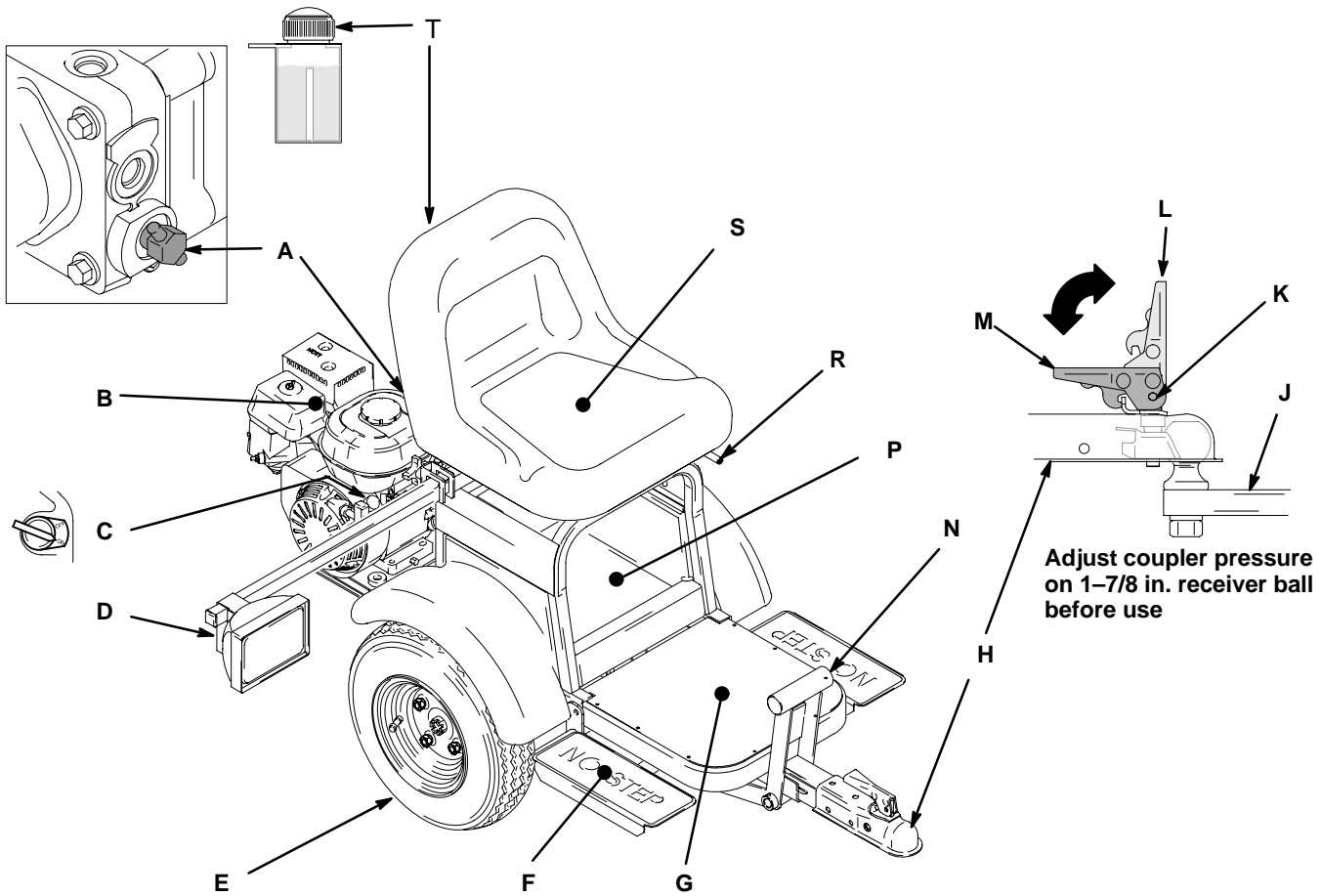

A	Wheel Release			
B	Engine			
C	Engine ON/OFF			
D	Light			
E	Tires: inflate to equal and Rated Pressure			
F	Direction/Speed Pedals			
G	Step Plate			
H	Coupler			
J	Hitch			
K	Safety Pin Location			
L	Handle Open			
M	Handle Locked			
N	Parking Brake			
P	Storage			
R	Seat Adjustment			
S	Operator Seat			
T	Hydraulic Fill Cap			

# Setup

---

## Unpack Line Driver

---

1. Remove Line Driver from packing.
2. Disengage drive wheels. This makes it easier to roll the Line Driver.
3. Hand tighten after use.

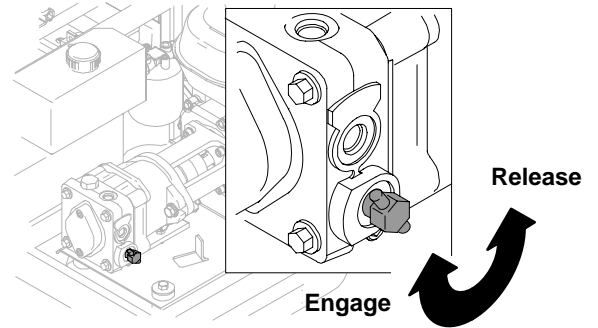

---

## Connect Hitch Receiver to Line Striper – Hitch Receiver Kit 245321 Manual 309405

---

---

## Connect Line Driver to Line Striper

---

1. Install Line Driver hitch coupler to LineLazer hitch receiver ball.
2. Latch coupler to locked position (M)
3. Insert safety pin in latch

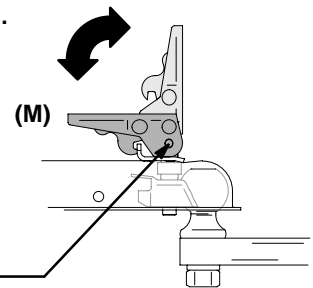

# Setup

---

## Individual Operator Adjustments

---

### Seat

Adjust seat forward/backward with lever (R) below seat

---

### Pedals

Suggestion: Adjust one pedal for full motion forward and one for full motion in reverse. This reduces fatigue.

1. Loosen two bolts (C) at underside of pedals

2. Rotate pedal to desired position

3. Tighten bolts.

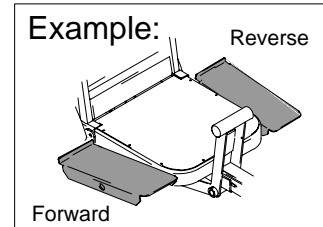
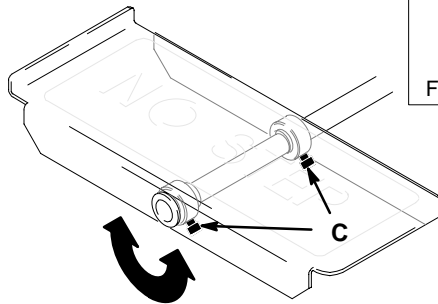

---

### Striper Handle Bars

Refer to your striper manual

# Startup

---

1. Check engine oil level. Add SAE 10W–30 (summer) or 5W–20 (winter), if necessary. Note: Keep engine oil at full level to avoid nuisance stalls because Oil Alert may sense low oil levels during change of direction of Line Driver

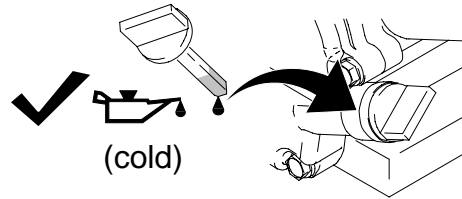

- 
2. Fill fuel tank.

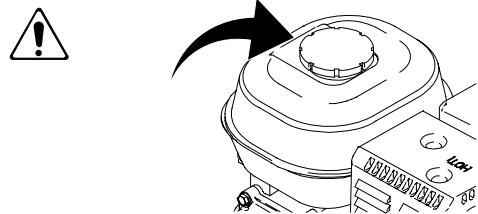

- 
3. **Check hydraulic oil level.** Add only **Mobil 1** (15W–50) synthetic oil. Hydraulic system capacity is 2 quarts.

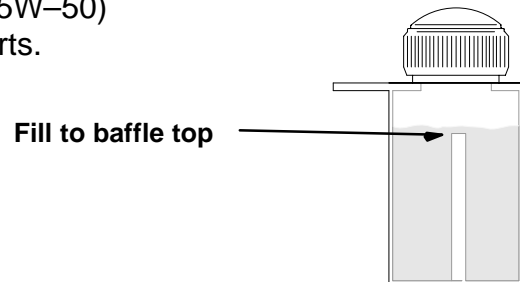

# Startup

---

## 4. Start engine

- a. Engage parking brake
- b. Move fuel valve to open
- c. Move choke to closed
- d. Set throttle to fast
- e. Set engine switch ON
- f. Pull starter cord
- g. After engine starts, move choke to open
- h. Set throttle to desired speed for striping.

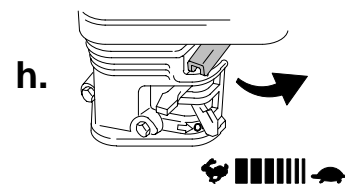
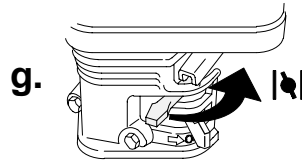
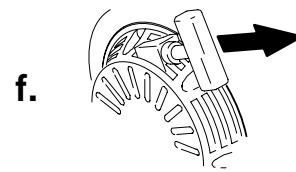
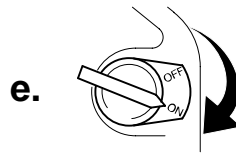
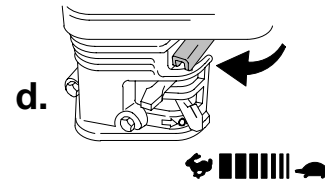
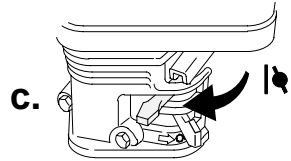
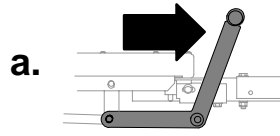

# Operation

---

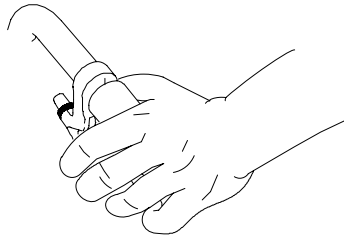

**Note:** Line Driver motion is forward and reverse. Turns are made with the striper.

1. Squeeze hand control and release caster wheel.

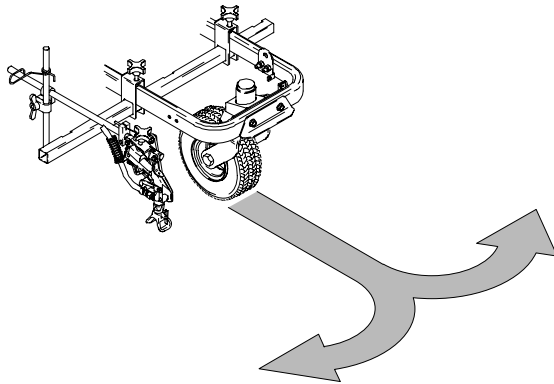

2. Push striper handle bars to begin desired turn.

# Operation

**Note: Line Driver stops when both feet are removed from pedals**

1. Move pedal(s) forward to drive Line Driver forward
2. Move pedal(s) reverse to drive Line Driver reverse
3. Switching from forward to reverse creates a braking action

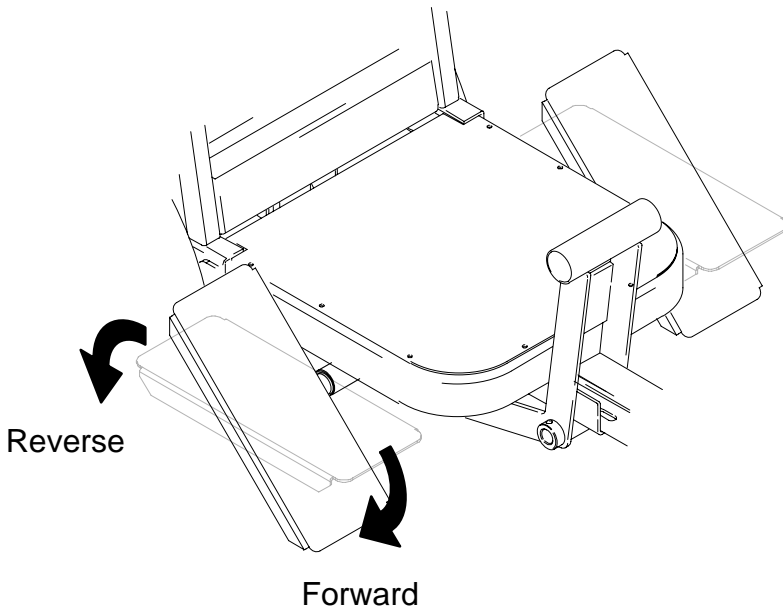

4. Set parking brake when not operating Line Driver

**Note: The Line Driver can not be started if the parking brake is not set. The operator must be seated when the parking brake is released or the Line Driver will stop running.**

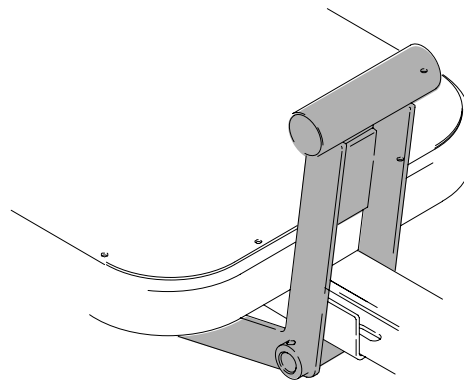
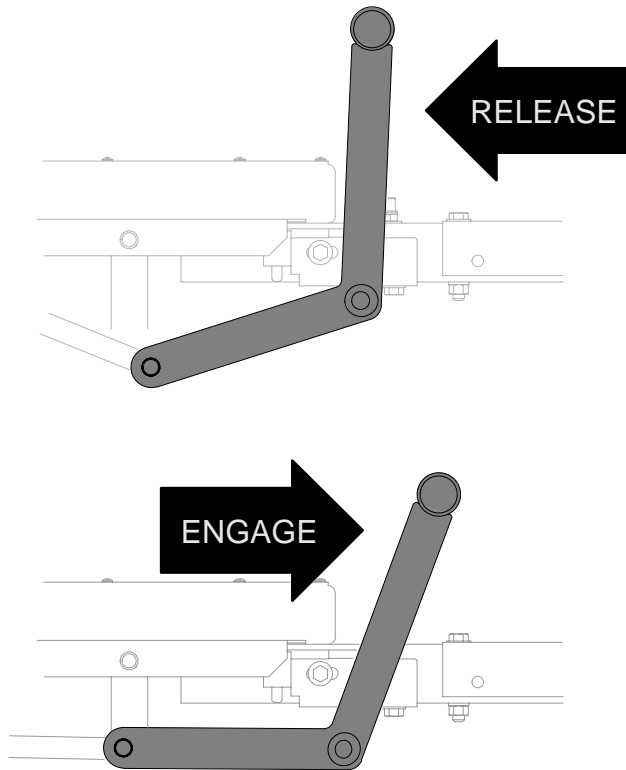

# Troubleshooting

PROBLEM	CAUSE	SOLUTION
Engine does not start	Parking brake not engaged. Engine switch OFF, no gasoline or low oil	Set Brake. Consult engine manual, supplied
Engine races to high rpm – stalls during operation	Worn governor	Consult engine manual, supplied
Engine operates, Line Driver does not move forward or reverse	Low hydraulic oil	Fill with <b>Mobil 1</b> (15W–50) synthetic oil
Engine operates, Line Driver moves slowly in forward and reverse	Low hydraulic oil. Parking brake is set Wheel release is open.	Fill with <b>Mobil 1</b> (15W–50) synthetic oil. Release parking brake. Close; hand tight.
Engine shuts off when operator exits Line Driver	Safety switch	Set parking brake
Engine continues to run when operator exits Line Driver and parking brake is not set	Safety switch	Adjust and set parking brake. Replace safety switch and/or any connecting wires.
Engine misses during turns and forward and reverse changes	Engine oil low	Consult engine manual for proper oil
Parking brake does not keep Line Driver from moving	Parking brake needs adjustment	Adjust brake. Manual 309404.
Line Driver creeps in forward or reverse direction	Control linkage needs adjustment	Adjust control linkage. Manual 309404.

# Graco Warranty

Graco warrants all equipment listed in this manual which is manufactured by Graco and bearing its name to be free from defects in material and workmanship on the date of sale to the original purchaser for use. With the exception of any special extended or limited warranty published by Graco, Graco will, for a period of twelve months from the date of sale, repair or replace any part of the equipment determined by Graco to be defective. This warranty applies only when the equipment is installed, operated and maintained in accordance with Graco's written recommendations.

This warranty does not cover, and Graco shall not be liable for general wear and tear, or any malfunction, damage or wear caused by faulty installation, misapplication, abrasion, corrosion, inadequate or improper maintenance, negligence, accident, tampering, or substitution of non-Graco component parts. Nor shall Graco be liable for malfunction, damage or wear caused by the incompatibility of Graco equipment with structures, accessories, equipment or materials not supplied by Graco, or the improper design, manufacture, installation, operation or maintenance of structures, accessories, equipment or materials not supplied by Graco.

This warranty is conditioned upon the prepaid return of the equipment claimed to be defective to an authorized Graco distributor for verification of the claimed defect. If the claimed defect is verified, Graco will repair or replace free of charge any defective parts. The equipment will be returned to the original purchaser transportation prepaid. If inspection of the equipment does not disclose any defect in material or workmanship, repairs will be made at a reasonable charge, which charges may include the costs of parts, labor, and transportation.

Graco's sole obligation and buyer's sole remedy for any breach of warranty shall be as set forth above. The buyer agrees that no other remedy (including, but not limited to, incidental or consequential damages for lost profits, lost sales, injury to person or property, or any other incidental or consequential loss) shall be available. Any action for breach of warranty must be brought within two (2) years of the date of sale.

**GRACO MAKES NO WARRANTY, AND DISCLAIMS ALL IMPLIED WARRANTIES OF MERCHANTABILITY AND FITNESS FOR A PARTICULAR PURPOSE IN CONNECTION WITH ACCESSORIES, EQUIPMENT, MATERIALS OR COMPONENTS SOLD BUT NOT MANUFACTURED BY GRACO.** These items sold, but not manufactured by Graco (such as electric motors, gas engines, switches, hose, etc.), are subject to the warranty, if any, of their manufacturer. Graco will provide purchaser with reasonable assistance in making any claim for breach of these warranties.

In no event will Graco be liable for indirect, incidental, special or consequential damages resulting from Graco supplying equipment hereunder, or the furnishing, performance, or use of any products or other goods sold hereto, whether due to a breach of contract, breach of warranty, the negligence of Graco, or otherwise.

## **FOR GRACO CANADA CUSTOMERS**

The parties acknowledge that they have required that the present document, as well as all documents, notices and legal proceedings entered into, given or instituted pursuant hereto or relating directly or indirectly hereto, be drawn up in English. Les parties reconnaissent avoir convenu que la rédaction du présente document sera en Anglais, ainsi que tous documents, avis et procédures judiciaires exécutés, donnés ou intentés à la suite de ou en rapport, directement ou indirectement, avec les procédures concernées.

## **ADDITIONAL WARRANTY COVERAGE**

Graco does provide extended warranty and wear warranty for products described in the "Graco Contractor Equipment Warranty Program".

# Graco Phone Number

**TO PLACE AN ORDER**, contact your Graco distributor, or call this number to identify the distributor closest to you:  
**1-800-690-2894 Toll Free.**

*All written and visual data contained in this document reflects the latest product information available at the time of publication.  
Graco reserves the right to make changes at any time without notice.*

mm 309402

This manual contains English, Portuguese, French, Spanish

**Graco Headquarters:** Minneapolis

**International Offices:** Belgium, Korea, China, Japan

**GRACO INC. P.O. BOX 1441 MINNEAPOLIS, MN 55440-1441**

**<http://www.graco.com>**

10/2001, Revised 8/2006