



This manual contains important warnings and information.  
**READ AND KEEP FOR REFERENCE.**

INSTRUCTIONS

**GRACO**  
First choice when quality counts.™

## Two- , Three- , and Four-Stage HVLP Turbine Sprayers

120V AC 50/60 Hz

**HVLP 2500™ with Two-Stage Turbine**

Model 233421

*5 psi (34 kPa, 0.3 bar) Maximum Working Pressure*

**HVLP 3800™ with Three-Stage Turbine**

Model 233422

*6 psi (41 kPa, 0.4 bar) Maximum Working Pressure*

**HVLP 4900™ with Four-Stage Turbine**

Model 233425

*8 psi (55 kPa, 0.5 bar) Maximum Working Pressure*

Model descriptions are in **Turbine Components Table** on page 4.

### Related Manuals

HVLP Compressor/Cart .....	309241
HVLP Turbine Spray Gun .....	309205

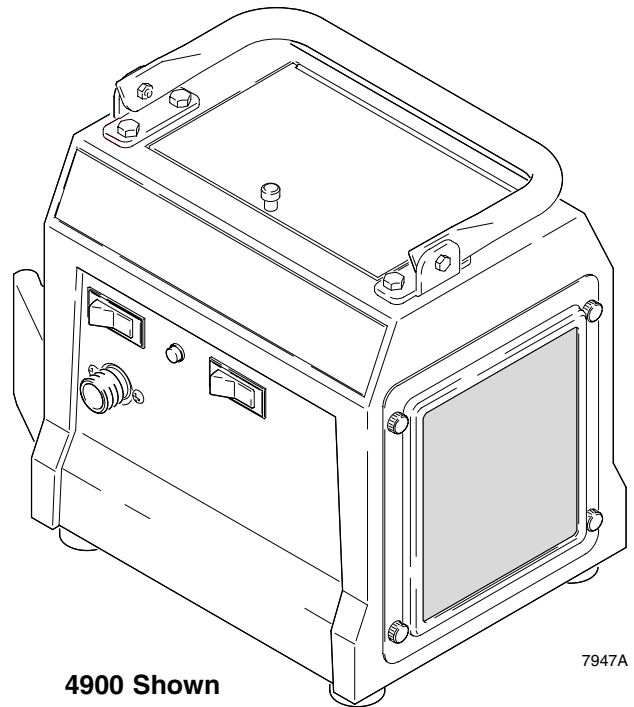

4900 Shown

7947A

# Table of Contents

Warnings .....	2
General Information .....	4
Component Identification and Function .....	5
Setup .....	6
Shutdown .....	10
Maintenance .....	11
Troubleshooting .....	13
Repair .....	14
Parts Drawing .....	16
Parts List .....	17
Accessories .....	18
Specifications .....	21
Graco Standard Warranty .....	22
Graco Phone Number .....	22

# Symbols

## Warning Symbol



This symbol alerts you to the possibility of serious injury or death if you do not follow the instructions.

## Caution Symbol



This symbol alerts you to the possibility of damage to or destruction of equipment if you do not follow the instructions.

# WARNING



## FIRE AND EXPLOSION HAZARD

Improper grounding, poor ventilation, open flames, or sparks can cause a hazardous condition and result in a fire or explosion and serious injury.

- Ground the equipment. See **Grounding** on page 6.
- If there is any static sparking or you feel an electric shock while using this equipment, **stop spraying immediately**. Do not use the equipment until you identify and correct the problem.
- Provide fresh air ventilation to avoid the buildup of flammable fumes from solvents or the fluid being sprayed.
- When flammable liquid is sprayed or used for flushing or cleaning the equipment, the turbine must be placed at least 20 feet (6.1 m) away from areas where hazardous concentrations of flammable vapors are likely to occur.
- Use additional air hose if necessary to ensure that the turbine is operated in a clean, dry, well-ventilated area.
- Never place the turbine inside a spray booth! Use this equipment outdoors or in extremely well-ventilated areas.
- Keep the spray area free of debris, including solvent, rags, and gasoline.
- Electrically disconnect all equipment in the spray area.
- Extinguish all open flames or pilot lights in the spray area.
- Do not smoke in the spray area.
- Do not turn on or off any light switch in the spray area while operating or if fumes are present.
- Do not operate a gasoline engine in the spray area.

# WARNING



INSTRUCTIONS

## EQUIPMENT MISUSE HAZARD

Equipment misuse can cause the equipment to rupture or malfunction and result in serious injury.

- This equipment is for professional use only.
- Read all instruction manuals, tags, and labels before you operate the equipment.
- Use the equipment only for its intended purpose. If you are not sure, call your Graco distributor.
- Do not alter or modify this equipment. Use only genuine Graco parts.
- Check equipment daily. Repair or replace worn or damaged parts immediately.
- Do not exceed the maximum working pressure of the lowest-rated system component.  
HVLP 2500 turbine has a working pressure of 5 psi (0.3 bar, 34 kPa).  
HVLP 3800 turbine has a working pressure of 6 psi (0.4 bar, 41 kPa).  
HVLP 4900 turbine has a working pressure of 8 psi (0.5 bar, 55 kPa).
- Use fluids and solvents that are compatible with the equipment wetted parts. See **Specifications** on page 21 for wetted parts information.
- Do not use hoses to pull equipment.
- Route hoses away from traffic areas, sharp edges, moving parts, and hot surfaces. Do not expose Graco hoses to temperatures above 82°C (180°F) or below -40°C (-40°F).
- Wear hearing protection when operating this equipment.
- Do not lift pressurized equipment.
- Comply with all applicable local, state, and national fire, electrical, and safety regulations.
- Do not point the gun at anyone or at any part of the body.
- Do not put your hand or fingers over the gun fluid nozzle.
- Do not stop or deflect leaks with your hand, body, glove, or rag.
- Do not “blow back” fluid; this is not an air spray system.
- Follow the **Pressure Relief Procedure** on page 10 if the fluid nozzle clogs and before you clean, check, or service the equipment.
- Tighten all fluid connections before you operate the equipment.
- Check the hoses, tubes, and couplings daily. Replace worn or damaged parts immediately.



## TOXIC FLUID HAZARD

Hazardous fluid or toxic fumes can cause serious injury or death if splashed in the eyes or on the skin, inhaled, or swallowed.

- Know the specific hazards of the fluid you are using.
- Store hazardous fluid in an approved container. Dispose of hazardous fluid according to all local, state, and national guidelines.
- Always wear protective eyewear, gloves, clothing and respirator as recommended by the fluid and solvent manufacturer.
- Do not use 1,1,1-trichloroethane, methylene chloride, other halogenated hydrocarbon solvents, or fluids containing such solvents in the turbine spray system, which contains aluminum and/or galvanized-coated parts. Such use could result in a serious chemical reaction, with the possibility of explosion, which could cause death, serious injury, and/or substantial property damage.

# General Information

## HVLP Turbine Sprayers

The HVLP 2500, HVLP 3800, and HVLP 4900 Turbines, compressor/cart, and spray guns can spray most coatings or finishes currently being used for automotive refinish, industrial, aerospace, marine, wood, plastic, and architectural applications.

To produce high-quality paint finishes, the spray gun typically utilizes inbound air pressure of 5 psi (0.3 bar, 34 kPa) for HVLP 2500; 6 psi (0.4 bar, 41 kPa) for HVLP 3800; and 8 psi (0.5 bar, 55 kPa) for HVLP 4900. A cone of air, produced by the gun, carries and directs the paint from the gun to the surface, minimizing overspray and increasing transfer efficiency. This enables painters to comply with new clean air laws that are designed to reduce VOC (volatile organic compounds) emissions, eases paint application by requiring fewer paint passes to obtain coverage, and saves on both material and clean-up time.

See HVLP Turbine Spray Gun manual 309205 for more information on the operation and use of the turbine spray gun.

## Unpacking Turbine

Unpack the Graco Turbine Sprayer from the shipping carton, and inspect for any possible shipping damage. If there is any damage, call your distributor.

## Turbine Configurations

Graco turbines come in the following basic configurations:

- HVLP 2500 two-stage turbine sprayer
- HVLP 3800 three-stage turbine sprayer
- HVLP 4900 four-stage turbine sprayer

## Turbine Components Table

System	Model	30-ft (9 m) Hose	Gun / Fluid Set	Extra/Fluid Sets
HVLP 2500	233421	241413	244117 non-bleeder style cup gun with 244124 (#3)	none
HVLP 3800	233422	241413	244117 non-bleeder style cup gun with 244124 (#3)	244125 (#4) 244126 (#5)
HVLP 4900	233425	241413	244117 non-bleeder style cup gun with 244124 (#3)	244123 (#2) 244125 (#4) 244126 (#5) 244127 (#6)

# Component Identification and Function

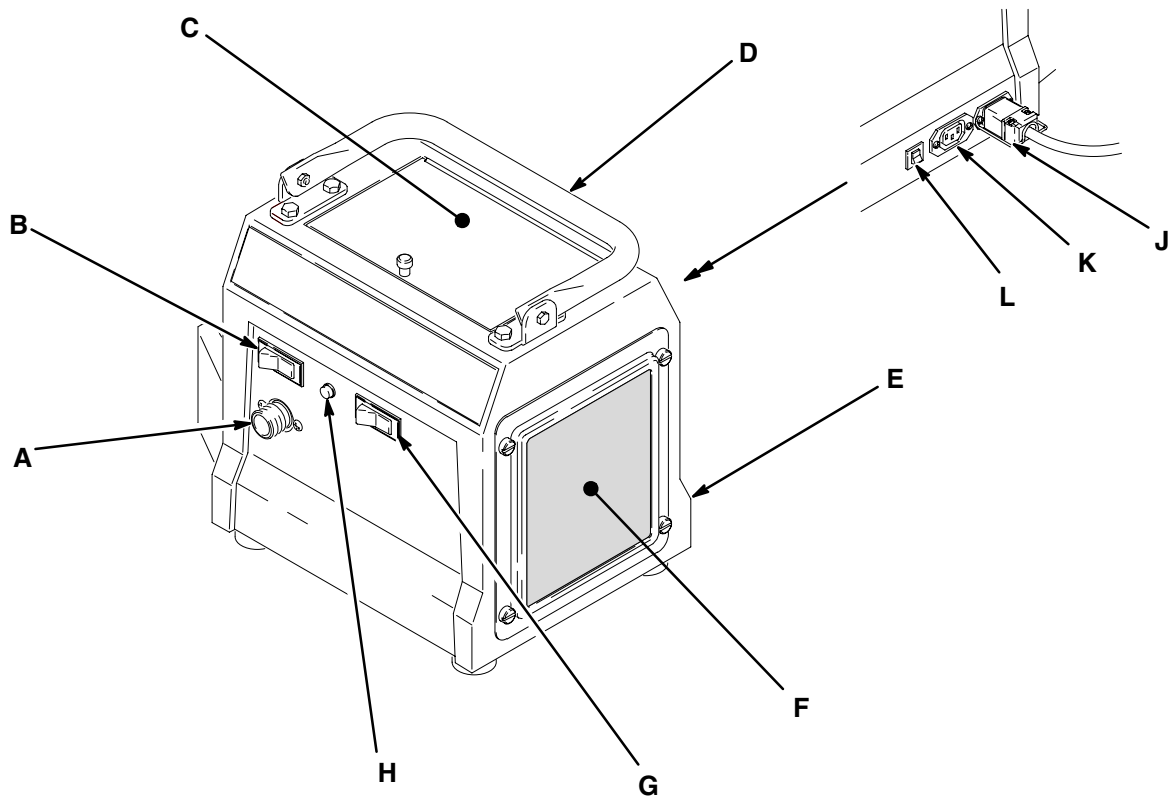

Fig. 1

7947A

<b>A</b>	Air outlet	Connection for turbine air supply to HVLP Turbine Spray Guns (HVLP 4900 units include quick connector)
<b>B</b>	Power switch	ON/OFF switch for sprayer turbine and rear outlet
<b>C</b>	Storage compartment	Provides storage for fluid set components
<b>D</b>	Turbine handle	Folds flat for minimum storage space
<b>E</b>	Turbine case	Houses air filter and provides dual air flow to motor and turbine; can be lock-mounted on compressor/cart
<b>F</b>	Air filters (pre-filter and main)	Provide filtered air for turbine spray gun and turbine motor
<b>G</b>	Two-speed switch	Allows two-speed operation of turbine sprayer motor (used on HVLP 4900 units)
<b>H</b>	Air filter indicator light	Indicates air filter performance and maintenance (used on HVLP 3800 and HVLP 4900 units)
<b>J</b>	Connector and power cord	Provides power for turbine sprayer (power cord provided with turbine)
<b>K</b>	Auxiliary power outlet	Switched power outlet for compressor/cart or other accessory
<b>L</b>	Resettable circuit breaker	Provides protection for turbine motor and cart

# Setup

## Grounding

### **⚠ WARNING**

Improper installation or alteration of the grounding plug will result in a risk of electric shock, fire, or explosion that could cause serious injury or death.

This equipment requires a 120V AC, 60 Hz, 15A circuit with a grounding receptacle. See Fig. 2.

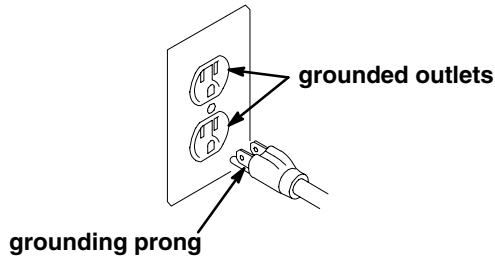

Fig. 2

Extension cord must be 3-wire, 12 AWG, 50 ft (15 m) or shorter.

Do not alter the ground prong or use an adapter.

## Setup/Use Options

HVLP Turbine Sprayers have a variety of user options. See Fig. 3.

- See compressor/cart manual 309241 for information on compressor/cart setup and operation.
- See HVLP Turbine Spray Gun manual 309205 for information on turbine spray gun setup and operation.

## Prepare the Fluid

- Always strain the fluid before you spray; this includes color, reducer, and hardeners if used.
- When using a turbine spray system, use a slower drying reducer or thinner to compensate for the faster drying time caused by the warm air of the turbine. Do not over reduce.

### **⚠ CAUTION**

The performance of the turbine sprayer varies with the viscosity of the material and the length of the hose. Keep the hose short to prevent pressure drop.

#### Paint Reduction — Automotive Type Finishes

Reduce and catalyze all paint to manufacturer's specifications. To compensate for the faster drying time of turbine systems, use a reducer that is one step slower than what is used for conventional air spray.

#### Paint Reduction — Industrial or Domestic Coatings

Reduce and catalyze all paint to manufacturer's specifications. If no reductions are given, first thoroughly mix the fluid to be sprayed. Then gradually mix in the proper reducer, testing the fluid until you have the correct spraying consistency.

To test the consistency, remove the stir stick from the thinned paint. When the paint stream running off the stir stick breaks into droplets, the first few drops should be about one second apart.

# Setup

## Connect the Fluid and Air Supply

See Fig. 3

- The HVLP compressor/cart provides the air supply for the remote pressure pot.
  - The circled letters in Fig. 3 indicate hose line connections.
1. Connect gun air supply hose (A) between turbine air outlet (B) and gun air inlet (C). DO NOT use wrench to tighten connections; hand tighten only. The HVLP 4900 turbine uses a quick connector at outlet (B). A wrench is not required for hose connection.

2. If using a spray gun cup (D):  
Connect the cup to the gun fluid inlet (E).  
If using accessory remote pressure pot (F):  
Connect fluid supply hose (G) between remote pressure pot fluid outlet (H) and gun fluid inlet (E).  
Connect pressure pot air hose (J) between pressure pot air regulator inlet (K) and the compressor/cart air outlet.

## Connect to Electric Supply

Plug turbine power cord into grounded outlet.

**NOTE:** Extension cord must be 3-wire, 12 AWG, 50 ft (15 m) or shorter.

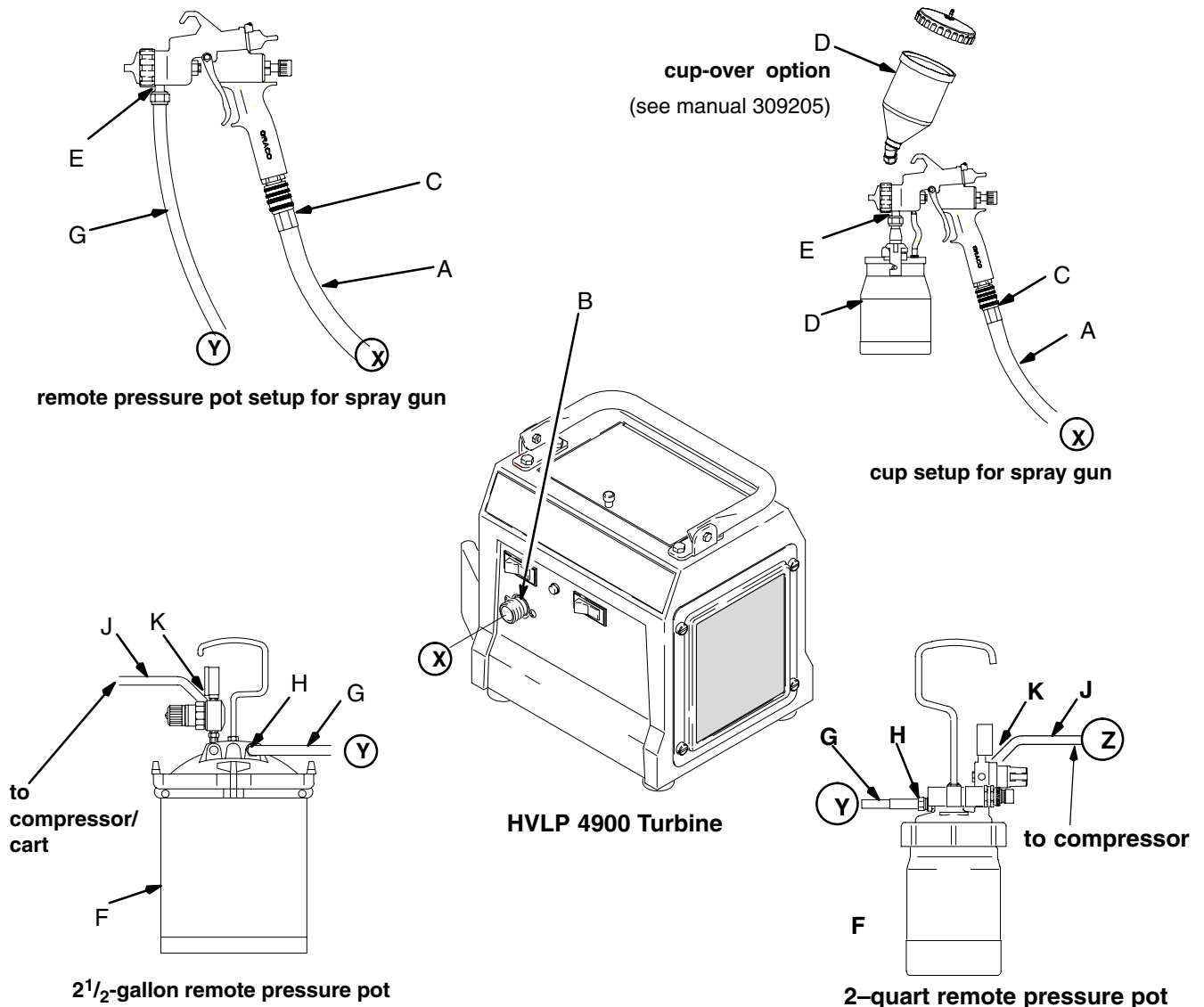

Fig. 3

4958C

# Setup

## Fill the Cup or Remote Pressure Pot

### Spray Gun Cup

#### **⚠ WARNING**

The spray gun cup is pressurized by the gun's air supply. To reduce the risk of serious injury from pressurized fluid or accidental spray from the gun, always turn off the air supply to the gun before you remove the spray gun cup.

Only fill the cup 3/4 full to help keep the air pressure tube clean, then install the cover. The under-cup cover has a latch (H) to secure it to the cup. The over-cup (J) has threads that keep the lid in place when tightened in place on the cup.

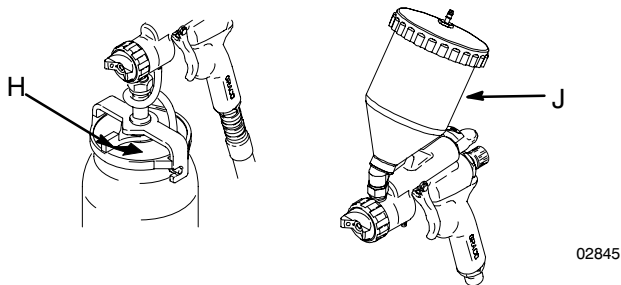

Fig. 4

### Accessory Remote Pressure Pot

#### **⚠ WARNING**

The accessory remote pressure pots remain pressurized until pressure is manually relieved. To reduce the risk of serious injury from pressurized fluid or accidental spray from the gun, always relieve pressure in the pressure pot before you loosen or remove the cover.

1. Relieve remote pressure pot pressure as follows (see Fig. 5):
  - a. Turn off air supply to pressure pot.
  - b. 2<sup>1</sup>/<sub>2</sub>-gallon remote pressure pot:  
Pull pressure relief valve ring (206c) until pressure is completely relieved.  
2-quart remote pressure pot:  
Turn **out** pressure relief knob (113) one turn.  
Wait until pressure is completely relieved before you remove cover. Close knob.

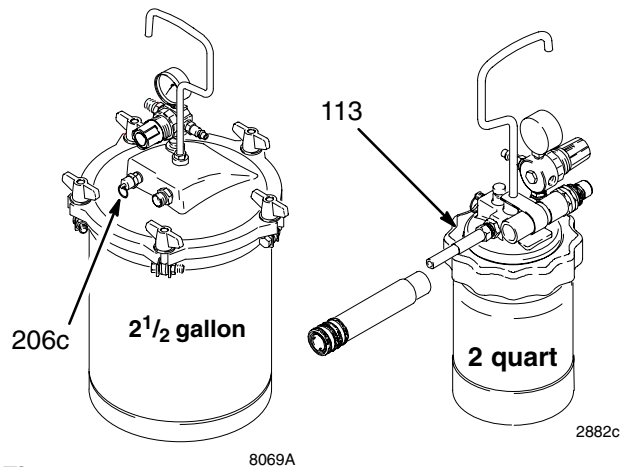

Fig. 5

2. Remove pressure pot cover and fill. Secure cover.

**NOTE:** 2-quart remote pressure pot only:  
Lightly coat the cover threads with petroleum jelly.

#### **⚠ CAUTION**

If the 2-quart remote pressure pot is accidentally tipped over or held at too great of an angle, fluid may leak into the air regulator and cause damage. Take precautions to avoid this. If fluid does get into the regulator, clean it immediately.

#### **⚠ CAUTION**

Do not tighten the pressure pot cover more than hand-tight. Excessive tightening may damage the cover gasket.

# Setup

## Prepare Surface to be Sprayed

To get proper adhesion, make sure surface is completely clean.

## Operating Turbine

### **WARNING**

Sparks can be expected in the normal operation of the turbine motor. These sparks can ignite fumes from flammable liquids, dust particles, and other flammable substances in the spray area. This can cause serious injury and property damage. Be sure to follow the precautions below:

- When flammable liquid is sprayed or used for flushing or cleaning equipment, the turbine must be placed at least 20 feet (6.1 m) away from areas where hazardous concentrations of flammable vapors are likely to occur.
- Use additional air hose if necessary to ensure that the turbine is operated in a clean, dry, well ventilated area.
- Never place the turbine inside a spray booth! Use this equipment outdoors or in extremely well ventilated areas.
- Avoid all ignition sources such as: static electricity from plastic drop cloths, open flames like pilot lights, hot objects like cigarettes, arcs from connecting or disconnecting power cords, and turning light switches on and off. Extinguish or remove all sources of ignition.

1. Turn turbine ON a few minutes before spraying to allow warm-up.

**NOTE:** When the turbine is not in use for an extended period of time, turn it off. The turbine does not shut off automatically.

2. Be sure turbine filter is clean before operating. See page 11 to check and clean filter.

**NOTE:** To adjust the spray gun pattern see the turbine gun manual.

## HVLP Compressor/Cart Cold Weather Operation

The HVLP compressor/cart uses a diaphragm compressor. A new diaphragm may be stiff in cold weather. If cold enough, the diaphragm is too stiff to allow the compressor motor to start (the unit hums). If this occurs, follow these steps:

1. Turn turbine and compressor OFF.
2. Unplug turbine from power source.
3. Pinch and remove filter by hand. Clean or replace if dirty.
4. Hand spin cooling fan on compressor for a few revolutions.
5. Reinstall filter.
6. Plug in turbine.
7. Turn turbine and compressor ON. If necessary, repeat procedure.

# Shutdown

## Pressure Relief Procedure

### **⚠ WARNING**

#### **PRESSURIZED EQUIPMENT HAZARD**

The equipment stays pressurized until pressure is manually relieved. To reduce the risk of a serious injury from pressurized fluid, accidental spray from the gun, or splashing fluid, follow the **Pressure Relief Procedure** whenever you

- Are instructed to relieve the pressure
- Stop spraying
- Check or service any of the system equipment
- Install or clean the fluid nozzles

1. Turn off air supply to gun.
2. Turn off turbine sprayer.

### **⚠ WARNING**

The turbine hose outlet may be hot. Carefully check the hose end before you remove the hose.

3. If using remote pressure pot, relieve pressure by following these steps (see Fig. 6):
  - a. Turn off air supply to pressure pot.
  - b.  $2\frac{1}{2}$ -gallon remote pressure pot:  
Pull pressure relief valve ring (206c) until pressure is completely relieved.  
2-quart remote pressure pot:  
Turn **out** pressure relief knob (113) one turn. Wait until pressure is completely relieved before you remove cover. Close knob.

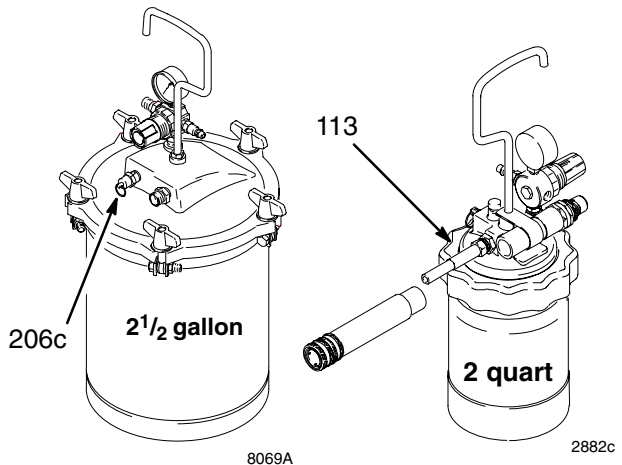

**Fig. 6**

**NOTE:** Elevate spray gun and pull trigger. This will allow fluid in fluid hose to drain back into remote pressure pot.

4. If using a spray gun cup:  
Unlatch cup cover; loosen or remove cup from cover to relieve cup pressure.
5. Clean spray gun and cup as instructed in the HVLP Turbine Spray Gun manual 309205.

# Maintenance

## Daily

The turbine systems are lifetime lubricated. The only maintenance required is filter cleaning and replacement.

The turbine filter must be clean at all times to provide sufficient air flow to cool motor and atomize the fluid. Check turbine pre-filter (22) daily for cleanliness. Check the main filter (21) weekly, minimum. Clean as necessary.

**NOTE:** To check filter, turn on turbine and place piece of paper against pre-filter. If air intake holds paper in place, filter is okay.

The HVLP 3800 and HVLP 4900 models have an air filter indicator light on the front panel. If the filter is good the light is out. If the filter is clogged or has low airflow the light will come on as in Fig. 7 below.

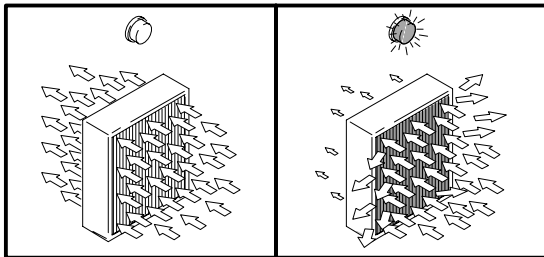

8049A

Fig. 7

### To clean filter:

1. Turn off and unplug turbine.
2. Loosen four thumbscrews (16), remove filter retainer (15) and pre-filter (22). See Fig. 8.
3. Remove main filter (21) and clean by using one of the following three methods:
  - Tap filter gently on flat surface, dirty side down.

## CAUTION

To prevent damage to filter, do not use compressed air on a wet filter.

- Direct compressed air (100 psi [7 bar, 70 kPa] maximum) through filter panel in the opposite direction of arrows on side of filter (from the clean side to the dirty side).
- Soak filter for 15 minutes in water and mild detergent. Rinse filter until clean. Air dry. Do not use compressed air on damp or wet filter.

## WARNING

To avoid damage to the turbine and possible electric shock, never install a damp filter in the turbine.

## CAUTION

To keep out dirt, do not operate the turbine sprayer without both filters installed.

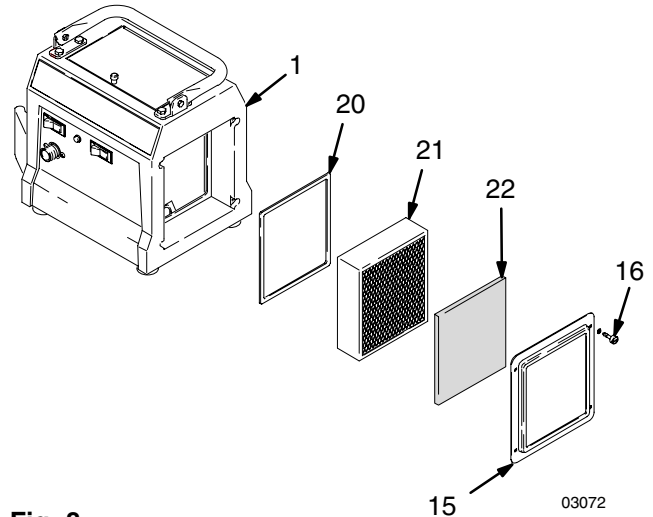

Fig. 8

03072

## Weekly

Check hose for cracks, leaks, and holes. Replace if necessary.

## Annually or Every 600 Hours, Whichever Comes First

Replace motor brushes 600 hours after turbine sprayer operation. If brushes are not replaced, motor failure will occur.

**NOTE:** It is recommended that an authorized service center perform the motor brush replacement procedure on page 14.



# Troubleshooting

PROBLEM	CAUSE	SOLUTION
No fluid delivery	No material, no remote container pressurization, hose or pickup tube clogged	Check container for material.
		Check for leaks at the container gasket (2-quart pressure pot cover or 2 <sup>1</sup> / <sub>2</sub> -gallon pressure pot wing nuts). Tighten wing nuts if loose.
		Check for air flow from male quick-disconnect at compressor outlet (should be approx. 1/4 CFM).
		Turn pressure regulator clockwise. Look for pressure on gauge. (If no pressure on gauge, check air line and fittings).
		Check hole in 2 <sup>1</sup> / <sub>2</sub> -gallon pressure pot cover under regulator or in 2-quart pressure pot cover at needle valve. Clean if necessary.
		Check for obstructions.
		Check if fluid pickup tube is unplugged. Tighten.
		Blow out and clear material hose.
Compressor not starting	Cold weather operation	See <b>HVLP Compressor/Cart Cold Weather Operation</b> on page 9.
Turbine not starting	No power	Check outlet for power. Cycle red rocker switch.
		Check that correct IEC (modular) cord is used and plugged in.
		Check circuit breaker(38). Push to reset.
Poor atomization	Dirty filter	Clean filter.
	Extension cord too long	Extension cord must be 3-wire, 12 AWG, 50 ft (15 m) or shorter.
	Hose too long	Replace with shorter hose. See <b>Accessories</b> page 20 for shorter hose and Part No.
Circuit breaker trips	Filter clogged	Clean filter and replace as necessary.
	High ambient temperature	Move turbine to cooler area.
	Excessive brush wear	Remove cover and turbine, and check for free motor rotation and for brush wear. Replace motor brushes if necessary.
	Excessive current draw	Return to authorized service center.

# Repair

## **⚠ WARNING**

Turn off turbine and unplug power for the following procedures.

### Turbine Sprayer Disassembly

1. If necessary, clean and replace filter according to maintenance procedure on page 11.
2. Place turbine upside down on work surface. Remove four cap screws (27) and bumpers (7). See Fig. 9 below and **Parts Drawing** on page 16.
3. Carefully lift unit by turbine baseplate (2) from turbine cover (1), and place upright on work surface.
4. Repair or replace items as required.
5. Reassemble turbine.

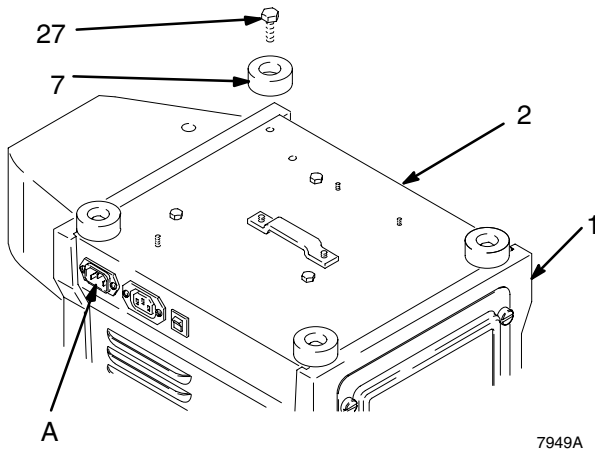

Fig. 9

### Power Cord Replacement

Replace power cord by unplugging from IEC connector (A). Install new cord. See Fig. 9

### Motor Brush Replacement

**NOTE:** It is recommended that this procedure be performed by an authorized service center.

1. Use **Turbine Sprayer Disassembly** procedure at left to take turbine apart. Use **Turbine/Motor Replacement** on page 15 to replace turbine.
2. Remove plastic fan cover.
3. Remove brushes. Check commutator for excessive wear.

**Note:** Do not install new brushes in a turbine in which the commutator has been damaged by the brush holders. A motor with this type of damage cannot be repaired.

4. Install new motor brushes using reverse order. Keep lead wires from all rotating parts and motor frame.

## **⚠ CAUTION**

Do not run the motor with the air inlet or outlet sealed off.

5. Reassemble turbine.
6. Run motor 30 to 45 minutes at half-rated voltage to seat motor brushes.

**Note:** If half-rated voltage is not available, run repaired unit in series with another turbine for 30 to 45 minutes.

# Repair

## Turbine/Motor Replacement

The HVLP 2500, HVLP 3800, and HVLP 4900 Turbines each use a different turbine/motor. See the Turbine/Motor Replacement Kits in the **Parts List** on page 17 for a listing of replacement kit parts.

See **Parts Drawing** on page 16.

1. Use **Turbine Sprayer Disassembly** procedure on page 14 to take turbine apart.
2. Remove turbine gasket (25).
3. Remove 3 screws (6).
4. Remove plate (82) and 3 spacers (83).
5. Remove turbine motor wires from spade connectors.
6. Rotate turbine (24) from outlet fitting (18) and lift up from turbine spacers (23).
7. Install new turbine gaskets (25 and 41).
8. Reassemble turbine.
9. Connect ground wire to turbine housing as required.
10. Reconnect wires according to applicable turbine. See Fig. 10, Fig. 11, or Fig. 12 schematics.

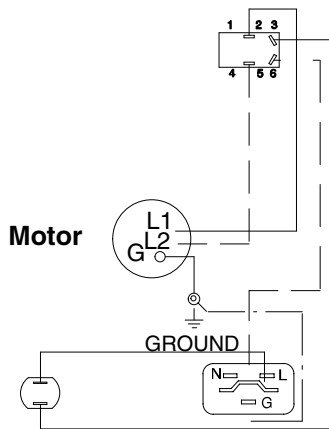

**HVLP 2500 Turbine**

**Fig. 10**

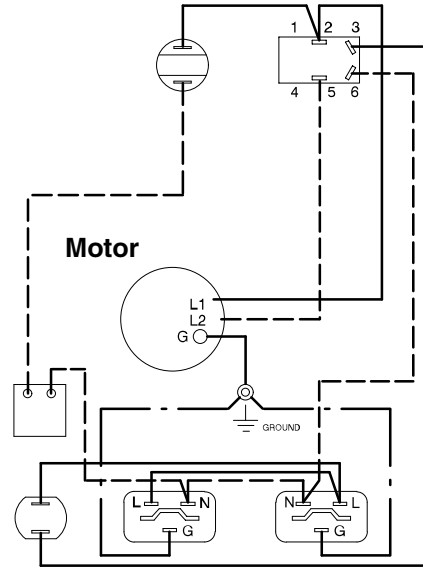

**HVLP 3800 Turbine**

**Fig. 11**

7245A

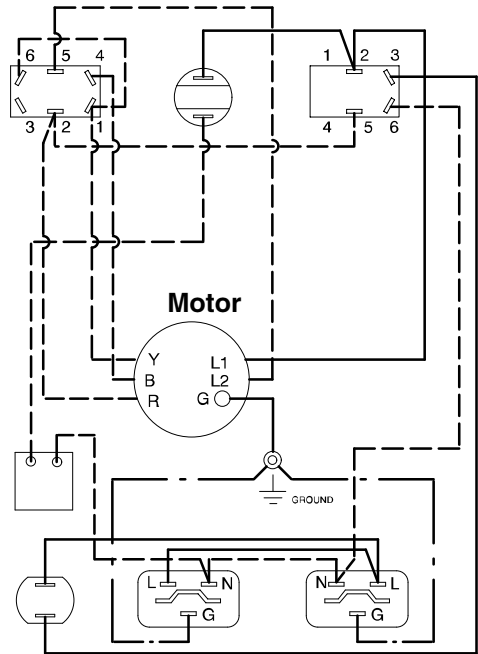

**HVLP 4900 Turbine**

**Fig. 12**

7244B

# Parts Drawing

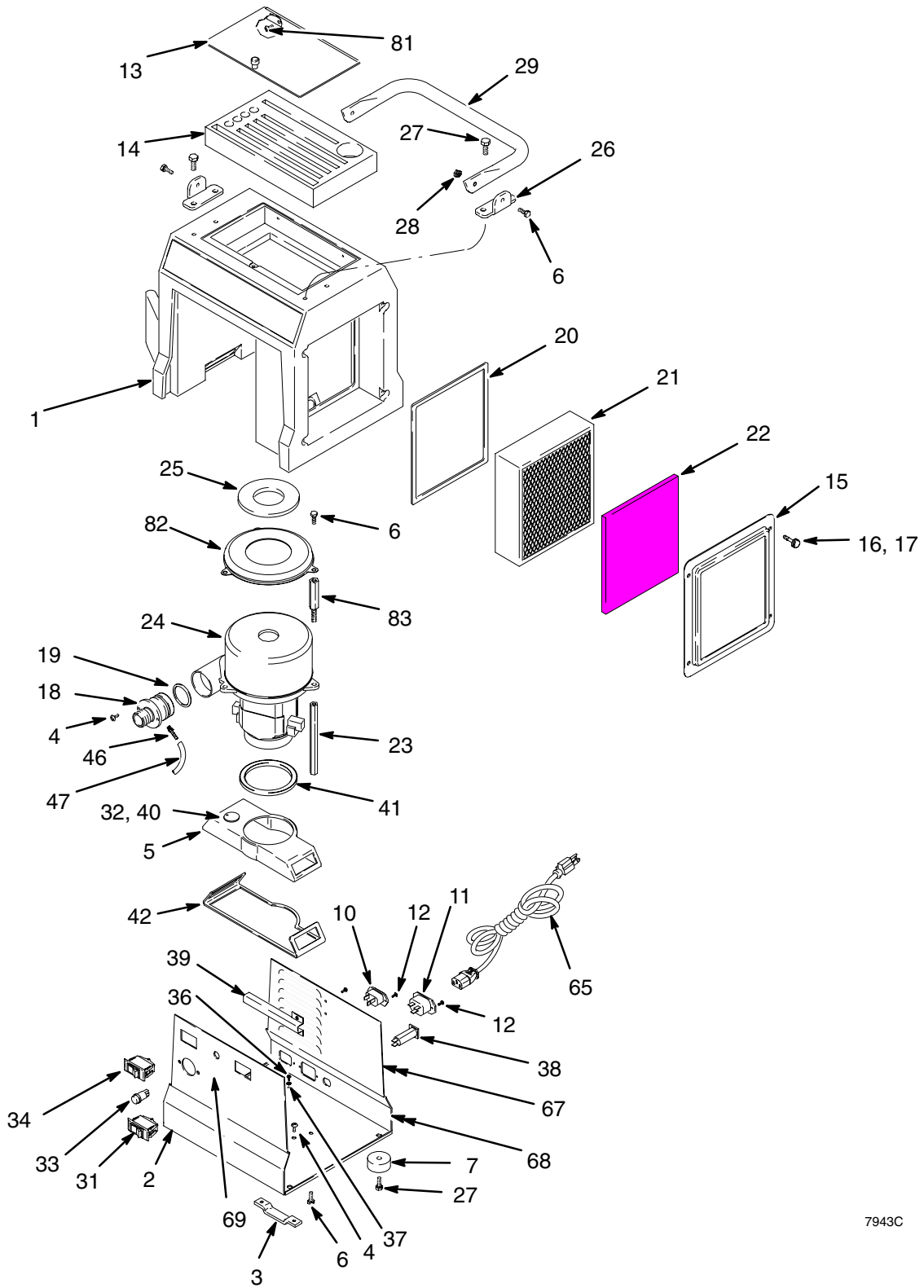

7943C

# Parts List

Ref No.	Part No.	Description	Qty	Ref No.	Part No.	Description	Qty
1	276674	COVER, turbine	1	32	114279	SENSOR, pressure (HVLP 3800 and HVLP 4900)	1
2	197111	BASE PLATE, turbine (HVLP 2500)	1	33	114280	LIGHT, indicator (HVLP 3800 and HVLP 4900)	1
	192775	BASE PLATE, turbine (HVLP 3800)	1	34	114293	SWITCH, rocker, red	1
	192774	BASE PLATE, turbine (HVLP 4900)	1	36	111593	SCREW, grounding	1
3	192786	PLATE, retaining (HVLP 3800 and HVLP 4900)	1	37	102063	WASHER, lock, external tooth	1
4	114669	SCREW, pan hd	4	38	114290	BREAKER, circuit; 8A, 120V (HVLP 2500)	1
5	192787	DUCT, turbine	1		114403	BREAKER, circuit; 15A, 120V (HVLP 3800 and HVLP 4900)	1
6	114670	SCREW, cap, hx hd	8	39	192905	PLATE, deflector (HVLP 3800 and HVLP 4900)	1
7	113817	BUMPER	4	40	193059	GASKET, sensor (HVLP 3800 and HVLP 4900)	1
10	114064	PLUG, inlet	1	41	192845	GASKET, duct	1
11	114065	PLUG, inlet, female (HVLP 3800 and HVLP 4900)	1	42	192846	GASKET, duct	1
12	114410	SCREW, pan hd, torx	6	46	114287	FITTING, barbed (HVLP 3800 and HVLP 4900)	1
13	244166	LID, tool box	1	47	192810	HOSE, air (HVLP 3800 and HVLP 4900)	1
14	197054	FOAM PAD, tool box	1	65	245202	CORD SET, 10 ft. 13 AMP, 120V (HVLP 2500 and HVLP 3800)	1
15	197057	RETAINER, filter	1		240281	CORD SET, 15 ft, 15 AMP, 120V (HVLP 4900)	1
16	192895	SCREW, captive	4	67▲	193095	LABEL, danger	1
17	158486	O-RING	4	68▲	193096	LABEL, warning	1
18	193057	FITTING, outlet (HVLP 2500)	1	69	193126	LABEL, caution	1
	192779	FITTING, outlet (HVLP 3800 and HVLP 4900)	1	75	244122	#2/4/5/6 ACCESSORY KIT (HVLP 4900) <i>Not shown</i>	1
19	156698	O-RING, buna-n	1	81	114538	SCREW, mach, pan hd	2
20	192789	GASKET, filter (HVLP 3800 and HVLP 4900)	2	82	194094	PLATE, turbine	1
21	240273	FILTER, main, paper (HVLP 3800 and HVLP 4900)	1	83		SPACER, turbine	
	244137	FILTER, main, foam (HVLP 2500)	1		194095	HVLP 2500	3
22†	240274	FILTER, pre	1		194096	HVLP 3800	3
23	193068	SPACER, turbine (HVLP 2500)	3		194097	HVLP 4900	3
	192780	SPACER, turbine (HVLP 3800 and HVLP 4900)	3				
24*	240269	TURBINE KIT, 2 stage; 120 volts (HVLP 2500)	1				
	240270	TURBINE KIT, 3 stage; 120 volts (HVLP 3800)	1				
	241122	TURBINE KIT, 4 stage; 120 volts (HVLP 4900)	1				
25	192812	GASKET, turbine (HVLP 2500)	1				
	192788	GASKET, turbine (HVLP 3800 and HVLP 4900)	1				
26	192784	BRACKET, handle	2				
27	114531	SCREW, cap, hx hd	8				
28	113414	NUT, lock	2				
29	192785	HANDLE, turbine	1				
31	114658	SWITCH, rocker (HVLP 4900)	1				

† Pre-filters are available in 5 packs. Order Part No. 240274.

\* Turbine Brush Kits are also available. Purchase separately: 240545 (for HVLP 2500), and 240546 (for HVLP 3800 and HVLP4900).

▲ Extra danger and warning labels are available for free.

# Accessories

**2<sup>1</sup>/<sub>2</sub>-Gallon (9.5 liter) PTFE® coated Pot 240045**  
*50 psi (345 kPa, 3.5 bar) Maximum Inlet Air Pressure*  
 2<sup>1</sup>/<sub>2</sub>-gallon (9.5 liter) capacity, steel tank. Includes air pressure regulator, gauge, and pressure relief valve.

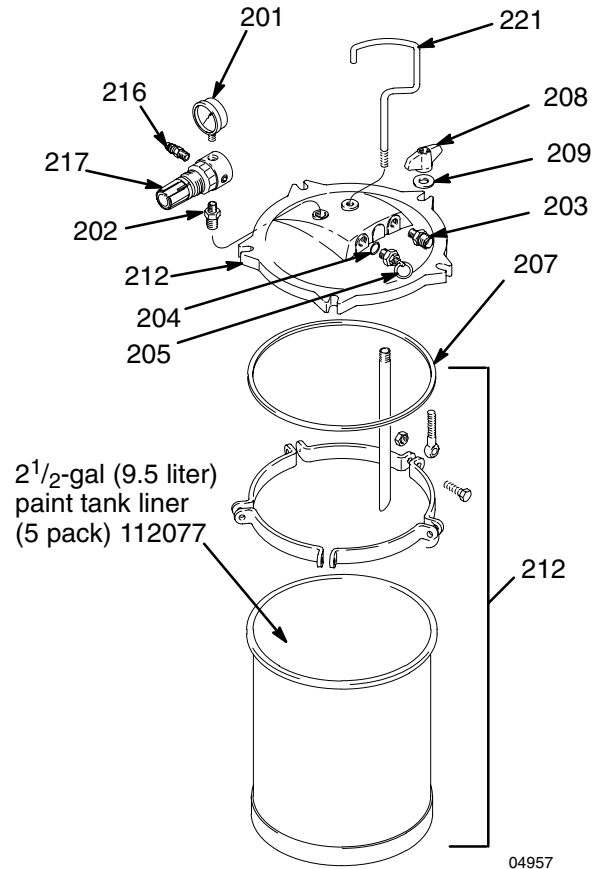

Ref. No.	Part No.	Description	Qty.
201	104655	PRESSURE GAUGE	1
202	151519	REDUCER, 1/4 to 1/8	1
203	M70687	COUPLING	1
204	M70676	O-RING	1
205	M70686	PRESSURE RELIEF VALVE	1
207	244953	GASKET, standard; polyethylene (3/kit)	1
	M70616	GASKET, standard; EPDM (optional – must order separately 1/kit)	1
	244953	GASKET, solvent resistant;	1
208	M70678	WING NUT	5
209	M70677	WASHER	5
212	244288	TANK, paint, 2 <sup>1</sup> / <sub>2</sub> -gal (9.5 liter), with PTFE coat	1
216	169969	QUICK DISCONNECT, male	1
217	104815	PRESSURE REGULATOR	1
221	M71639	HANDLE	1

# Accessories

## 2-Quart (1.9 liter) Pressure Pot 287300

50 psi (345 kPa, 3.5 bar) Maximum Inlet Air Pressure

2-quart (1.9 liter) capacity, aluminum cup.

Includes air pressure regulator, gauge, pressure relief valve, and rigid hook handle.



## WARNING

Do not use 1,1,1-trichloroethane, methylene chloride, other halogenated hydrocarbon solvents, or fluids containing such solvents in the turbine spray system, which contains aluminum and/or galvanized-coated parts. Such use could result in a serious chemical reaction, with the possibility of explosion, which could cause death, serious injury, and/or substantial property damage.

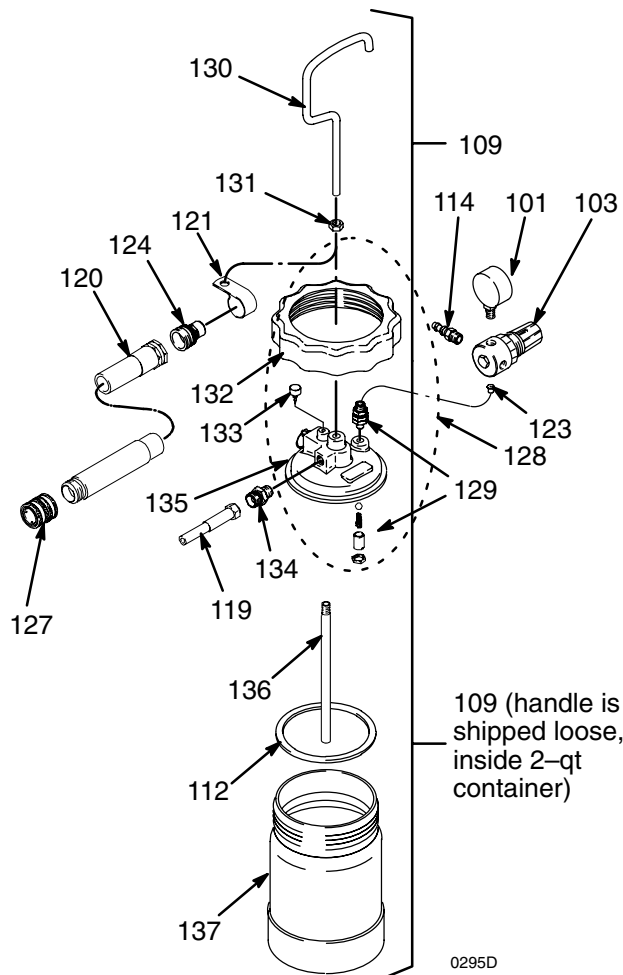

Ref. No.	Part No.	Description	Qty.
101	104655	PRESSURE GAUGE	1
103	104815	PRESSURE REGULATOR	1
109	287302	POT, 2 quart (1.9 liter), aluminum	1
112	15F346	GASKET KIT, polyethylene	1
	287404	GASKET KIT, polyethylene, 5-pack	1
114	169969	FITTING	1
119	240474	HOSE, fluid; 60 in. long; 1/4 in. ID	1
120	240482	HOSE, air; 54 in. (1.37 m) long	1
121	M70854	HOSE CLAMP	1
123	189557	RESTRICTOR	1
124	M70399	QUICK DISCONNECT, male	1
127	M70402	QUICK DISCONNECT	1
	244135	KIT, valve, duckbill (not shown)	1
	193218	STRAINER (not shown)	1
128	15D744	LID KIT, Series A	1
	15F620	LID KIT, Series B	1
129	119216	VALVE KIT, check repair, Series A	1
	15F610	VALVE KIT, check repair, Series B	1
130	119212	HANDLE, Series A	1
	15F606	HANDLE, Series B	1
131	119213	NUT, handle, Series A	1
	15F607	NUT, handle, Series B	1
132	119214	NUT, cover, Series A	1
	15F608	NUT, cover, Series B	1
133	119215	VALVE, Series A	1
	15F609	VALVE, Series B	1
134	119217	FITTING, outlet, Series A	1
	15F611	FITTING, outlet, Series B	1
135	119218	COVER Series A	1
	15F612	COVER, Series B	1
136	119220	TUBE, fluid, Series A	1
	15F613	TUBE, fluid, Series B	1
137	119221	CUP, 2 quart, Series A	1
	15F614	CUP, 2 quart, Series B	1

### NOTE:

- See HVLP Finish Systems brochure 300564 for all accessories.
- Non-silicone lubricant 111265 (4 oz.) is available for fluid seals and wear areas.

# Accessories

Standard Turbine Air Hose	
Length (ft)	Number
30	241413

Fluid Set (FS)/Spray Gun	
FS	Number
None	244115
3	244118

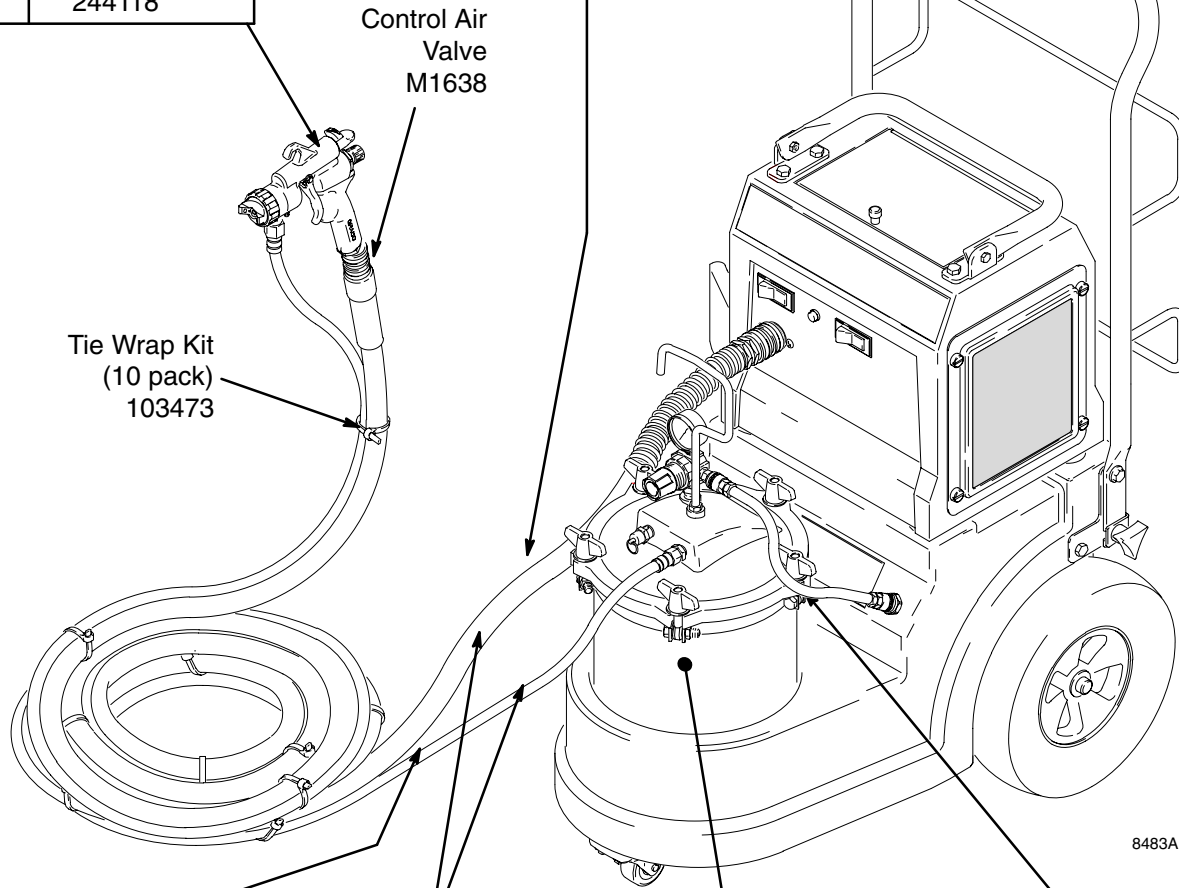

Material Hose	
Length (ft)	Number
30	240476

Air & Material Hose	
Length (ft)	Number
30	241423

Pressure Pot	
PTFE Lined	240045

Compressor Air Hose		
Pot	Length (ft)	Number
2 <sup>1</sup> / <sub>2</sub> gal	2	240074
2 qt	30	240071

**Notes:**

- See **HVLP Fine Finish Systems** brochure 300564 for all accessories.
- Non-Silicone Lubricant 111265 (4 oz) is available for fluid seals and wear areas.

# Specifications

Power requirements .....	120V AC, 50/60 Hz
Amps at 120 volts	
HVLP 2500 .....	1 phase, 7A minimum
HVLP 3800 .....	1 phase, 12A minimum
HVLP 4900 .....	1 phase, 14A minimum
Power cord (extension cord must be 3-wire, 12 AWG, 50 ft [15 m] or shorter)	
HVLP 2500 .....	No. 16 AWG, 3 wire, 10 ft
HVLP 3800 .....	No. 16 AWG, 3 wire, 10 ft
HVLP 4900 .....	No. 14 AWG, 3 wire, 15 ft
Unrestricted flow rate	
HVLP 2500 .....	58 cfm
HVLP 3800 .....	80 cfm
HVLP 4900 .....	82 cfm
Turbine stages	
HVLP 2500 .....	2
HVLP 3800 .....	3
HVLP 4900 .....	4
Maximum turbine hose length	
HVLP 2500 .....	40 ft (12 m)
HVLP 3800 .....	60 ft (18 m)
HVLP 4900 .....	60 ft (18 m)
Cup volume .....	1 quart (0.95 liter)
Wetted parts	
Bare spray gun .....	stainless steel, brass, PTFE, hard-coated aluminum
Spray gun cup .....	aluminum, polyethylene
2-quart (1.9 liter) accessory remote pressure pot .....	aluminum, brass, polyethylene
2 <sup>1</sup> / <sub>2</sub> -gallon (9.5 liter) accessory remote pressure pot .....	steel with solvent-resistant finish, EPDM gasket (standard)
Turbine shipping weight	
HVLP 2500 .....	32 lb (14.5 kg)
HVLP 3800 .....	34 lb (15.4 kg)
HVLP 4900 .....	36 lb (16.3 kg)
Turbine diameter .....	5.7 in (144.78 mm)
Sound level per ISO 3744	
Sound power level .....	89.0 dB(A)
Sound pressure level .....	78.0 dB(A)

# Graco Standard Warranty

Graco warrants all equipment manufactured by Graco and bearing its name to be free from defects in material and workmanship on the date of sale to the original purchaser for use. With the exception of any special, extended, or limited warranty published by Graco, Graco will, for a period of twelve months from the date of sale, repair or replace any part of the equipment determined by Graco to be defective. This warranty applies only when the equipment is installed, operated and maintained in accordance with Graco's written recommendations.

This warranty does not cover, and Graco shall not be liable for general wear and tear, or any malfunction, damage or wear caused by faulty installation, misapplication, abrasion, corrosion, inadequate or improper maintenance, negligence, accident, tampering, or substitution of non-Graco component parts. Nor shall Graco be liable for malfunction, damage or wear caused by the incompatibility of Graco equipment with structures, accessories, equipment or materials not supplied by Graco, or the improper design, manufacture, installation, operation or maintenance of structures, accessories, equipment or materials not supplied by Graco.

This warranty is conditioned upon the prepaid return of the equipment claimed to be defective to an authorized Graco distributor for verification of the claimed defect. If the claimed defect is verified, Graco will repair or replace free of charge any defective parts. The equipment will be returned to the original purchaser transportation prepaid. If inspection of the equipment does not disclose any defect in material or workmanship, repairs will be made at a reasonable charge, which charges may include the costs of parts, labor, and transportation.

**THIS WARRANTY IS EXCLUSIVE, AND IS IN LIEU OF ANY OTHER WARRANTIES, EXPRESS OR IMPLIED, INCLUDING BUT NOT LIMITED TO WARRANTY OF MERCHANTABILITY OR WARRANTY OF FITNESS FOR A PARTICULAR PURPOSE.**

Graco's sole obligation and buyer's sole remedy for any breach of warranty shall be as set forth above. The buyer agrees that no other remedy (including, but not limited to, incidental or consequential damages for lost profits, lost sales, injury to person or property, or any other incidental or consequential loss) shall be available. Any action for breach of warranty must be brought within two (2) years of the date of sale.

Graco makes no warranty, and disclaims all implied warranties of merchantability and fitness for a particular purpose in connection with accessories, equipment, materials or components sold but not manufactured by Graco. These items sold, but not manufactured by Graco (such as electric motors, switches, hose, etc.), are subject to the warranty, if any, of their manufacturer. Graco will provide purchaser with reasonable assistance in making any claim for breach of these warranties.

In no event will Graco be liable for indirect, incidental, special or consequential damages resulting from Graco supplying equipment hereunder, or the furnishing, performance, or use of any products or other goods sold hereto, whether due to a breach of contract, breach of warranty, the negligence of Graco, or otherwise.

## **FOR GRACO CANADA CUSTOMERS**

The parties acknowledge that they have required that the present document, as well as all documents, notices and legal proceedings entered into, given or instituted pursuant hereto or relating directly or indirectly hereto, be drawn up in English. Les parties reconnaissent avoir convenu que la rédaction du présente document sera en Anglais, ainsi que tous documents, avis et procédures judiciaires exécutés, donnés ou intentés à la suite de ou en rapport, directement ou indirectement, avec les procédures concernées.

# Graco Information

**TO PLACE AN ORDER**, contact your Graco distributor, or call **1-800-690-2894** to identify the nearest distributor.

*All written and visual data contained in this document reflect the latest product information available at the time of publication.*

*Graco reserves the right to make changes at any time without notice.*

MM 309240

**Graco Headquarters:** Minneapolis

**International Offices:** Belgium, China, Japan, Korea

**GRACO INC. P.O. BOX 1441 MINNEAPOLIS, MN 55440-1441**

**www.graco.com**

PRINTED IN USA 309240H

10/200 Rev. 06/2005