

INSTRUCTIONS – INSTRUCTIONS – INSTRUÇÕES – INSTRUCCIONES



309091

Rev. B

Contractor Airless Spray Gun; Pistolet pulvérisateur sans air Contractor; Pistola de pulverização a alta pressão Contractor; Pistola de pulverización sin aire Contractor

*3600 psi (248 bar, 24.8 MPa) Maximum Working Pressure
Pression de service maximum 3600 psi (248 bar, 24.8 MPa)
Pressão máxima de trabalho de 3600 psi (248 bar, 24.8 MPa)
Presión máxima de funcionamiento de 3600 psi (248 bar, 24.8 MPa)*

243282, A

HandTite™ Tip Guard, 517 RAC™ 5 SwitchTip™; 2–finger trigger
Garde HandTite™, buse 517 RAC™ 5 SwitchTip™; gâchette de 2 doigts
Protecção HandTite™, bico 517 RAC™ 5 SwitchTip™; gatilho de 2 dedos
Protección HandTite™, boquilla 517 RAC™ 5 SwitchTip™ gatillo de 2 dedos

235990, D

Standard (nonreversing) Dripless™ Tip Guard; 4–finger trigger. No spray tip; order separately.
Norme (non réversible) Garde–buse Dripless™; gâchette de 4 doigts. No buse; commande séparément.
Padrão (nao reversível) Protecção de bico Dripless™; gatilho de 4 dedos. No bico; ordem separada.
Estándar (no reversible) Protección de boquilla Dripless™; gatillo de 4 dedos. No boquilla; orden por separado.

217593, E

Standard (nonreversing) Dripless™ Tip Guard. No tip; order separately.
Norme (non réversible) Garde–buse Dripless™. No buse; commande séparément.
Padrão (nao reversível) Protecção de bico Dripless™. No bico; ordem separada.
Estándar (no reversible) Protección de boquilla Dripless™. No boquilla; orden por separado.

824950, A

HandTite™ Tip Guard, 517 RAC™ 5 SwitchTip™; 2–finger trigger
Garde HandTite™, buse 517 RAC™ 5 SwitchTip™; gâchette de 2 doigts
Protecção HandTite™, bico 517 RAC™ 5 SwitchTip™; gatilho de 2 dedos
Protección HandTite™, boquilla 517 RAC™ 5 SwitchTip™ gatillo de 2 dedos

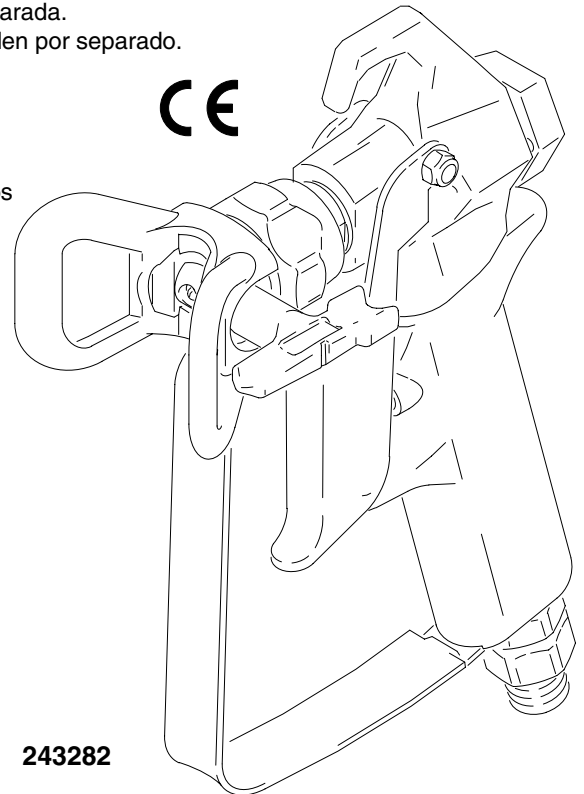

243282

All models not available in all countries.
Tous les modèles ne sont pas disponibles dans tous les pays.
Nem todos os modelos se encontram disponíveis em todos os países.
Hay modelos que no se distribuyen en todos los países.

9643A

GRACO INC. P.O. BOX 1441 MINNEAPOLIS, MN 55440–1441

©COPYRIGHT 1999, GRACO INC.

Graco Inc. is registered to I.S. EN ISO 9001

⚠ WARNING

Fire and explosion hazard: Solvent and paint fumes can ignite or explode.

To help prevent a fire and explosion:

- Use in an extremely well ventilated area.
- Eliminate all ignition sources; such as pilot lights, cigarettes and static arcs from plastic drop cloths. Do not plug or unplug power cords or turn lights on or off in spray area.
- Ground Sprayer, object being sprayed, paint and solvent pails.
- Hold gun firmly to side of grounded pail when triggering into pail.
- Use only conductive airless paint hose.
- Do not use 1,1,1-trichloroethane, methylene chloride, other halogenated hydrocarbon solvents or fluids containing such solvents in pressurized aluminum equipment. Such use could result in a chemical reaction, with the possibility of explosion.

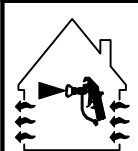

⚠ MISE EN GARDE

Risques d'incendie et d'explosion: Les vapeurs de solvant et de peinture peuvent s'enflammer ou causer une explosion.

Pour empêcher tout incendie et explosion:

- N'utiliser ce matériel que dans des locaux extrêmement bien aérés.
- Éliminer toutes les sources de feu, comme les veilleuses, cigarettes et les arcs statiques provenant de bâches plastique. Ne pas brancher ou débrancher de cordon électrique ou allumer ou éteindre la lumière sur un site de pulvérisation.
- Raccorder le pulvérisateur, l'objet à peindre et les seaux de peinture et de solvant à la terre.
- Appuyer le pistolet contre le côté du seau mis à la terre quand on pulvérise dans le seau.
- N'utiliser que des flexibles de peinture conducteurs sans air.
- Ne jamais utiliser de trichloroéthane-1,1,1, de chlorure de méthylène, d'autres solvants à base d'hydrocarbures halogénés ni de fluides contenant de tels solvants dans une unité sous pression en aluminium. Cela pourrait provoquer une réaction chimique avec risque d'explosion.

Fluid injection and high pressure hazard: High pressure spray or leaks can inject fluid into the body.

To help prevent injection, always:

- Engage trigger safety latch when not spraying.
- Keep clear of nozzle and leaks.
- Never spray without a tip guard.
- Do **PRESSURE RELIEF** if you stop spraying or begin servicing sprayer.
- Do not use components rated less than sprayer *Maximum Working Pressure*.
- Never allow children to use this unit.
- Brace yourself; gun may recoil when triggered.

If high pressure fluid pierces your skin, the injury might look like "just a cut". But it is a serious wound! Get immediate medical attention.



Risques d'injection, haute pression danger: Une pulvérisation ou des fuites à haute pression peuvent provoquer une injection de produit dans le corps.

Pour éviter toute injection, toujours:

- Verrouiller la gâchette à chaque arrêt de la pulvérisation.
- Se tenir à l'écart de la buse et des fuites.
- Ne jamais se servir du pistolet pour pulvériser sans une protection de buse.
- Effectuer une **DÉCOMPRESSION** à chaque arrêt de la pulvérisation ou avant tout entretien.
- Ne pas utiliser d'éléments prévus pour une pression inférieure à la *pression de service maximum du pulvérisateur*.
- Ne jamais permettre à des enfants d'utiliser cet appareil.
- Croisillon vous-même; le pistolet peut reculer une fois déclenché.

Si du liquide sous haute pression est injecté sous la peau, la blessure peut avoir l'apparence "d'une simple coupure", mais c'est en fait une blessure sérieuse! Consulter un médecin immédiatement.

⚠ ADVERTÊNCIA

Perigo de incêndio e explosão: os solventes e os vapores da pintura poderão explodir ou incendiar.

Para ajudar a evitar incêndio e explosão:

- Utilize em áreas extremamente bem ventiladas.
- Elimine todas as fontes de ignição, tais como luzes piloto, cigarros e arcos estáticos de plásticos de protecção. Não ligue nem desligue os cabos de alimentação nem as luzes numa área de pulverização.
- Ponha em contacto com a terra o pulverizador, o objecto a ser pulverizado e os baldes de tinta e de solventes.
- Segure a pistola firmemente de encontro ao lado do balde em contacto com a terra, quando estiver a descarregar para dentro do mesmo.
- Utilize apenas tubos flexíveis condutores para pintura a alta pressão.
- Não utilize 1,1,1-tricloroetano, cloreto de metileno, outros solventes de hidrocarbonetos halogenados ou líquidos contendo tais solventes em equipamento de alumínio pressurizado. Tal utilização poderá resultar numa reacção química, com possibilidade de explosão.

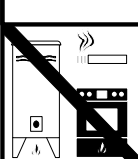

⚠ ADVERTENCIA

Peligro de incendio y explosión: Los vapores de disolvente o de pintura pueden incendiarse o explotar.

Para ayudar a evitar que se produzca un incendio o una explosión:

- Utilizar en una zona extremadamente bien ventilada.
- Elimine toda fuente de ignición; como las luces piloto, los cigarrillos y los arcos estáticos procedentes de cubiertas de plástico. No enchufe ni desenchufe aparatos en las tomas de corrientes de la zona de pulverización.
- Conecte a tierra el pulverizador, el objeto que esté pintando y los cubos de disolvente.
- Sujete firmemente la pistola contra el lado de un recipiente conectado a tierra mientras dispara la pistola hacia el interior del mismo.
- Utilice únicamente mangueras de pintura sin aire, conductoras eléctricamente.
- No utilice nunca 1,1,1-tricloroetano, cloruro de metileno, otros disolventes de hidrocarburo halogenado o fluidos que contengan tales disolventes en una bomba a presión de aluminio. El uso de estas sustancias puede provocar una seria reacción química con riesgos de explosión.

Perigo de injeção de líquidos e de alta pressão: a pulverização ou fugas a alta pressão podem injectar líquido no corpo.

Para ajudar a prevenir a injeção de líquido, faça sempre o seguinte:

- Engate o trinco de segurança do gatilho quando não estiver a pulverizar.
- Mantenha-se afastado de bocais e locais de fuga.
- Nunca pulverize sem protecção no bico.
- **ALIVIE A PRESSÃO** se parar de pulverizar e antes de iniciar a manutenção do pulverizador.
- Não utilize componentes com uma classificação inferior à do pulverizador *Pressão Máxima de Trabalho*.
- Nunca permita que crianças utilizem esta unidade.
- Cinta você mesmo; o pistola pode recoil quando provodado.

Se o líquido a alta pressão penetrar na pele, o ferimento poderá parecer "simplesmente um corte". Mas é um ferimento grave! Procure imediatamente assistência médica.



Peligro de inyección de fluido y de alta presión: La pulverización o las fugas a alta presión pueden inyectar fluido en el cuerpo.

Para ayudar a evitar la inyección, siempre:

- Enganche el seguro del gatillo cuando no esté pulverizando.
- Manténgase alejado de la boquilla y de las fugas.
- No pulverice sin una protección en la boquilla.
- Siga el procedimiento de **DESCOMPRESIÓN** si deja de pulverizar o al comenzar la revisión del pulverizador.
- No use componentes cuya presión nominal sea menor que la *Presión máxima de funcionamiento del pulverizador*.
- Nunca permita que los niños utilicen esta unidad.
- Paréntesis usted mismo; la pistola puede retroceso cuando está accionado.

Si el fluido a alta presión penetra la piel, la herida puede parecer "un simple corte". ¡Pero se trata de una herida grave! Consiga inmediatamente atención médica.

CONTROLS / COMMANDES / CONTROLOS / CONTROLES

Trigger Lock / Verrouillage gâchette / Fecho do gatilho / Seguro del gatillo



Needle Adjustment
Réglage du pointeau
Regulação da agulha
Ajuste de la aguja

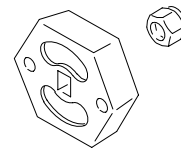

Tip Guard / Garde-buse /
Proteção do bico /
Protección de la boquilla

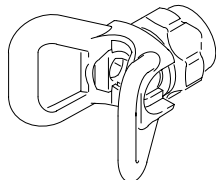

Tip / Buse / Bico / Boquilla

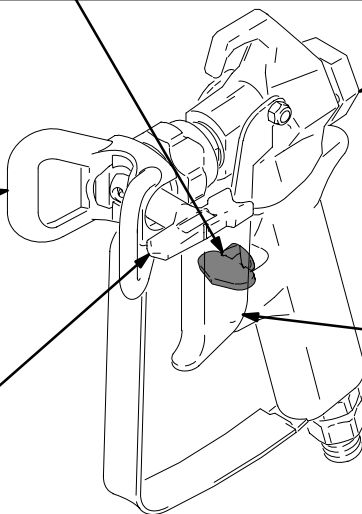
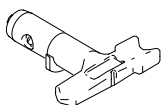

Trigger / Gâchette
Gatilho / Gatillo

PRESSURE RELIEF / DÉCOMPRESSION / ALÍVIO DE PRESSÃO / DESCOMPRESIÓN



Follow 1–5 when you stop spraying.
Effectuer les opérations 1–5 lors d'un arrêt de la pulvérisation.
Siga os passos de 1–5 quando parar de pulverizar.
Cuando deje de pulverizar, siga los pasos 1–5.

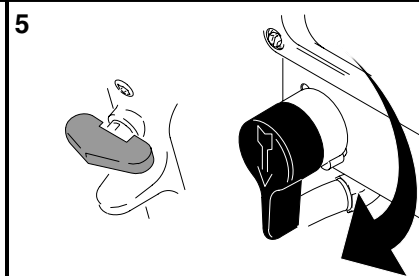
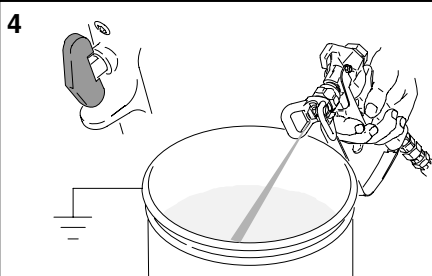
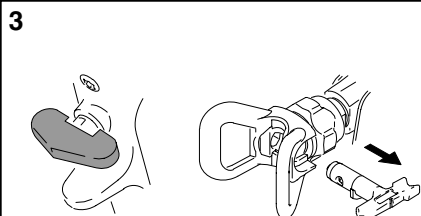
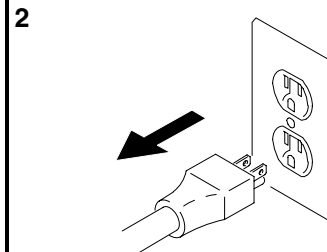
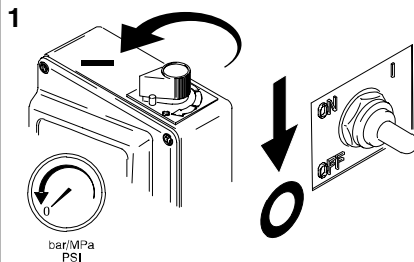

INSTALLATION / INSTALLATION / INSTALAÇÃO / INSTALACIÓN

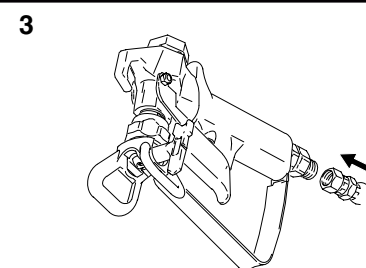
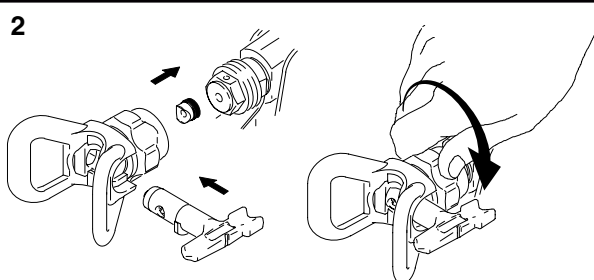
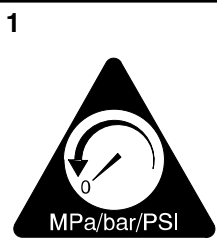

**ALIGN SPRAY / ALIGNER LE JET / ALINHAR A PULVERIZAÇÃO /
ALINEAR PULVERIZACIÓN**

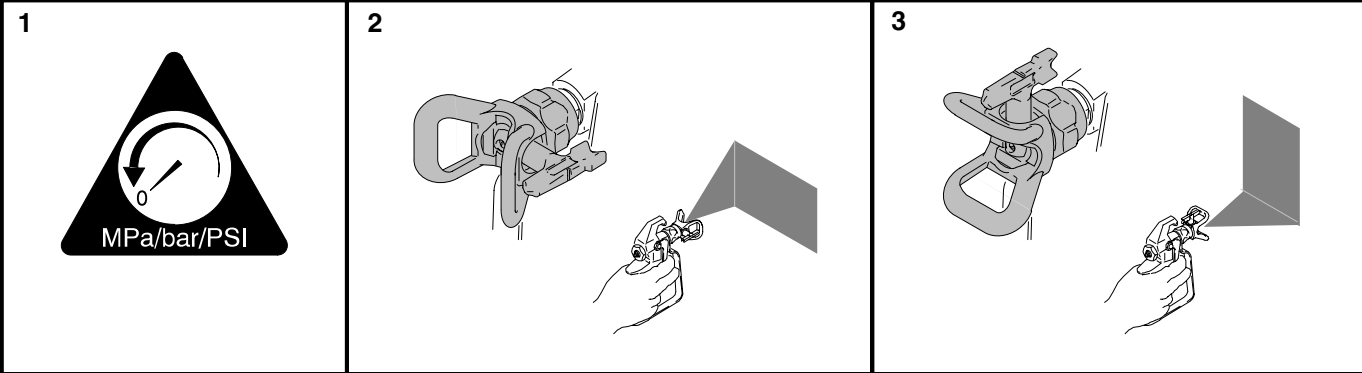

**ADJUST SPRAY / RÉGLER LE JET / REGULAR A PULVERIZAÇÃO /
AJUSTAR PULVERIZACIÓN**

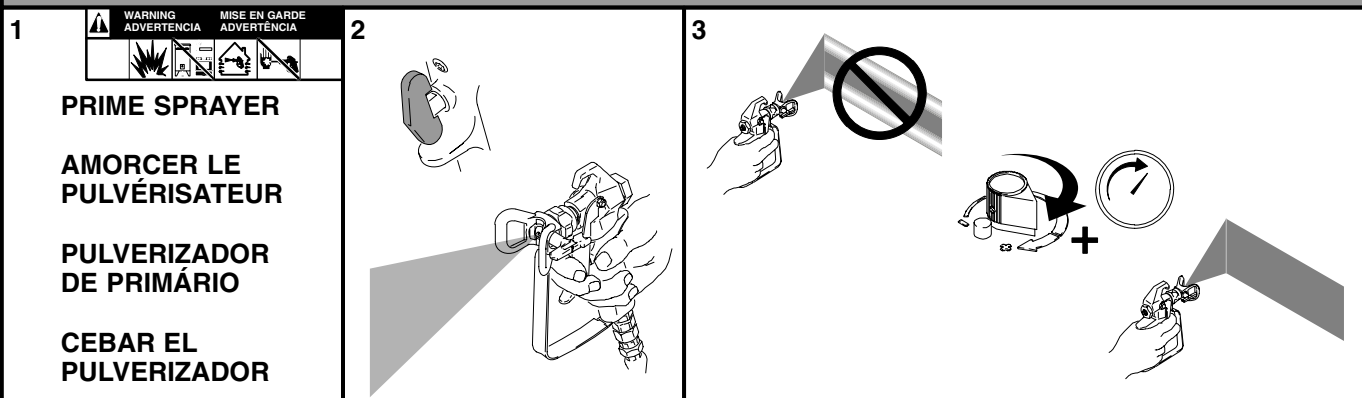

CLEAR CLOG / DÉBOUCHER LA BUSE / ELIMINAR A OBSTRUÇÃO / ELIMINAR OBSTRUCCIÓN

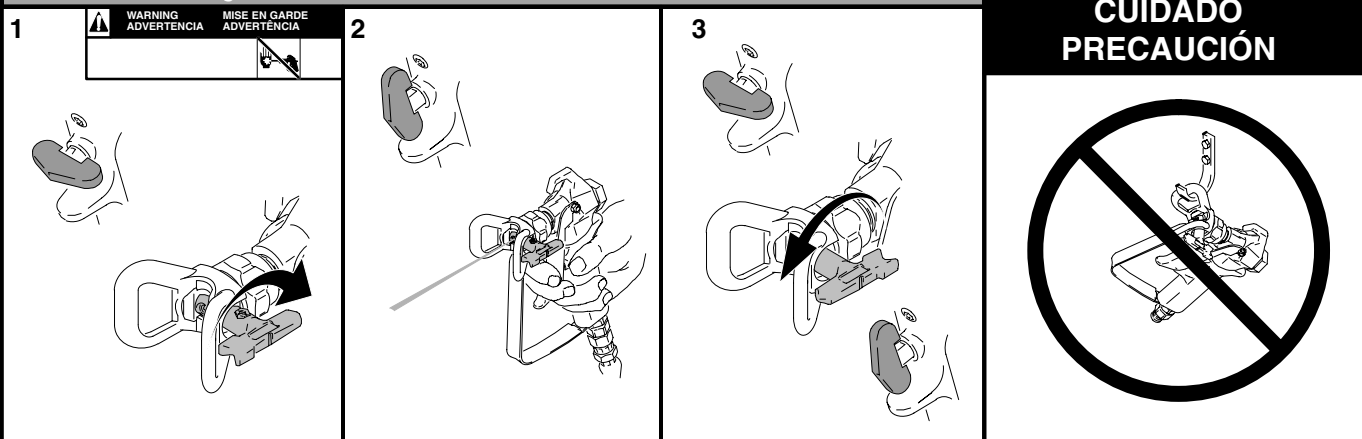

**REPLACE NEEDLE / REMPLACER LE POINTEAU / SUBSTITUIR AGULHA /
REEMPLAZAR AGUJA** 

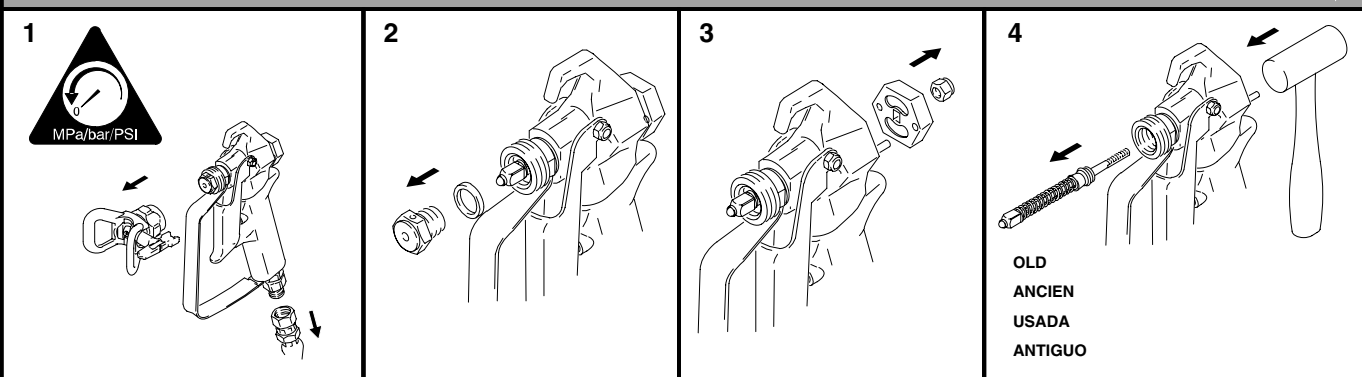

REPLACE NEEDLE / REMPLACER LE POINTEAU / SUBSTITUIR AGULHA / REEMPLAZAR AGUJA

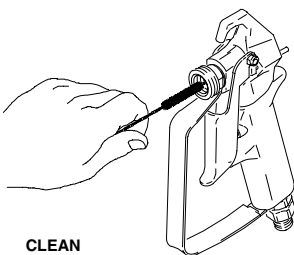
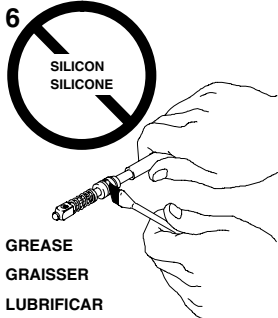
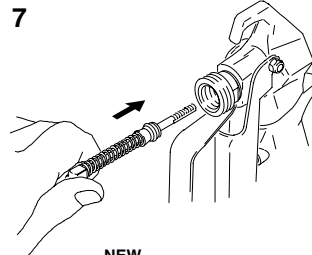
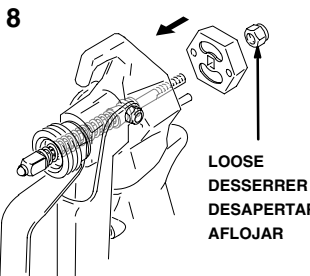

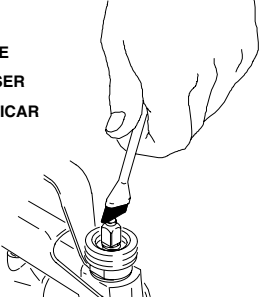
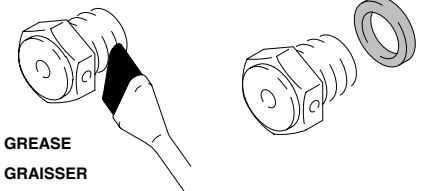
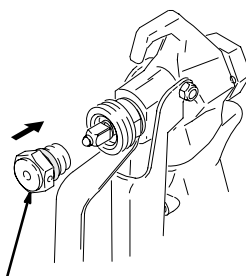
<p>5</p>  <p>CLEAN NETTOYER LIMPAR LIMPIAR</p>	<p>6</p>  <p>SILICON SILICONE</p> <p>GREASE GRAISSER LUBRIFICAR GRASA</p>	<p>7</p>  <p>NEW NOUVEAU NOVA NUEVO</p>	<p>8</p>  <p>LOOSE DESSERRER DESAPERTAR AFLOJAR</p>
--	---	--	---

<p>9</p>  <p>GREASE GRAISSER LUBRIFICAR GRASA</p>	<p>10</p>  <p>GREASE GRAISSER LUBRIFICAR ENGRASAR</p>	<p>11</p>  <p>26–32 ft-lb / 26–32 pés-lb / 35–43 N·m</p>
---	--	--

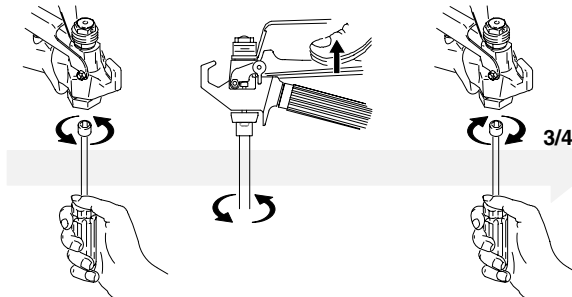
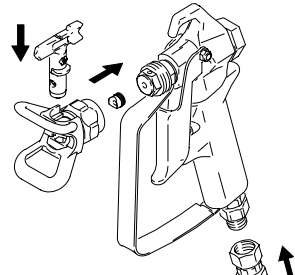

ADJUST NEEDLE / RÉGLER LE POINTEAU/REGULAR AGULHA / AJUSTAR AGUJA

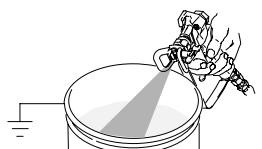
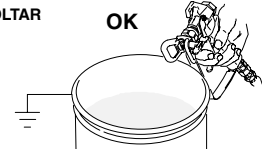
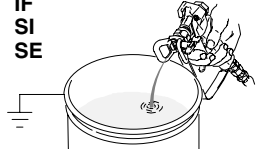
<p>1</p>  <p>3/4</p>	<p>2</p> 	<p>PRIME SPRAYER</p> <p>AMORCER LE PULVÉRISATEUR</p> <p>PULVERIZADOR DE PRIMÁRIO</p> <p>CEBAR EL PULVERIZADOR</p>
--	--	---

✓ Trigger / ✓ Gâchette / ✓ Gatilho / ✓ Gatillo

<p>5</p> <p>SQUEEZE APPUYER APERTAR APRETAR</p> 	<p>6</p> <p>RELEASE RELÂCHER SOLTAR SOLTAR</p> <p>OK</p> 	<p>IF SI SE</p>  <p>THEN ALORS ENTÃO DESPUÉS</p>  <p>MPa/bar/PSI</p> <p>ADJUST NEEDLE RÉGLER LE POINTEAU REGULAR AGULHA REGULAR AGULHA</p>
--	---	--

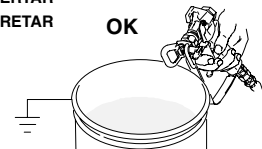
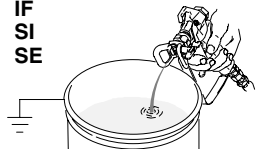
✓ Trigger Lock / ✓ Verrouillage gâchette / ✓ Fecho do gatilho / ✓ Seguro del gatillo

<p>7</p> 	<p>8</p> <p>SQUEEZE APPUYER APERTAR APRETAR</p> <p>OK</p> 	<p>IF SI SE</p>  <p>THEN ALORS ENTÃO DESPUÉS</p>  <p>MPa/bar/PSI</p> <p>ADJUST NEEDLE RÉGLER LE POINTEAU REGULAR AGULHA REGULAR AGULHA</p>
---	--	--

Parts / Pièces / Peças / Piezas

Model 243282, Series A
Includes items 1 and 4 to 42

Model 235990, Series D
Includes items 1 to 39

Model 217593, Series E
Includes items 1 to 39

Model 824950, Series A
Includes items 1 and 4 to 42

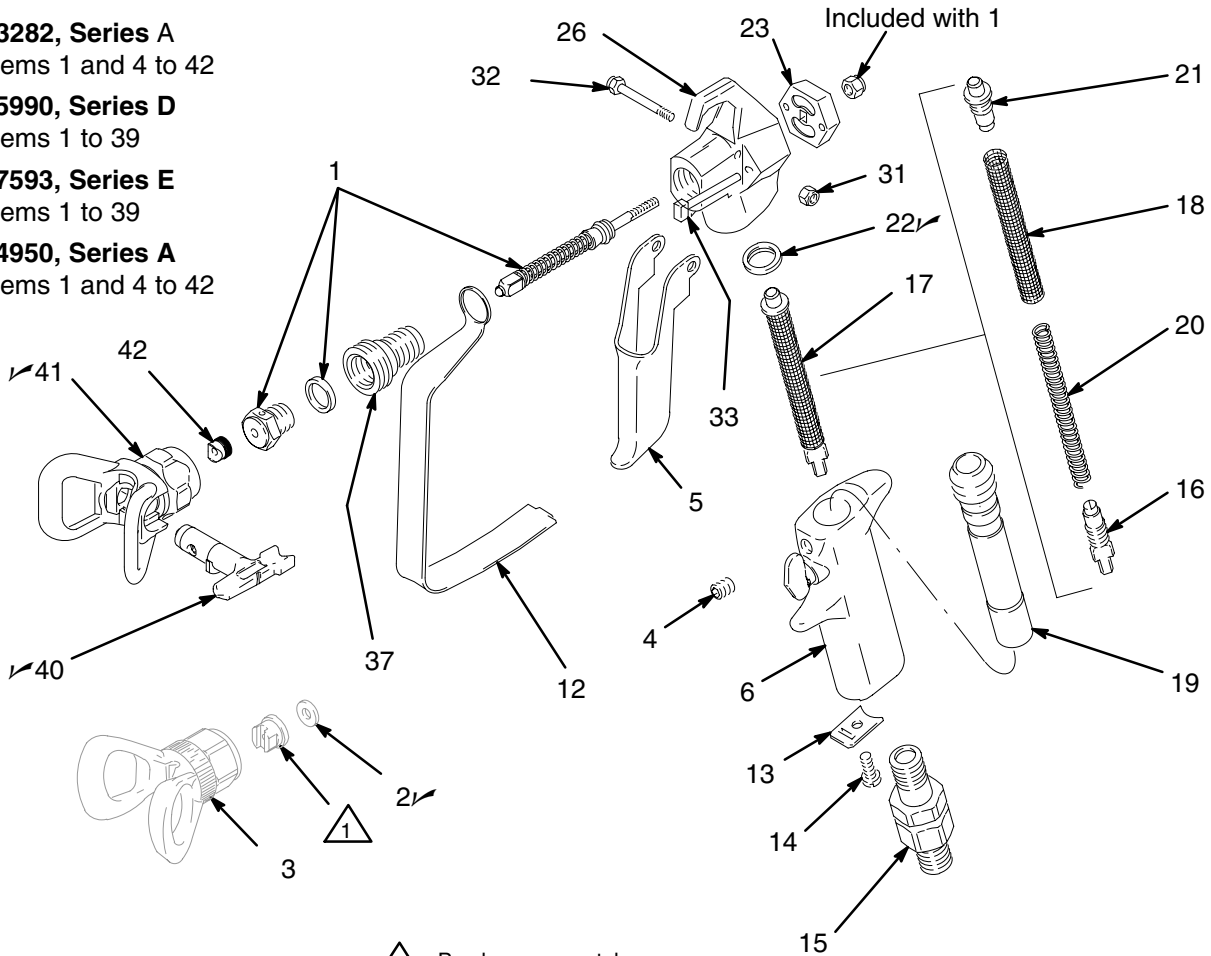

 Purchase separately

9644A

Ref. No.	Part No.	Description	Qty.	Ref. No.	Part No.	Description	Qty.
1	218070	NEEDLE-DIFFUSER/SEAT KIT	1	18a	179732	STRAINER ELEMENT	
2✓	166969	GASKET, tip (used with flat tips only)	1			(optional 100 mesh)	1
3	220251	TIP GUARD	1	19	179721	FLUID TUBE	1
4	100421	SETSCREW, soc hd, 5/16-18 x 3/8"	1	20	179763	SPRING	1
5	179734	2 FINGER TRIGGER (standard)	1	21	179722	SPRING RETAINER (color coded blue)	
5a	179943	4 FINGER TRIGGER				(for standard 50 mesh filter)	1
		(Model 235990 only)	1	21a	179957	SPRING RETAINER (color coded orange)	
6	218643	GUN HANDLE ASSEMBLY				(for optional 100 mesh filter)	1
		includes replaceable items 4, 13, 14	1	22✓	179733	GASKET	1
10▲	172479	INSTRUCTION TAG	1	23	191244	END CAP	1
11▲	179761	WARNING TAG	1	26	179718	FLUID HOUSING	1
12	195495	TRIGGER GUARD	1	31	105334	LOCKNUT; M4 x 0.7 thread	1
13	179730	GUARD RETAINER	1	32	177538	TRIGGER STUD	1
14	109575	SCREW, 8-32 x 5/16"	1	33	179737	ACTUATOR PIN	2
15	218021	SWIVEL	1	37	195419	NEEDLE HOUSING	1
16	179750	SPRING RETAINER	1	39▲	222385	WARNING CARD (not shown)	1
17✓	218131	FLUID FILTER ASSEMBLY		40✓	286517	RAC 5 SWITCHTIP TIP, SZ 517	1
		(standard 50 mesh) includes		41✓	243161	HANDTITE™ TIP GUARD	1
		replaceable items 16, 18, 20, 21	1	42	243281	OneSeal™ (5 pack)	1
17a	218133	FLUID FILTER ASSEMBLY					
		(optional 100 mesh) includes					
		replaceable items 16, 18a, 20, 21a	1				
18	179731	STRAINER ELEMENT					
		(standard 50 mesh)	1				

▲ Replacement Danger and Warning labels, tags and cards are available at no cost.

✓ Keep these spare parts on hand to reduce down time.

Graco Standard Warranty

Garantie Graco standard

Garantia Standard da Graco

Garantía estándar de Graco

Graco warrants all equipment referenced in this document which is manufactured by Graco and bearing its name to be free from defects in material and workmanship on the date of sale by an authorized Graco distributor to the original purchaser for use. With the exception of any special, extended, or limited warranty published by Graco, Graco will, for a period of twelve months from the date of sale, repair or replace any part of the equipment determined by Graco to be defective. This warranty applies only when the equipment is installed, operated and maintained in accordance with Graco's written recommendations.

This warranty does not cover, and Graco shall not be liable for general wear and tear, or any malfunction, damage or wear caused by faulty installation, misapplication, abrasion, corrosion, inadequate or improper maintenance, negligence, accident, tampering, or substitution of non-Graco component parts. Nor shall Graco be liable for malfunction, damage or wear caused by the incompatibility of Graco equipment with structures, accessories, equipment or materials not supplied by Graco, or the improper design, manufacture, installation, operation or maintenance of structures, accessories, equipment or materials not supplied by Graco.

This warranty is conditioned upon the prepaid return of the equipment claimed to be defective to an authorized Graco distributor for verification of the claimed defect. If the claimed defect is verified, Graco will repair or replace free of charge any defective parts. The equipment will be returned to the original purchaser transportation prepaid. If inspection of the equipment does not disclose any defect in material or workmanship, repairs will be made at a reasonable charge, which charges may include the costs of parts, labor, and transportation.

THIS WARRANTY IS EXCLUSIVE, AND IS IN LIEU OF ANY OTHER WARRANTIES, EXPRESS OR IMPLIED, INCLUDING BUT NOT LIMITED TO WARRANTY OF MERCHANTABILITY OR WARRANTY OF FITNESS FOR A PARTICULAR PURPOSE.

Graco's sole obligation and buyer's sole remedy for any breach of warranty shall be as set forth above. The buyer agrees that no other remedy (including, but not limited to, incidental or consequential damages for lost profits, lost sales, injury to person or property, or any other incidental or consequential loss) shall be available. Any action for breach of warranty must be brought within two (2) years of the date of sale.

GRACO MAKES NO WARRANTY, AND DISCLAIMS ALL IMPLIED WARRANTIES OF MERCHANTABILITY AND FITNESS FOR A PARTICULAR PURPOSE, IN CONNECTION WITH ACCESSORIES, EQUIPMENT, MATERIALS OR COMPONENTS SOLD BUT NOT MANUFACTURED BY GRACO. These items sold, but not manufactured by Graco (such as electric motors, switches, hose, etc.), are subject to the warranty, if any, of their manufacturer. Graco will provide purchaser with reasonable assistance in making any claim for breach of these warranties.

In no event will Graco be liable for indirect, incidental, special or consequential damages resulting from Graco supplying equipment hereunder, or the furnishing, performance, or use of any products or other goods sold hereto, whether due to a breach of contract, breach of warranty, the negligence of Graco, or otherwise.

FOR GRACO BRAZILIAN/CANADIAN/COLUMBIAN CUSTOMERS

The Parties acknowledge that they have required that the present document, as well as all documents, notices and legal proceedings entered into, given or instituted pursuant hereto or relating directly or indirectly hereto, be drawn up in English.

À L'ATTENTION DES CLIENTS BRÉSILIENS/CANADIENS/COLOMBIENS DE GRACO

Les parties reconnaissent avoir convenu que la rédaction du présente document sera en Anglais, ainsi que tous documents, avis et procédures judiciaires exécutés, donnés ou intentés à la suite de ou en rapport, directement ou indirectement, avec les procédures concernées.

PARA CLIENTES BRASILEIROS/CANADIANOS/COLOMBIANOS DA GRACO

As partes confirmam que solicitaram que o presente documento, assim como todos os demais documentos, notas e processos legais inseridos, atribuídos ou instituídos de acordo com o mesmo ou relacionados directa ou indirectamente com este documento, fossem redigidos em inglês.

PARA LOS CLIENTES EN BRASIL/CANADÁ/COLOMBIA

Las partes reconocen haber convenido que el presente documento, así como todos los documentos, notificaciones y procedimientos judiciales emprendidos, presentados o establecidos que tengan que ver con estas garantías directa o indirectamente, estarán redactados en inglés.

ADDITIONAL WARRANTY COVERAGE / AVENANT DE GARANTIE COBERTURA DE GARANTIA ADICIONAL / COBERTURA ADICIONAL DE LA GARANTÍA

Graco does provide extended warranty and wear warranty for products described in the "Graco Contractor Equipment Warranty Program".

Graco accorde une garantie étendue et se porte garant des produits décrits dans le "Programme de garantie d'équipements des fournisseurs Graco".

A Graco fornece prorrogação de garantia e garantia de desgaste para os produtos descritos no "Graco Contractor Equipment Warranty Program" (Programa de garantia de equipamento Contractor da Graco).

Graco proporciona una garantía extendida y una garantía que cubre el desgaste de los productos descritos en el "Programa de Garantía del Equipo Contractor de Graco".

Technical Data

Category	Data
Maximum fluid working pressure	3600 psi (248 bar, 24.8 MPa)
Fluid orifice size	0.125 in. (3.18 mm)
Wetted parts	Stainless steel, Polyethylene, Polyurethane, Nylon, PTFE
Weight	18 oz (510 g)
Inlet	1/4 npsm(m) swivel
Maximum material temperature	120°F (50°C)
* Sound pressure level	78 dBa
* Sound power level	87 dBa

* Measured while spraying waterbase paint – gravity 1.36 through a 517 tip at 3000 psi (207 bar, 20.7 MPa) per ISO 3744.

PTFE® is a registered trademark of the DuPont Co.

TO PLACE AN ORDER OR FOR SERVICE, contact your Graco distributor,
or call 1–800–690–2894 to identify the nearest distributor.

POUR PASSER COMMANDE OU DEMANDER UNE PRESTATION D'ENTRETIEN, contactez votre distributeur Graco
PARA EFECTUAR ENCOMENDAS OU PARA ASSISTÊNCIA TÉCNICA, contacte o seu distribuidor da Graco
PARA REMITIR UN PEDIDO O SOLICITAR SERVICIO, póngase en contacto con el distribuidor de Graco.

All written and visual data contained in this document reflects the latest product information available at the time of publication. Graco reserves the right to make changes at any time without notice.

Toutes les données écrites et visuelles figurant dans ce document reflètent les toutes dernières informations disponibles au moment de sa publication. Graco se réserve le droit de procéder à des modifications à tout moment sans avis préalable.

Todos os dados escritos e visuais contidos neste documento reflectem as mais recentes informações sobre o produto disponíveis na altura da publicação. A Graco reserva-se o direito de efectuar alterações em qualquer momento sem aviso prévio.

Todos los datos, escritos y visuales, contenidos en este documento reflejan la información más reciente sobre el producto disponible en el momento de su publicación, Graco se reserva el derecho de realizar cambios en cualquier momento, sin previo aviso.

Sales Offices: Minneapolis, Detroit
Foreign Offices: Belgium, Korea, Hong Kong, Japan
Bureaux des ventes: Minneapolis, Detroit
Bureaux à l'étranger: Belgique, Corée, Hong-Kong, Japon
Escritórios de Vendas: Minneapolis, Detroit
Escritórios estrangeiros: Bélgica, Coreia, Hong Kong, Japão
Oficinas de vendas: Minneapolis, Detroit
Oficinas en el extranjero: Bélgica, Corea, Hong Kong, Japón

GRACO INC. P.O. BOX 1441 MINNEAPOLIS, MN 55440–1441

<http://www.graco.com>

PRINTED IN USA 309091 11/1999, Revised 11/2000
IMPRIMÉ AUX É.-U. 309091 11/1999, Revisé 11/2000
IMPRESO EN EE.UU. 309091 11/1999, Revisado 11/2000
IMPRESSO NOS EUA 309091 11/1999, Revisado 11/2000