

Instructions—Parts List



Husky™ / Twistork™ Package

308656F
ENG

Used to mix and transfer fluids in bung-type, 55-gallon (200-liter) drums. For professional use only.

100 psi (0.69 MPa, 6.9 bar) Maximum Air Input Pressure

Model 238859, Series B

Husky/Twistork package with polypropylene pump

Model 238860, Series B

Husky/Twistork package with acetal pump



Important Safety Instructions

Read all warnings and instructions in this manual.
Save these instructions.

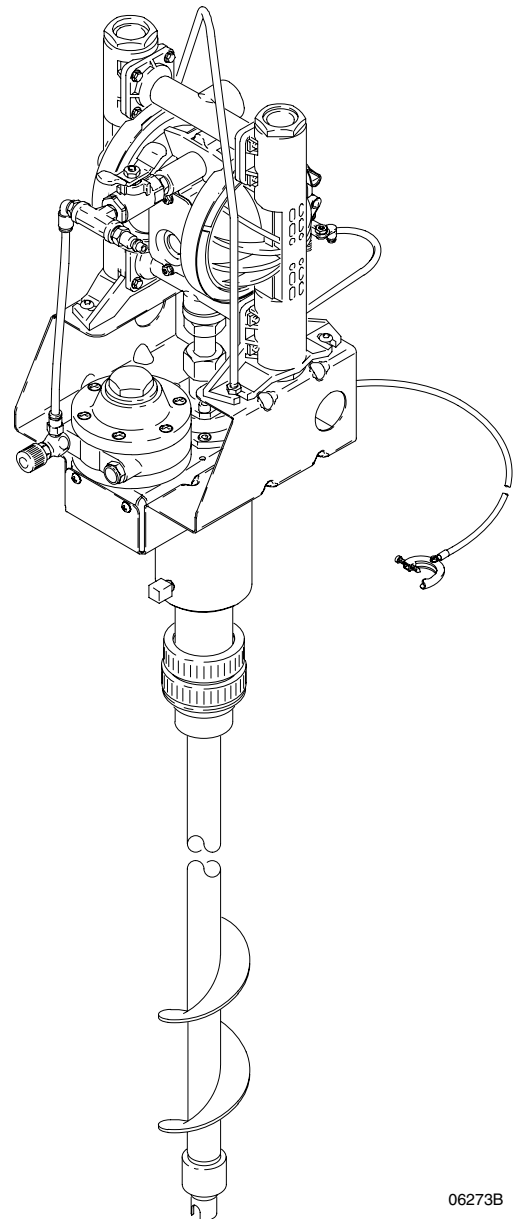

Table of Contents

Warnings	2
Installation	4
Operation	4
Service	5
Parts List	5
Parts Drawing	6
Technical Data	7
Dimensional Drawing	7
Graco Standard Warranty	8
Graco Information	8

06273B



HO03

PROVEN QUALITY. LEADING TECHNOLOGY.

Symbols

Warning Symbol



This symbol alerts you to the possibility of serious injury or death if you do not follow the instructions.

Caution Symbol



This symbol alerts you to the possibility of damage to or destruction of equipment if you do not follow the instructions.

! WARNING



INSTRUCTIONS

EQUIPMENT MISUSE HAZARD

Equipment misuse can cause the equipment to rupture or malfunction and result in serious injury.

- This equipment is for professional use only.
- Read all instruction manuals, tags, and labels before operating the equipment.
- Use the equipment only for its intended purpose. If you are not sure, call your Graco distributor.
- Do not alter or modify this equipment.
- Check equipment daily. Repair or replace worn or damaged parts immediately.
- Do not exceed the maximum working pressure of the lowest rated component in your system. This equipment has a **100 psi (7 bar) maximum working pressure**.
- Use fluids and solvents that are compatible with the equipment wetted parts. Refer to the **Technical Data** section of all equipment manuals. Read the fluid and solvent manufacturer's warnings.
- Always wear protective eyewear, gloves, clothing, and respirator as recommended by the fluid and solvent manufacturer.
- Comply with all applicable local, state, and national fire, electrical, and safety regulations.
- Route hoses away from traffic areas, sharp edges, moving parts, and hot surfaces. Do not expose hoses to temperatures above 180° F (82° C) or below -40° F (-40° C).
- Do not lift pressurized equipment.
- The lift hook on this system is for lifting the pump and agitator only. **Do not** try to lift the drum by connecting the unit to the drum and lifting up on the lift hook.

WARNING



FIRE AND EXPLOSION HAZARD

Improper grounding, poor ventilation, open flames, or sparks can cause a hazardous condition and result in a fire or explosion and serious injury.

- Ground all equipment and the equipment being dispensed to. Refer to **Grounding** on page 4.
- If you are dispensing non-conductive flammable fluids, you must use the unit with the acetal pump, which is conductive.
- If there is any static sparking or you feel an electric shock while using this equipment, **stop dispensing immediately**. Do not use the equipment until you identify and correct the problem.
- Do not use kerosene or other flammable solvents or combustible gases to flush the agitator motor. For information about flushing the pump, see the **Technical Data** section of the pump manual.
- Provide fresh air ventilation to avoid the buildup of flammable fumes from solvents or the fluid being dispensed.
- Keep the dispensing area free of debris, including solvent, rags, and gasoline.
- Do not smoke in the dispensing area.
- Extinguish all open flames and pilot lights in the dispensing area.
- The fluid hose you attach to this system must be electrically conductive and must meet the fluid pressure requirements of the system.



MOVING PARTS HAZARD

Moving parts, such as the rotating blades of the agitator, can pinch or amputate your fingers or other body parts and can cause splashing in the eyes or on the skin.

- Keep clear of all moving parts when starting or operating the agitator.
- Always shut off the agitator and disconnect the air line before you remove the agitator from the drum or check or repair any part of the agitator.





TOXIC FLUID HAZARD

Hazardous fluids or toxic fumes can cause serious injury or death if splashed in the eyes or on the skin, swallowed, or inhaled. When flushing the air motor or pump, keep your face away from the exhaust port.

Installation

Grounding

 **WARNING**

**FIRE AND EXPLOSION HAZARD**

This unit must be grounded. Before you operate it, ground the system as explained in this section. Also, read **Fire and Explosion Hazard** on page 3. For further grounding information, read the **Grounding** section in the pump manual and the agitator manual.

Proper grounding is an essential part of maintaining a safe system.

To reduce the risk of static sparking, and all electrically conductive objects or devices in the dispensing area **must** be properly grounded. Check your local electrical code for detailed grounding instructions for your area and type of equipment.

To ground the dispenser, connect the end of the ground wire (4) to a true earth ground. See the **Parts Drawing** on page 6.

NOTE: This unit is shipped with the ground wire attached to the grounding strip on the pump and to the grounding lug on the agitator. The ground wire must always be attached to these two places during use.

 **WARNING**

TIPPING HAZARD

This unit should be used **only** on flat, level surfaces. Uneven or slanted surfaces could cause the drum to tip over.

Do not transfer drums with the unit mounted in the bung hole. When the unit is mounted in the bung hole, the center of gravity is too high for stability during transfer and could tip over.

If possible, before you tighten the bung connection, rotate the unit so the agitator air motor is as close as possible to the center of the drum. That will improve the center of gravity and reduce the tipping hazard.

Operation

Pressure Relief Procedure

 **WARNING**

PRESSURIZED EQUIPMENT HAZARD

The equipment stays pressurized until pressure is manually relieved. To reduce the risk of serious injury from pressurized fluid, accidental spray, or splashing fluid, follow this procedure whenever you:

- Are instructed to relieve pressure
- Stop dispensing
- Check, clean, or service any system equipment
- Install or clean dispensing nozzles

1. Shut off the air to the pump.
2. Open the dispensing valve to relieve all fluid pressure, and have a container ready to catch the drainage.

See the **Parts Drawing** on page 6.

- **Flush the dispenser before first use.**

NOTE: The pump was tested with lightweight oil, which is left in the fluid passages to protect parts. To avoid contaminating your fluid with oil, flush the pump with a compatible solvent before using the equipment.

- You must ensure that the agitator is stopped any time it is not contained in the drum. See **Moving Parts Hazard** on page 3.
- Operate the pump by opening and closing the ball valve (17). Operate the agitator by adjusting the needle valve. *See the pump manual and the agitator manual for detailed operating instructions.*

NOTE: For stopping the pump and agitator in emergencies, disconnect the air line from the quick-disconnect air line fitting (14).

- When you lift the unit from the bung-mounted position, lift the unit with the aid of an overhead hoist hooked up to the lift hook (9).

Service

See the individual component instruction manuals for service instructions specific to the agitator and the pump.

CAUTION

Before operation, tighten the bung connection firmly by hand, and check it periodically during operation for tightness. See the **Parts Drawing** on page 6.

Parts List

Husky/Twistork Package, Model 238859, Series B

Includes items 1, 3 through 20

Husky/Twistork Package, Model 238860, Series B

Includes items 2 through 20

Ref No.	Part No.	Description	Qty.	Ref No.	Part No.	Description	Qty.
1	241565	PUMP, Husky 515, polypropylene <i>See manual 308981.</i>	1	10	100011	NUT, wing	4
2	241564	PUMP, Husky 515, acetal <i>See manual 308981.</i>	1	11	110755	WASHER	4
3	236629	AGITATOR, Twistork <i>See manual 308345.</i>	1	12	111570	BOLT, carriage	2
4	222011	WIRE, ground	1	13	100015	NUT, hex	2
5	191755	BRACKET	1	14	169970	FITTING, air line	1
6	113575	O-RING, packing	1	15	108638	TEE, pipe	1
7	191742	NUT, suction tube	1	16	110937	ELBOW, male	1
8	191566	UNION, suction tube	1	17	110223	BALL VALVE, vented	1
9	191756	HOOK, lift	1	18	156971	NIPPLE, short	1
				19	113208	FITTING, tube	1
				20	054172	TUBE, air	9 in.

Parts Drawing

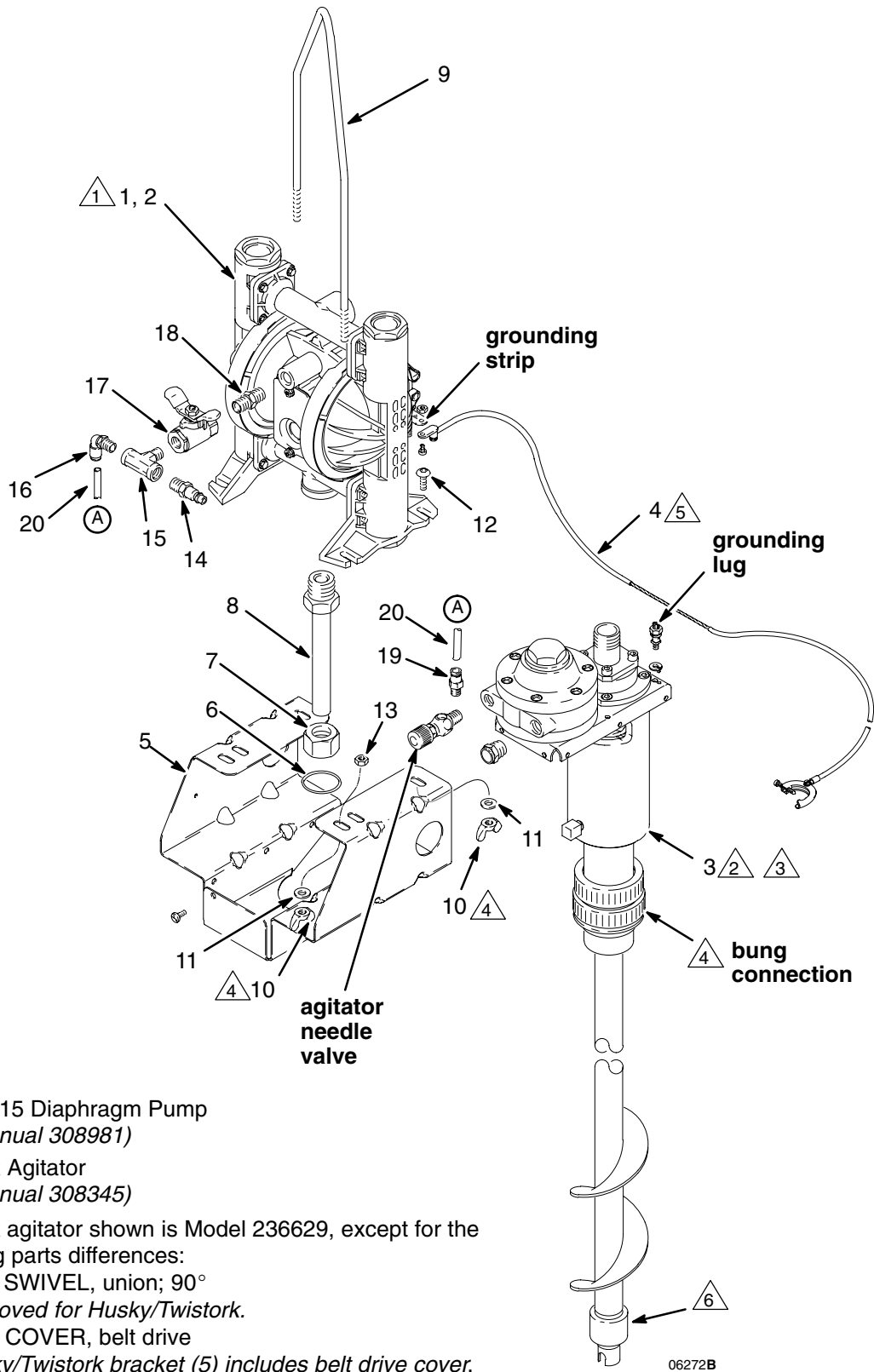

- ① Husky 515 Diaphragm Pump
(see manual 308981)
- ② Twistork Agitator
(see manual 308345)
- ③ Twistork agitator shown is Model 236629, except for the following parts differences:
112572, SWIVEL, union; 90°
Removed for Husky/Twistork.
189648, COVER, belt drive
Husky/Twistork bracket (5) includes belt drive cover.

- ④ Tighten firmly by hand, and check periodically for tightness.
- ⑤ Remove 0.5 in. of insulation approximately 15 in. from end of wire for grounding lug connection.
- ⑥ Husky/Twistork Model 238859 has the optional Rulon® Bearing Nut 189660.

Technical Data

Maximum air input pressure	100 psi (7 bar)
Maximum fluid output pressure	100 psi (7 bar)
Maximum siphon flow rate	
with 100 cps material	12 gpm (45.4 lpm)
with 1000 cps material	1.2 gpm (4.54 lpm)
Air inlet	Quick-coupler, nipple (pin)
Fluid outlet size	3/4 npt(f)
Maximum recommended agitator speed	800 rpm
Agitator air consumption	
at 400 rpm	2.5 scfm (0.07 m ³ /min)
at 800 rpm	5.7 scfm (0.16 m ³ /min)
Pump air consumption at 12 gpm (45.4 lpm)	approximately 12 scfm (0.34 m ³ /min)
Maximum operating temperature	150° F (66° C)
Weight	32 lb (14.5 kg)
Maximum noise level*	85 dB(A)

* Tested to CAGI-PNEUROP-1969

Rulon® is a registered trademark of Dixon, a division of Furon.

Dimensional Drawing

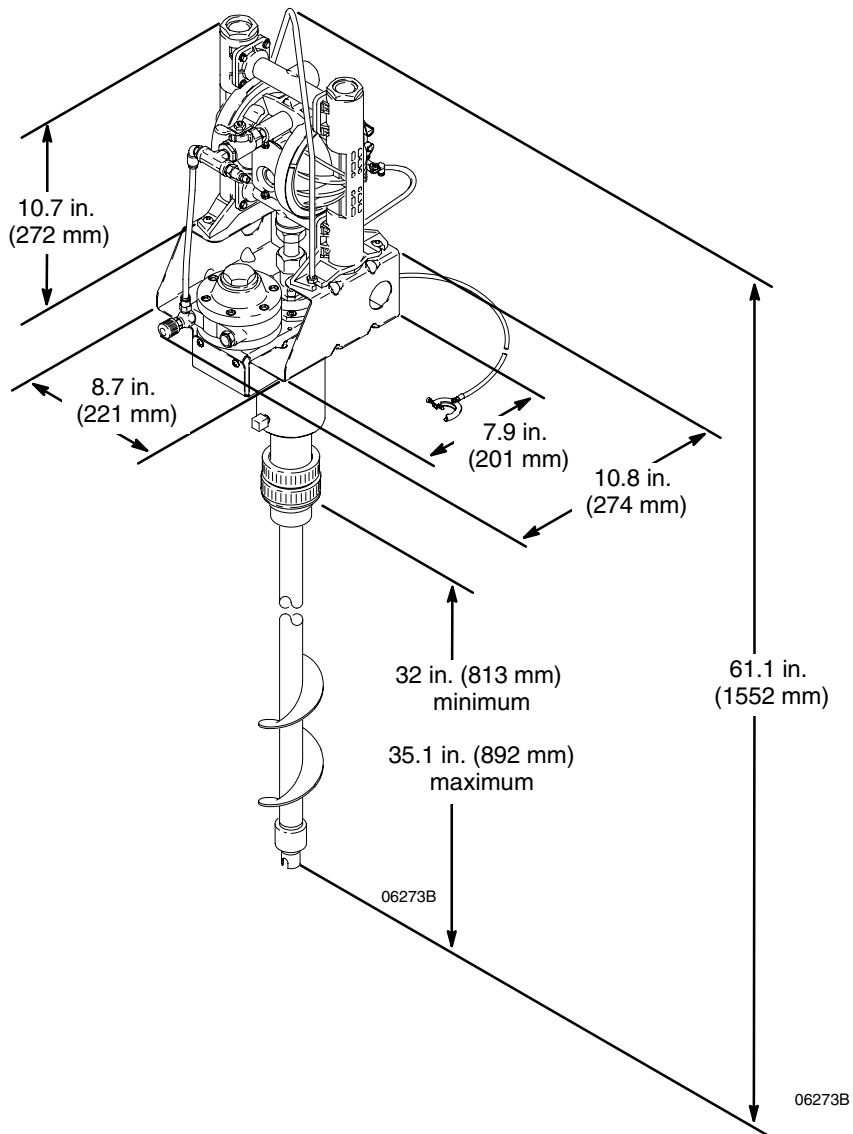

Graco Standard Warranty

Graco warrants all equipment manufactured by Graco and bearing its name to be free from defects in material and workmanship on the date of sale to the original purchaser for use. With the exception of any special, extended, or limited warranty published by Graco, Graco will, for a period of twelve months from the date of sale, repair or replace any part of the equipment determined by Graco to be defective. This warranty applies only when the equipment is installed, operated and maintained in accordance with Graco's written recommendations.

This warranty does not cover, and Graco shall not be liable for general wear and tear, or any malfunction, damage or wear caused by faulty installation, misapplication, abrasion, corrosion, inadequate or improper maintenance, negligence, accident, tampering, or substitution of non-Graco component parts. Nor shall Graco be liable for malfunction, damage or wear caused by the incompatibility of Graco equipment with structures, accessories, equipment or materials not supplied by Graco, or the improper design, manufacture, installation, operation or maintenance of structures, accessories, equipment or materials not supplied by Graco.

This warranty is conditioned upon the prepaid return of the equipment claimed to be defective to an authorized Graco distributor for verification of the claimed defect. If the claimed defect is verified, Graco will repair or replace free of charge any defective parts. The equipment will be returned to the original purchaser transportation prepaid. If inspection of the equipment does not disclose any defect in material or workmanship, repairs will be made at a reasonable charge, which charges may include the costs of parts, labor, and transportation.

THIS WARRANTY IS EXCLUSIVE, AND IS IN LIEU OF ANY OTHER WARRANTIES, EXPRESS OR IMPLIED, INCLUDING BUT NOT LIMITED TO WARRANTY OF MERCHANTABILITY OR WARRANTY OF FITNESS FOR A PARTICULAR PURPOSE.

Graco's sole obligation and buyer's sole remedy for any breach of warranty shall be as set forth above. The buyer agrees that no other remedy (including, but not limited to, incidental or consequential damages for lost profits, lost sales, injury to person or property, or any other incidental or consequential loss) shall be available. Any action for breach of warranty must be brought within two (2) years of the date of sale.

Graco makes no warranty, and disclaims all implied warranties of merchantability and fitness for a particular purpose in connection with accessories, equipment, materials or components sold but not manufactured by Graco. These items sold, but not manufactured by Graco (such as electric motors, switches, hose, etc.), are subject to the warranty, if any, of their manufacturer. Graco will provide purchaser with reasonable assistance in making any claim for breach of these warranties.

In no event will Graco be liable for indirect, incidental, special or consequential damages resulting from Graco supplying equipment hereunder, or the furnishing, performance, or use of any products or other goods sold hereto, whether due to a breach of contract, breach of warranty, the negligence of Graco, or otherwise.

FOR GRACO CANADA CUSTOMERS

The parties acknowledge that they have required that the present document, as well as all documents, notices and legal proceedings entered into, given or instituted pursuant hereto or relating directly or indirectly hereto, be drawn up in English. Les parties reconnaissent avoir convenu que la rédaction du présente document sera en Anglais, ainsi que tous documents, avis et procédures judiciaires exécutés, donnés ou intentés à la suite de ou en rapport, directement ou indirectement, avec les procédures concernées.

Graco Information

For the latest information about Graco products, visit www.graco.com.

TO PLACE AN ORDER, contact your Graco distributor or call to identify the distributor closest to you:

Phone: 612-623-6921 or **Toll Free:** 1-800-328-0211 **Fax:** 612-378-3505

All written and visual data contained in this document reflect the latest product information available at the time of publication.

Graco reserves the right to make changes at any time without notice.

Original instructions. This manual contains English. MM 308656

Graco Headquarters: Minneapolis

International Offices: Belgium, China, Japan, Korea

GRACO INC. P.O. BOX 1441 MINNEAPOLIS, MN 55440-1441

Copyright 1996, Graco Inc. is registered to ISO 9001

www.graco.com

Revised 02/2010