



# Symbols

## Warning Symbol



This symbol alerts you to the possibility of serious injury or death if you do not follow the instructions.

## Caution Symbol



This symbol alerts you to the possibility of damage to or destruction of equipment if you do not follow the instructions.

## WARNING



### EQUIPMENT MISUSE HAZARD

Equipment misuse can cause the equipment to rupture or malfunction and result in serious injury.

- This equipment is for professional use only.
- Read all instruction manuals, tags, and labels before operating the equipment.
- Use the equipment only for its intended purpose. If you are not sure, call your Graco distributor.
- Do not alter or modify this equipment.
- Check equipment daily. Repair or replace worn or damaged parts immediately.
- Do not exceed the maximum working pressure of the lowest rated component in your system. This equipment has a **100 psi (0.7 MPa, 7 bar) maximum working pressure**.
- Use fluids and solvents which are compatible with the equipment wetted parts. Refer to the **Technical Data** section of all equipment manuals. Read the fluid and solvent manufacturer's warnings.
- Always wear protective eyewear, gloves, clothing, and respirator as recommended by the fluid and solvent manufacturer.
- Comply with all applicable local, state, and national fire, electrical, and safety regulations.

# WARNING



## FIRE AND EXPLOSION HAZARD

Improper grounding, poor ventilation, open flames, or sparks can cause a hazardous condition and result in a fire or explosion and serious injury.

- Ground the equipment and the object being sprayed. Refer to **Grounding** on page 4.
- If there is any static sparking or you feel an electric shock while using this equipment, **stop spraying immediately**. Do not use the equipment until you identify and correct the problem.
- Do not use 1,1,1-trichloroethane, methylene chloride, other halogenated hydrocarbon solvents, or fluids containing such solvents in aluminum pumps. Such use could result in a serious chemical reaction, with the possibility of explosion.
- Do not use kerosene or other flammable solvents or combustible gases to flush the unit.
- Provide fresh air ventilation to avoid the buildup of flammable fumes from solvents or the fluid being sprayed.
- Keep the spray area free of debris, including solvent, rags, and gasoline.
- Before operating this equipment, electrically disconnect all equipment in the spray area.
- Before operating this equipment, extinguish all open flames or pilot lights in the spray area.
- Do not smoke in the spray area.
- Do not turn on or off any light switch in the spray area while spraying or while there are any fumes in the air.
- Do not operate a gasoline engine in the spray area.
- Keep a fire extinguisher in the work area.



## MOVING PARTS HAZARD

Moving parts, such as the rotating blades of the agitator, can pinch or amputate your fingers or other body parts and can cause splashing in the eyes or on the skin.

- Keep clear of all moving parts when starting or operating the agitator.
- Always shut off the agitator and disconnect the air line before adjusting the angle of the agitator, removing the agitator from the drum, or checking or repairing any part of the agitator.



## HAZARDOUS VAPORS

Hazardous fluids or toxic fumes can cause serious injury or death if splashed in the eyes or on the skin, swallowed, or inhaled. When flushing the air motor, keep your face away from the exhaust port.

# Installation

## ⚠ WARNING



### FIRE AND EXPLOSION HAZARD

Always maintain a minimum of 1 in. clearance between rotating agitator parts and container to prevent sparks from contact.

### Typical Installation

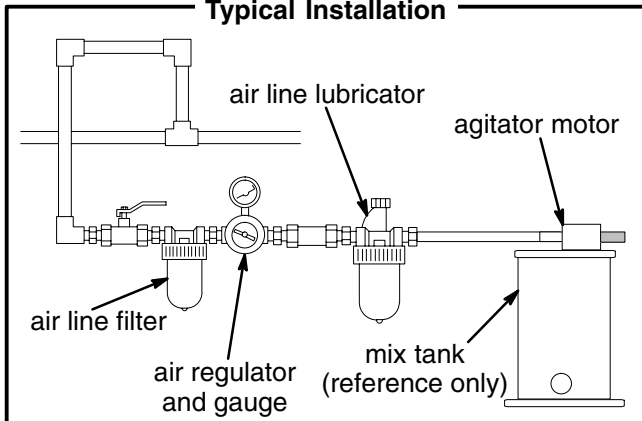

**NOTE:** Reference numbers and letters in parentheses refer to the numbers and letters in the Figures and the Parts Drawings.

## Grounding

Proper grounding is an essential part of maintaining a safe system.

To reduce the risk of static sparking, all electrically conductive objects or devices **must** be properly grounded. Check your local electrical code for detailed grounding instructions for your area and type of equipment.

**To ground the agitator,** connect one end of the ground wire (A) to the ground connector (B) on agitator mounting bracket. See Fig. 1. Connect the other end of the ground wire to a true earth ground.

For a ground wire and clamp, order Part No. 237569.

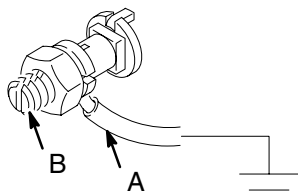

Fig. 1

## Pressure Relief Procedure

## ⚠ WARNING

To reduce the risk of serious bodily injury, including splashing in the eyes or on the skin, or injury from moving parts, which can result if the tank pressure is not fully relieved, *always* follow this procedure before opening the pressure tank cover or fill port.

1. Shut off the air supply to the tank by closing the air inlet valve (A). Refer to Fig. 2.
2. Open the drain cock fitting (B) by turning it counterclockwise.
3. Wait until there is no air escaping through the fitting before removing the cover or opening the fill port.
4. Leave the drain cock fitting open until you have reinstalled the cover or filler cap.





# Installation

- Align the agitator paddle (12) on the agitator shaft (14) as instructed for your model, as follows:

**Models 236662 and 236663 (10 & 15 Gallon)**

Align the top of the paddle hub (G) with the mark (H) on the agitator shaft (14).

**Model 236661 (5 Gallon)**

*If a 5 gallon pail is to be placed inside the pressure tank (5 gallon tank only), align the top of the paddle hub (G) with the upper mark (J) on the agitator shaft (14). If a pail will not be placed inside the tank, align top of hub (G) with the lower mark (H) on the agitator shaft (14).*

After the paddle (12) is properly aligned, apply low strength sealant to the two setscrews (13) and firmly secure the paddle with the setscrews.

- See Fig. 5. Remove plug from air inlet manifold (N). Remove the elbow (37) from the end of the air hose (21) and attach to the pressure tank's air inlet manifold (N).
- Connect the swivel end of the air hose (21) to the elbow (37).
- See Fig. 5. Remove the gear reducer's oil level plug (L) from the street elbow and check the oil level in the reducer housing. The oil should never be higher than the oil level plug. If necessary, drain or add oil until the proper oil level is attained. Screw the oil level plug back onto the street elbow.

**NOTE:** Special high temperature synthetic gear oil is required for the gear reducer. **Use only Graco oil, part number 204559.**

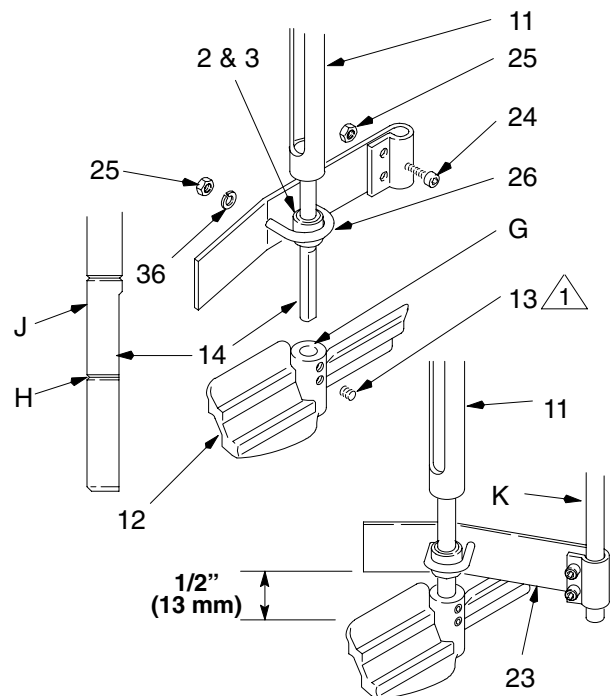

 Apply low strength (cyanoacrylate) thread sealant.

**Fig. 4**

02264

# Operation

## ⚠ WARNING

To reduce the risk of serious bodily injury, which can result if the tank pressure is not fully relieved, *always* follow the **Pressure Relief Procedure** on page 6 before opening the tank cover or fill port.

1. Fill the pressure tank as explained in the Pressure Tank Instruction Manual 308369.
2. Screw on the filler cap (F) (see Fig. 3), or if the tank cover was removed, place the agitator and cover on the pressure tank and secure the cover with the c-clamp handles (M). See Fig. 5.

## ⚠ WARNING

Over-pressurizing the tank or accessories could cause a part to rupture. To reduce the risk of serious injury, including fluid injection and splashing in the eyes or on the skin, or property damage, *never* exceed the maximum air and fluid working pressure of the lowest rated component in your system.

3. Close the tank air regulator(s) by turning the knob(s) counterclockwise. Turn on the air supply.
4. To start the agitator, slowly open the needle valve (20). Adjust the speed of the agitator, with the needle valve, to about 40 to 60 rpm.

## ⚠ CAUTION

**Do not** operate the agitator at a high speed for a long period of time. Excessive agitator speed can cause foaming of fluid (making fluid unusable), or vibration and increased wear on parts. Always agitate the fluid only enough to maintain even mixing.

5. To stop the agitator, close the needle valve (20).

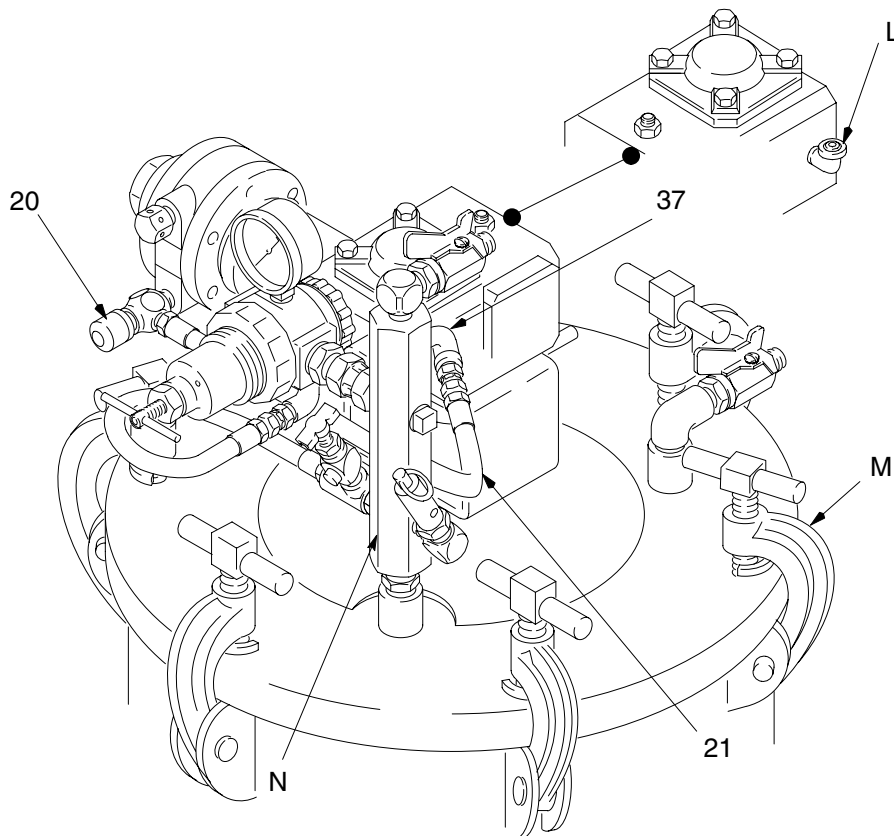

Heavy-Duty Agitator

Fig. 5

03283A

# Service

## WARNING

To reduce the risk of serious bodily injury, including cuts, amputation of fingers, and splashing in the eyes or on the skin, *always* follow the **Pressure Relief Procedure** on page 6, shut off the agitator, and disconnect the air line before checking or repairing the agitator.

### Lubricating the Heavy-Duty Agitator

## CAUTION

Not lubricating the air motor will cause air motor failure.

**Air Motor:** Install an air line lubricator for automatic air motor lubrication. Set the lubricator feed rate at 1 drop of oil per minute for high speed or continuous duty usage. Do not overfeed oil or exhaust air may become contaminated. *To order a 3/8 in. npt air line lubricator, order Part No. 214847.*

If an air line lubricator is not installed, the air motor must be manually lubricated every 8 hours. Lubricate the agitator air motor by placing 10–20 drops of SAE #10 light oil in the motor's air inlet. Run the agitator for about 30 seconds.

**Gear Reducer:** After the first 100 hours or two weeks of operation, remove the oil plug (T) and the oil level plug (L), drain the oil, and thoroughly flush the housing with light flushing oil. See Fig. 6.

Refill with Graco oil (part number 204559) to the proper level.

Afterward, change the oil every six months or 2500 hours of operation (whichever occurs first) under normal operating conditions. More frequent oil changes are needed under severe operating conditions or in atmospheres containing excessive moisture or abrasives. Contact your Graco distributor.

### Flushing the Air Motor

## WARNING



### FIRE AND EXPLOSION HAZARD

Do not use kerosene or other flammable solvents to flush the air motor. Flushing with flammable solvents could cause fire or explosion and result in serious injury or property damage.

## WARNING

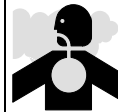

### HAZARDOUS VAPORS

Hazardous fluids or toxic fumes can cause serious injury or death if splashed in the eyes or on the skin, swallowed, or inhaled. When flushing the air motor:

- Keep your face away from the exhaust port.
- Wear the appropriate protective clothing, gloves, eyewear, and respirator.

If the motor is sluggish or inefficient, flush it with non-flammable solvent in a well ventilated area.

The recommended solvent for air motors and lubricated pumps is Gast® Flushing Solvent (Part No. AH255 or AH255A) or Inhibisol® Safety Solvent.

1. Disconnect the air line and muffler.
2. Add several teaspoons of solvent or spray the solvent directly into the motor.
3. Rotate the shaft by hand in both directions for a few minutes.
4. Reconnect the air line, and slowly increase the air pressure until there is no trace of solvent in the exhaust air.
5. Re-lubricate the motor with a squirt of light-weight oil in the chamber.

# Service

- If the unit requires more than installation of a service kit, it is usually quickest and easiest to send the unit to the Graco distributor for repair or replacement.
- If the vanes need replacing, or if foreign material is present in the motor chamber, an experienced mechanic may remove the end plate opposite the drive shaft end. *Do not pry with a screwdriver.* It will dent the surface of the plate and body, causing leaks. Use a puller tool, which will remove the end plate while maintaining the position of the shaft.
- New vanes should have the edges with cut corners (or the notched edges, if the vanes are reversible) pointing toward the bottom of the vane slot.

## Cleaning the Shaft

Each week, clean any dried fluid from around the bearing (38) area of the shaft (14).

## Replacing the Heavy-Duty Air Motor

(See Fig. 6)

### Removing the Heavy-Duty Air Motor

1. Disconnect the air hose (21).
2. Loosen the two setscrews (32) on the collar (2) and remove the air motor (1).

### Installing the Heavy-Duty Air Motor

1. Place one-half of the coupling (3a) on the air motor shaft (S), flush with the end of the shaft. Tighten the coupling setscrew against the flat on the shaft.
2. Install the load cushion (P) on the gear reducer coupling half. Slide the clamp (2) onto the collar (4).
3. Align the two coupling halves (3a), and push the air motor hub into the collar (4) until it bottoms out, then back it out 0.015 in. (0.38 mm). Make sure the air motor inlet and outlet face up.
4. Apply Loctite® No. 222 to the two clamp setscrews (32). Align the setscrews to one side of the slots on the collar (4), and tighten them.
5. Apply pipe thread sealant to the inlet (20) and outlet (22) fittings, and install them in the air motor.

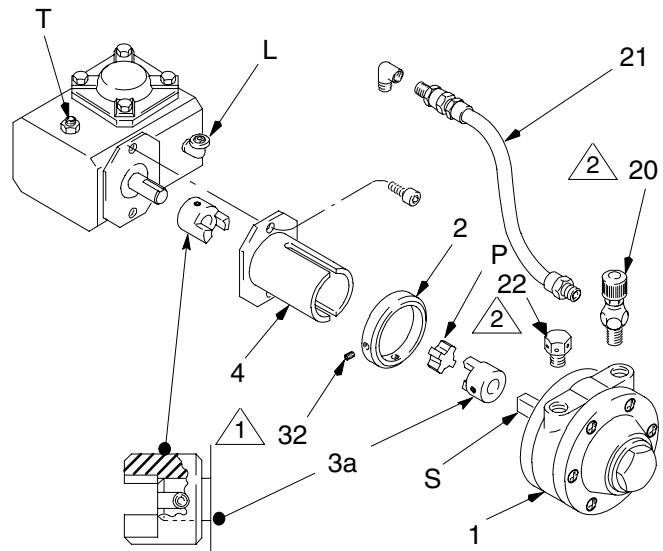

1 Apply Loctite No. 222.

2 Apply low-strength thread sealant.

Fig. 6

## Replacing the Heavy-Duty Gear Reducer

(See Fig. 7)

1. Do not attempt to repair the gear reducer (5) yourself. Contact your Graco distributor.
2. When replacing the gear reducer, turn it upside down and remove the cap screws (33) and washers (40) from the bottom of the old gear reducer. Remove the top coupling half (19a) from the old gear reducer, and install the coupling half on the new gear reducer. Wipe the screw holes clean with a rag.
3. Apply Loctite No. 271, or equivalent, to the four cap screws (33). Install them with the washers (40) through the bracket (6) and into the gear reducer. Make sure the three hole pattern on the bottom of the bracket (6) is orientated in relation to the gear reducer (5) as shown in Fig. 7. **Run the agitator to let the bracket (6) center itself.** Torque the screws to 160 in-lb (18 N•m). Leave the gear reducer upside down for 30 minutes to allow the Loctite to cure. Set the coupling as instructed under **Setting the Agitator Shaft Coupling**, on page 11.

## CAUTION

Do not use the four screws supplied with the new gear reducer to secure it; those screws will not properly secure the gear reducer. Use the cap screws and washers (33 and 40) removed from the old gear reducer. Be careful not to spill any oil from the gear reducer.

# Service

## Servicing the Agitator Shaft and Couplings (See Fig. 7)

### Setting the Agitator Shaft Coupling

1. With the agitator shaft (14) pushed up against the washer (15a), secure the lower portion of the coupling half (19b) to the shaft by tightening the coupling setscrew against the flat on the shaft. Leave about a 0.015 in. gap between the coupling half and washer (15b).
2. Secure the upper coupling half (19a) to the gear reducer shaft by tightening the coupling setscrew into the keyway. Leave about a 0.015 in. gap between each of the coupling halves (19a, 19b) and the load cushion (R).

### Replacing the Agitator Shaft

1. Remove the agitator paddle. Remove the setscrew from the lower coupling (19b). Pull out the agitator shaft (14) and install the new shaft. Replace the agitator paddle.
2. With the agitator shaft (14) pushed up against the washer (15a), secure the lower portion of the coupling half (19b) to the shaft by tightening the coupling setscrew against the flat on the shaft. Leave about a 0.015 in. gap between the coupling half and washer (15b).

### Replacing the Coupling

1. Remove the three cap screws (18), washers (7) and spacers (8) from the mounting bracket (6). Lift the air motor and gearbox off the tank cover. Remove the two coupling halves (19a, 19b) from the shaft ends.
2. Install the new coupling halves on the shaft ends. Replace the air motor/bracket assembly and the three cap screws (18), washers (7) and spacers (8) to fasten the mounting bracket.

### Replacing the Shaft Seals

1. Remove the three cap screws (18), washers (7), and spacers (8) from mounting bracket (6), and move the air motor assembly.
2. With air motor assembly removed, remove the setscrew from the lower coupling half (19b). Pull out the agitator shaft (14).
3. Remove the hex nut (16) and remove the shaft housing (9). Remove the seals (9a, 9b) from the shaft housing, and install the new seals.
4. Reinstall the shaft housing and shaft. Use installation steps listed in **Setting the Agitator Shaft Coupling**.

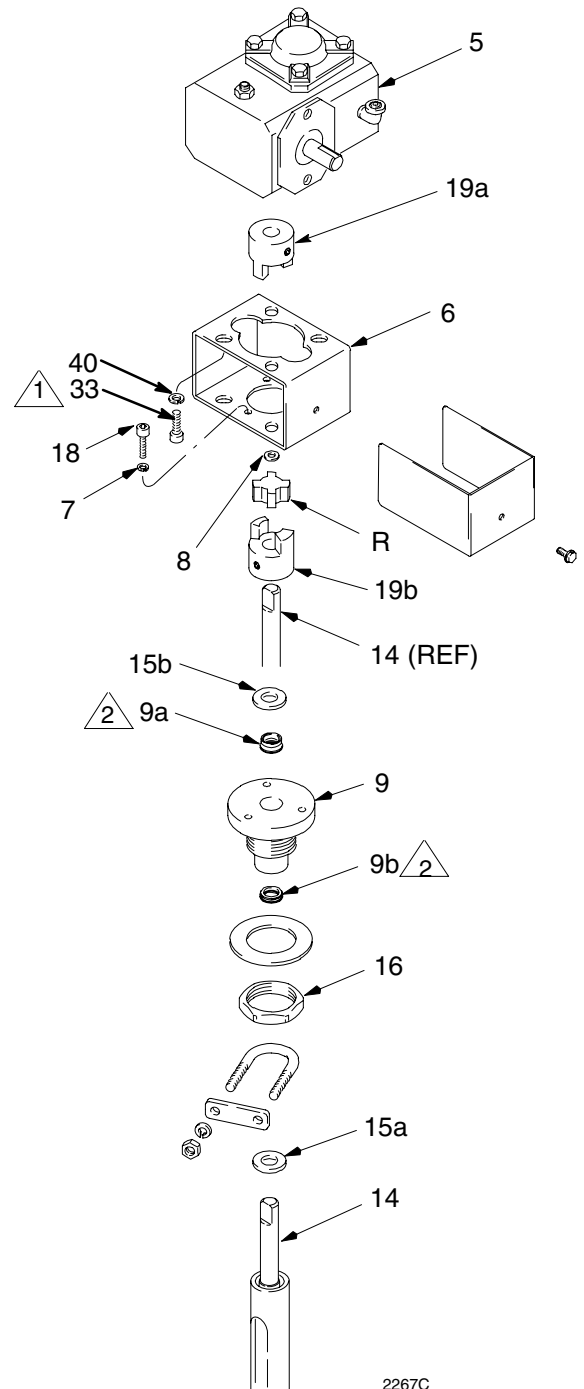

1 Apply Loctite No. 271.  
Torque to 160 in-lbs (18 N-m)

2 Install seals with open spring-loaded  
side toward tank

Fig. 7

# Parts Drawing

**Stainless Steel, Heavy-Duty Agitators**  
**Model No. 236661, 5-gallon size**  
**Model No. 236662, 10-gallon size**  
**Model No. 236663, 15-gallon size**

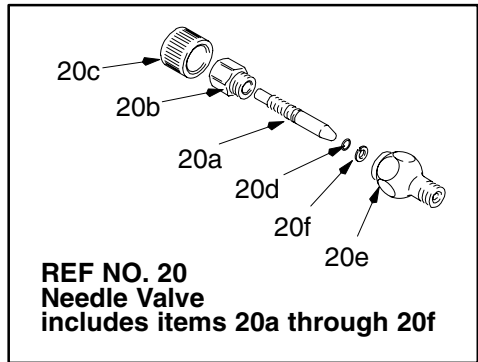
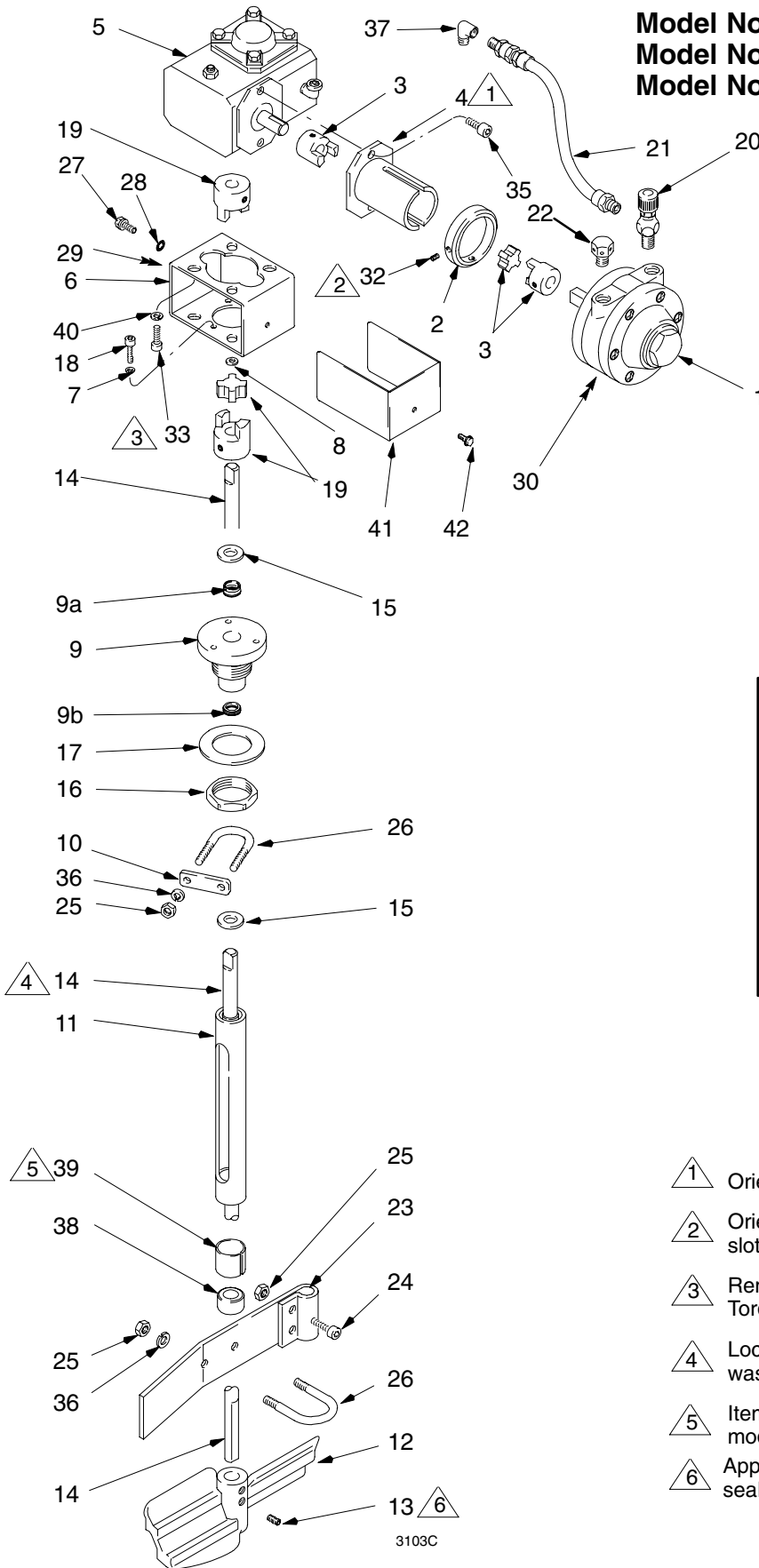

- 1 Orient collar (4) with slots facing up and down.
- 2 Orient screws (32) on collar (2) to either side of slots on mounting collar (4).
- 3 Remove original bolts, and replace with (33). Torque to 160 in-lbs (18 N-m).
- 4 Locate the bottom shoulder of shaft (14) against washer (15) when assembling coupler (19).
- 5 Items (38) and (39) are not used on the 5-gallon model. Attach item (26) to (11) for this model.
- 6 Apply low-strength (cyanoacrylate) thread sealant.

# Parts List

## Stainless Steel, Heavy-Duty Agitators

Model No. 236661, 5-gallon size

Model No. 236662, 10-gallon size

Model No. 236663, 15-gallon size

Ref No.	Part No.	Description	Qty.	Ref No.	Part No.	Description	Qty.
1	162425	MOTOR, air	1	20	206264	VALVE, needle;	
2	181849	COLLAR	1			Includes items 20a to 20f	1
3	100828	COUPLING, flexible	1	20a	166529	· NEEDLE, valve	1
4	220416	COLLAR, mounting;		20b	166532	· NUT, packing	1
		Includes items 4a & 4b	1	20c	164698	· KNOB, packing	1
4a	181848	SLEEVE, mounting, air motor	1	20d	157628	· O-RING; buna-N	1
4b	170751	PLATE, mounting	1	20e	165722	· BODY, valve	1
5	181794	REDUCER, gear	1	20f	166531	· WASHER, nylon	1
6	181749	BRACKET, mounting	1	21	160023	HOSE, coupled; 400 psi	
7	100020	WASHER, lock	3			(2.8 MPa, 28 bar)	
8	108462	SPACER	3			maximum working pressure	1
9	236092	HOUSING, shaft;		22	156969	MUFFLER, exhaust	1
		Includes replaceable items 9a & 9b	1	23	171989	BAFFLE, agitator, sst	1
9a	103553	· SEAL, shaft	1	24	112222	SCREW, cap, socket head;	
9b	104431	· SEAL, shaft	1			1/4-20 x 1 in., (25 mm) sst	2
10	112533	CLAMP, plate, sst	1	25	112223	NUT, hex, regular; 1/4-20, (19 mm)	
11	210576	SUPPORT, shaft;				sst	6
		Includes replaceable item 38	1	26	110278	U-BOLT, clamp; sst	2
12*	236098	PADDLE, agitator; plastic	1	27	111593	SCREW, grounding	1
13	112230	SCREW, set, sch, 1/4-20 x 0.5 in.		28	157021	WASHER, lock, internal	1
		(13 mm)	2	29	186620	LABEL, grounding symbol	1
14	188886	SHAFT, agitator, 15 in., 5 gal size		30 ▲	290152	LABEL, warning	1
		(18.9 liters); sst	1	32	101118	SCREW, set, sch; 10-24 x 0.25 in.	
14	188887	SHAFT, agitator, 20.75 in., 10 gal size				(6 mm) long	2
		(37.8 liters); sst	1	33	110298	SCREW, cap, sch; 1/4-20 x .875 in.	
14	188888	SHAFT, agitator, 31 in., 15 gal size				(22 mm) long	4
		(56.7 liters); sst	1	35	116940	SCREW, cap; 5/16-18 x 1/2 in.	
15	104373	WASHER, thrust; 1/2 in. ID x 1 in. OD	2			(13 mm) long	2
16	188784	NUT, jam, hex; 1-1/2 in.-12;		36	104123	WASHER, lock, sst	4
		stainless steel	1	37	112307	ELBOW, street; 90° x 1/8-27 npt(f)	
17	196309	GASKET, LDPE foam	1			1/8-27 npt(m)	1
18	102598	SCREW, cap, socket head;		38	171970	BEARING PTFE; <i>Included with</i>	
		10-32 x 0.5 in. (13 mm)	3			<i>Models 236662 and 236663 only</i>	1
19	108463	COUPLING, flexible	1	39	187324	HOUSING, bearing; <i>Included with</i>	
						<i>Models 236662 and 236663 only;</i>	
						sst	1
				40	170772	WASHER, flat; 0.26 x 0.69 dia;	
						sst	4
				41	194701	GUARD	1
				42	100078	SCREW, #8-32x3/8 in.	1

\* Stainless steel agitator paddle 186517, 304 stainless steel welded construction, replaces plastic agitator paddle 236098.

▲ Extra warning labels are available for free.

# Technical Data

## Heavy-Duty Models 236661, 236662, and 236663

For fluid viscosity above 800 cps (centipoise)

Air motor: air driven, gear reduced,  
1/2 HP (373 W)  
Air pressure: 100 psi (0.7 MPa, 7 bar) maximum  
Gear ratio: reduced 20:1  
shaft rpm is 1/20 of air motor rpm  
Wetted parts: 304 and 316 stainless steel, PTFE,  
Zytel®, and bronze  
Weight : 21.0 lb (9.5 kg)

\* Sound level measurements taken at 1 meter per  
CAGI-PNEUROP, 1971.

Loctite® is a registered trademark of the Loctite  
Corporation

Zytel® is a registered trademark of the DuPont  
Company.

Gast® is a registered trademark of Gast  
Manufacturing.

Inhibiso® is a registered trademark of Penetone Corp.

### \*Sound data:

Sound pressure

At no load at maximum rpm: 83.4 dB(A)

Under load at 50 rpm: 64.0 dB(A)

Sound power

At no load at maximum rpm: 96.6 dB(A)

Under load at 50 rpm: 77.2 dB(A)

## Air Consumption Chart

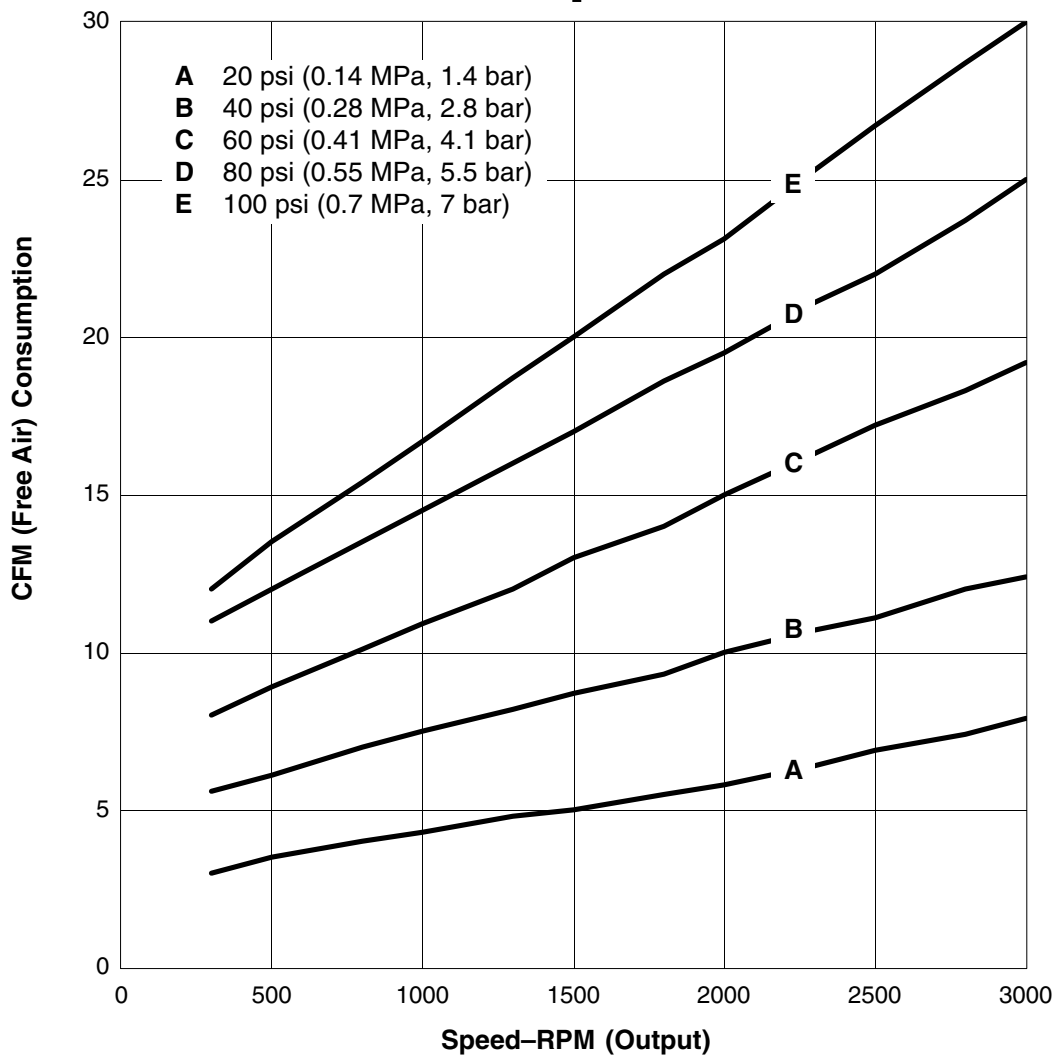



# Graco Standard Warranty

Graco warrants all equipment manufactured by Graco and bearing its name to be free from defects in material and workmanship on the date of sale to the original purchaser for use. With the exception of any special, extended, or limited warranty published by Graco, Graco will, for a period of twelve months from the date of sale, repair or replace any part of the equipment determined by Graco to be defective. This warranty applies only when the equipment is installed, operated and maintained in accordance with Graco's written recommendations.

This warranty does not cover, and Graco shall not be liable for general wear and tear, or any malfunction, damage or wear caused by faulty installation, misapplication, abrasion, corrosion, inadequate or improper maintenance, negligence, accident, tampering, or substitution of non-Graco component parts. Nor shall Graco be liable for malfunction, damage or wear caused by the incompatibility of Graco equipment with structures, accessories, equipment or materials not supplied by Graco, or the improper design, manufacture, installation, operation or maintenance of structures, accessories, equipment or materials not supplied by Graco.

This warranty is conditioned upon the prepaid return of the equipment claimed to be defective to an authorized Graco distributor for verification of the claimed defect. If the claimed defect is verified, Graco will repair or replace free of charge any defective parts. The equipment will be returned to the original purchaser transportation prepaid. If inspection of the equipment does not disclose any defect in material or workmanship, repairs will be made at a reasonable charge, which charges may include the costs of parts, labor, and transportation.

**THIS WARRANTY IS EXCLUSIVE, AND IS IN LIEU OF ANY OTHER WARRANTIES, EXPRESS OR IMPLIED, INCLUDING BUT NOT LIMITED TO WARRANTY OF MERCHANTABILITY OR WARRANTY OF FITNESS FOR A PARTICULAR PURPOSE.**

Graco's sole obligation and buyer's sole remedy for any breach of warranty shall be as set forth above. The buyer agrees that no other remedy (including, but not limited to, incidental or consequential damages for lost profits, lost sales, injury to person or property, or any other incidental or consequential loss) shall be available. Any action for breach of warranty must be brought within two (2) years of the date of sale.

Graco makes no warranty, and disclaims all implied warranties of merchantability and fitness for a particular purpose in connection with accessories, equipment, materials or components sold but not manufactured by Graco. These items sold, but not manufactured by Graco (such as electric motors, switches, hose, etc.), are subject to the warranty, if any, of their manufacturer. Graco will provide purchaser with reasonable assistance in making any claim for breach of these warranties.

In no event will Graco be liable for indirect, incidental, special or consequential damages resulting from Graco supplying equipment hereunder, or the furnishing, performance, or use of any products or other goods sold hereto, whether due to a breach of contract, breach of warranty, the negligence of Graco, or otherwise.

## **FOR GRACO CANADA CUSTOMERS**

The parties acknowledge that they have required that the present document, as well as all documents, notices and legal proceedings entered into, given or instituted pursuant hereto or relating directly or indirectly hereto, be drawn up in English. Les parties reconnaissent avoir convenu que la rédaction du présente document sera en Anglais, ainsi que tous documents, avis et procédures judiciaires exécutés, donnés ou intentés à la suite de ou en rapport, directement ou indirectement, avec les procédures concernées.

## Graco Information

**TO PLACE AN ORDER**, contact your Graco distributor, or call this number to identify the distributor closest to you:

**1-800-328-0211 Toll Free**

**612-623-6921**

**612-378-3505 Fax**

*All written and visual data contained in this document reflects the latest product information available at the time of publication.  
Graco reserves the right to make changes at any time without notice.*

This manual contains English. MM 308371

**Graco Headquarters:** Minneapolis

**International Offices:** Belgium, China, Japan, Korea

**GRACO INC. P.O. BOX 1441 MINNEAPOLIS, MN 55440-1441**

**www.graco.com**

308371 07/1994, Revised 07/2007