

Symbols

Warning Symbol



This symbol alerts you to the possibility of serious injury or death if you do not follow the instructions.

Caution Symbol



This symbol alerts you to the possibility of damage to or destruction of equipment if you do not follow the instructions.

WARNING



INSTRUCTIONS

EQUIPMENT MISUSE HAZARD

Equipment misuse can cause the equipment to rupture or malfunction and result in serious injury.

- This equipment is for professional use only.
- Read all instruction manuals, tags, and labels before operating the equipment.
- Use the equipment only for its intended purpose. If you are not sure, call your Graco distributor.
- Do not alter or modify this equipment.
- Check equipment daily. Repair or replace worn or damaged parts immediately.
- Do not exceed the maximum working pressure of the lowest rated component in your system. This equipment has a **100 psi (7 bar) maximum working pressure**.
- Use fluids and solvents that are compatible with the equipment wetted parts. Refer to the **Technical Data** section of all equipment manuals. Read the fluid and solvent manufacturer's warnings.
- Always wear protective eyewear, gloves, clothing, and respirator as recommended by the fluid and solvent manufacturer.
- Comply with all applicable local, state, and national fire, electrical, and safety regulations.

WARNING



FIRE AND EXPLOSION HAZARD

Improper grounding, poor ventilation, open flames, or sparks can cause a hazardous condition and result in a fire or explosion and serious injury.

- Ground all equipment. Refer to **Grounding** on page 5.
- If there is any static sparking or you feel an electric shock while using this equipment, **shut off the agitator immediately**. Do not use the equipment until you identify and correct the problem.
- Do not use 1,1,1-trichloroethane, methylene chloride, other halogenated hydrocarbon solvents, or fluids containing such solvents in aluminum pumps. Such use could result in a serious chemical reaction, with the possibility of explosion.
- Do not use kerosene or other flammable solvents or combustible gases to flush the unit.
- Provide fresh air ventilation to avoid the buildup of flammable fumes from solvents or the fluid being dispensed.
- Keep the dispensing area free of debris, including solvent, rags, and gasoline.
- Do not smoke in the dispensing area.
- Keep a fire extinguisher in the work area.



MOVING PARTS HAZARD

Moving parts, such as the rotating blades of the agitator, can pinch or amputate your fingers or other body parts and can cause splashing in the eyes or on the skin.

- Keep clear of all moving parts when starting or operating the agitator.
- Always shut off the agitator and disconnect the air line before you remove the agitator from the drum or check or repair any part of the agitator.



HAZARDOUS VAPORS

Hazardous fluids or toxic fumes can cause serious injury or death if splashed in the eyes or on the skin, swallowed, or inhaled. When flushing the air motor, keep your face away from the exhaust port.

Installation

⚠ WARNING



FIRE AND EXPLOSION HAZARD

Always maintain a minimum of 1 in. clearance between rotating agitator parts and container to prevent sparks from contact.

Typical Installation

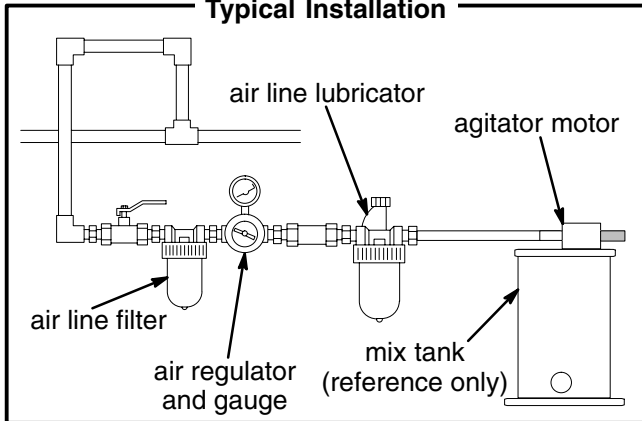

NOTE: Reference numbers and letters in text refer to the Figures and Parts Drawings.

Air Requirements

For continuous use, the 1/2 HP agitator air motor typically requires 2 scfm (0.06 m³/min.) of air at 400 rpm and with 100 psi (7 bar) inlet pressure.

Air Line Accessories

Install an **air line filter** to remove harmful dirt and moisture from the air supply. Order Part No. 106148 for 3/8 npt or 106146 for 1/2 npt.

⚠ CAUTION

Not lubricating the air motor will cause air motor failure.

Downstream from the filter, install an air line lubricator for automatic air motor lubrication. Set the lubricator feed rate at 1 drop of oil per minute for high speed or continuous duty usage. Do not overfeed oil or exhaust air may become contaminated. To manually lubricate the air motor, see **Lubricating the Air Motor** on page 7. To order a 3/8" npt air line lubricator, order Part No. 214847.

Installing the Agitator

1. Install the agitator on the container cover by screwing the helix through the drum bung hole and screwing the agitator housing into the bung hole. Refer to the Dimension Drawing on page 11.

⚠ CAUTION

Keep the agitator tightly mounted to the drum bung to prevent damage to the threads from vibration.

When using a modified drum check that there is no interference between the base of the drum and the shaft of the agitator.

2. Position the air motor so the air line can easily be attached to the needle valve's 1/8 npt inlet, without obstructing any other system components. See Fig. 1.
3. Attach an **air line quick disconnect valve** or ball valve for main air shutoff. Order Part No. 208536, Coupler and 169969 Fitting, Quick Disconnect Air Line Fitting.
4. Attach the air line between the needle valve's 1/8 npt inlet and the 1/8 npt air supply manifold outlet.

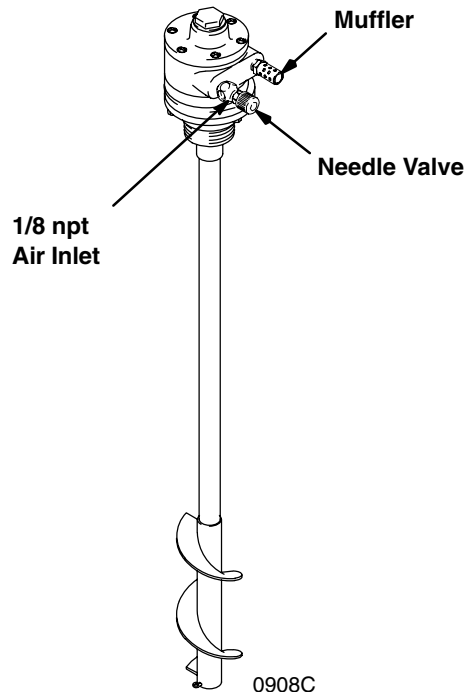

Fig. 1

Installation

Grounding

Proper grounding is an essential part of maintaining a safe system.

To reduce the risk of static sparking, all electrically conductive objects or devices in the spray area **must** be properly grounded. Check your local electrical code for detailed grounding instructions for your area and type of equipment.

To ground the agitator:

Remove the grounding screw (A) and lockwasher (B). See Fig. 2. Secure the ground wire terminal (C) to the agitator with the screw and lockwasher. Connect the other end of the ground wire to a true earth ground. Order Part No. 222011, Ground Wire and Clamp.

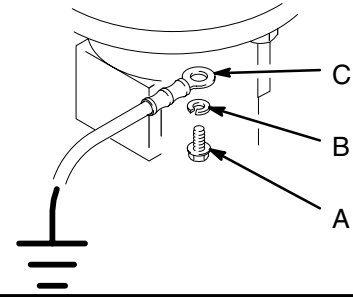

01089

Fig. 2

Operation

WARNING



MOVING PARTS HAZARD

To reduce the risk of serious injury, including cuts, amputation of fingers, and splashing in the eyes or on the skin:

- Always shut off the mixer and disconnect the air line before checking or repairing the mixer.

Operating the Agitator

1. Fill the fluid supply container.
2. Start the agitator.
3. Use the agitator needle valve to regulate the agitator speed. The needle valve has numbered graduations to refer to when setting the agitator speed. Set the agitator at speeds that minimize vibration.

NOTE: If an air shut-off valve is installed in the supply line and used to stop the agitator, the same agitator speed will be set each time the agitator is used. Part numbers for air shut-off valves are listed below:

208390 1/4 npt(m) x 1/4 npt(m)

208391 3/8 npt(m) x 3/8 npt(f)

208392 3/8 npt(f) x 1/4 npt(m)

208393 3/8 npt(m) x 3/8 npt(m)

CAUTION

Do not operate the agitator at a high speed for a long period of time. Excessive agitator speed can cause foaming of fluid (making the fluid unusable), vibration, and increased wear on parts. Always agitate the fluid only enough to maintain even mixing.

4. Operate the agitator continuously while supplying paints or other fluids to the system.
5. To stop the agitator, close the air valve in the air supply line if you have one, or close the agitator needle valve.

NOTE: The agitator rotation may be reversed by switching the muffler and needle valve. Refer to Fig. 1.

Checking Fluid Viscosity

If the agitator is in a closed drum, the agitator must be removed to check the fluid viscosity or the fluid must be siphoned from the 3/4 npt drum port.

Service

WARNING



MOVING PARTS HAZARD

To reduce the risk of serious injury, including cuts, amputation of fingers, and splashing in the eyes or on the skin:

- Always shut off the mixer and disconnect the air line before checking or repairing the mixer.
- Wear eye protection.

WARNING



FIRE AND EXPLOSION HAZARD

To prevent an explosive hazard, where injury and/or property damage can result:

- Do not operate this air motor with combustible gases.
- **Do not use kerosene or other flammable solvents to flush unit.**
- Keep face away from exhaust port. Foreign material exiting the air motor can be hazardous.

Flushing

If the motor is sluggish or inefficient, flush it with non-flammable solvent in a well ventilated area.

The recommended solvent for air motors and lubricated pumps is Gast® Flushing Solvent (Part No. AH255 or AH255A) or Inhibisol® Safety Solvent.

1. Disconnect the air line and muffler.
2. Add several teaspoons of solvent or spray the solvent directly into the motor.
3. Rotate the shaft by hand in both directions for a few minutes.
4. Reconnect the air line and slowly apply pressure until there is no trace of solvent in the exhaust air.
5. Re-lubricate the motor with a squirt of light-weight oil in the chamber.

Gast® is a registered trademark of Gast Manufacturing.

Inhibisol® is a registered trademark of Penetone Corp.

Servicing

- If the unit requires more than installation of a service kit, it is usually quickest and easiest to send the unit to the Graco distributor for repair or replacement.
- If the vanes need replacing or foreign material is present in the motor chamber, an experienced mechanic may remove the end plate opposite the drive shaft end. *Do not pry with a screwdriver.* It will dent the surface of the plate and body, causing leaks. Use a puller tool, which will remove the end plate while maintaining the position of the shaft.
- New vanes should have the edges with cut corners (or the notched edges, if the vanes are reversible) pointing toward the bottom of the vane slot.

NOTE: An Air Motor Repair Kit is available. Order part number 224954.

Aligning the Outlet Housing after Repairing or Replacing the Outlet Housing or Air Motor

CAUTION

Improper installation of the outlet housing could cause the agitator shaft to bind against the outlet housing bearing and damage it.

1. Place the agitator in a vertical position and loosen the three outlet housing screws (17). See Parts Drawing.
2. Apply 25 psi (1.7 bar) minimum air pressure to the air motor. Adjust the needle valve so the agitator is barely turning.
3. While the agitator shaft is turning, torque the three outlet housing screws to 80 to 100 in-lbs (9 to 11.3 N•m).
4. If the agitator shaft still binds, repeat steps 1 to 3 above.

Lubricating the Air Motor

CAUTION

Not lubricating the air motor will cause air motor failure.

If an air line lubricator is not installed, the air motor must be manually lubricated every 8 hours. Lubricate the agitator air motor by placing 10–20 drops of SAE #10 light oil in the motor's air inlet. Run the agitator for about 30 seconds.

Parts

Model 224854 Twistork™ Helix Mixer
Carbon Steel, Includes items 1 to 22

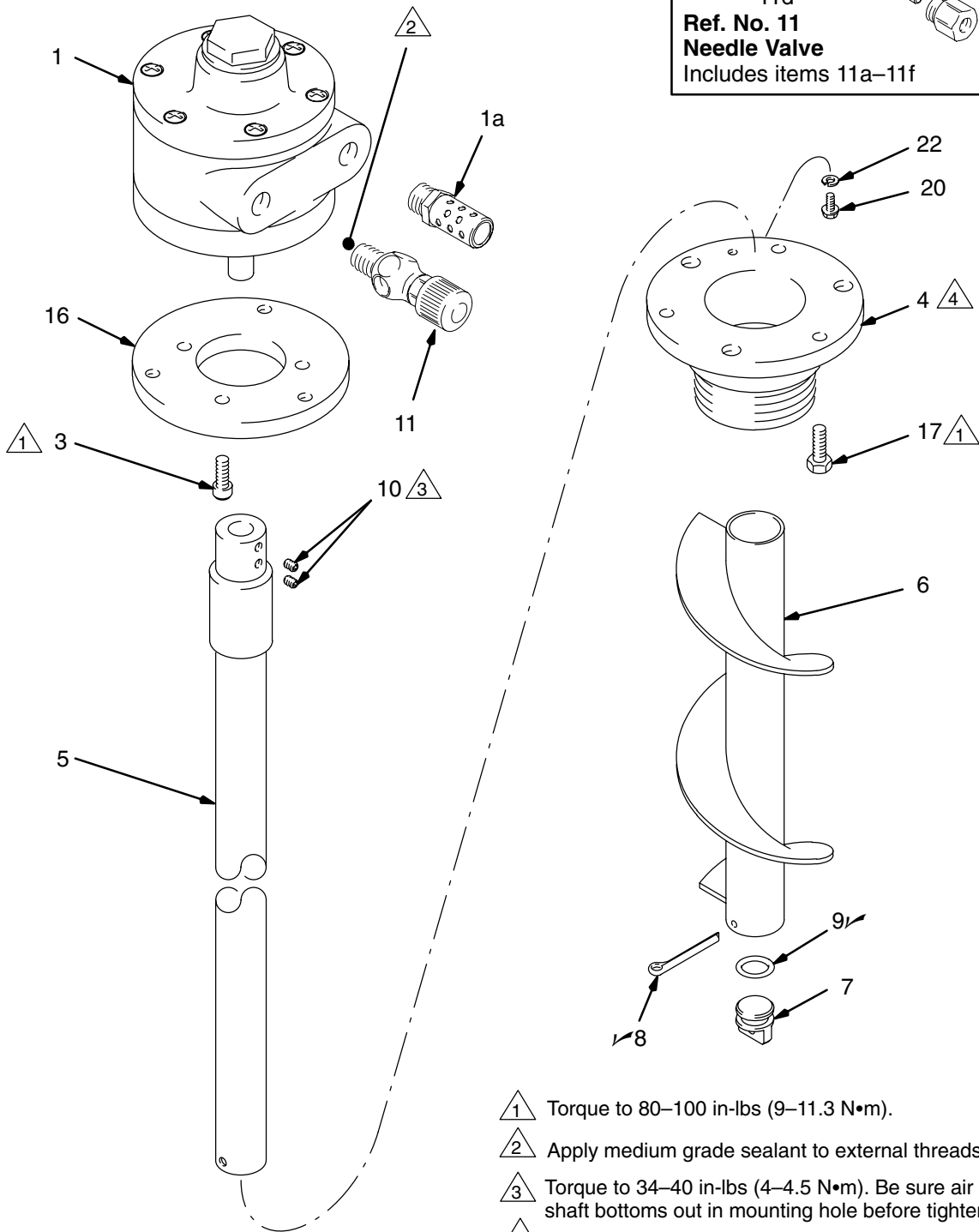
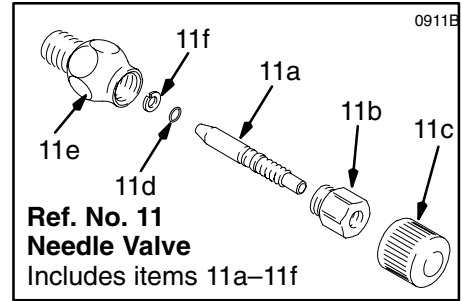

- ① Torque to 80–100 in-lbs (9–11.3 N•m).
- ② Apply medium grade sealant to external threads.
- ③ Torque to 34–40 in-lbs (4–4.5 N•m). Be sure air motor shaft bottoms out in mounting hole before tightening.
- ④ Align as instructed on page 7.

0907B

Parts

Model 224854 Twistork™ Helix Mixer

Carbon Steel, Includes items 1 to 22

Ref. No.	Part No.	Description	Qty.
1*	111310	MOTOR, air; Includes item 1a	1
1a	113779	• MUFFLER, exhaust	1
3	101682	SCREW, cap, sch; 1/4–20 x 0.625	3
4	224876	HOUSING, outlet, carbon steel	1
5	224852	SHAFT, agitator	1
6	224393	HELIX, agitator	1
7	187054	PLUG, fluid tube	1
8✓	101946	PIN, cotter	1
9✓	111312	O-RING, Fluoroelastomer	1
10	112364	SCREW, set, socket; 1/4–20 UNC 3A	2
11	206264	VALVE, needle <i>Includes items 11a to 11f</i>	1
11a	166529	.VALVE, needle	1
11b	166532	.NUT, packing	1
11c	164698	.KNOB, adjusting	1
11d	157628	.O-RING, packing	1
11e	165722	.BODY, valve	1
11f	166531	.WASHER	1
16	187577	PLATE, motor mounting	1
17	102023	SCREW, cap, hex hd; 1/4–20 x 0.75	3
20	111593	SCREW, grounding; hex, No. 8–32	1
22	157021	WASHER, lock	1

* *Repair Kit 224954 used to rebuild air motor 111310, may be purchased separately.*

✓ *Keep these spare parts on hand to reduce down time.*

Parts

Model 235534 Twistork™ Helix Mixer
Stainless Steel, Includes items 1 to 22

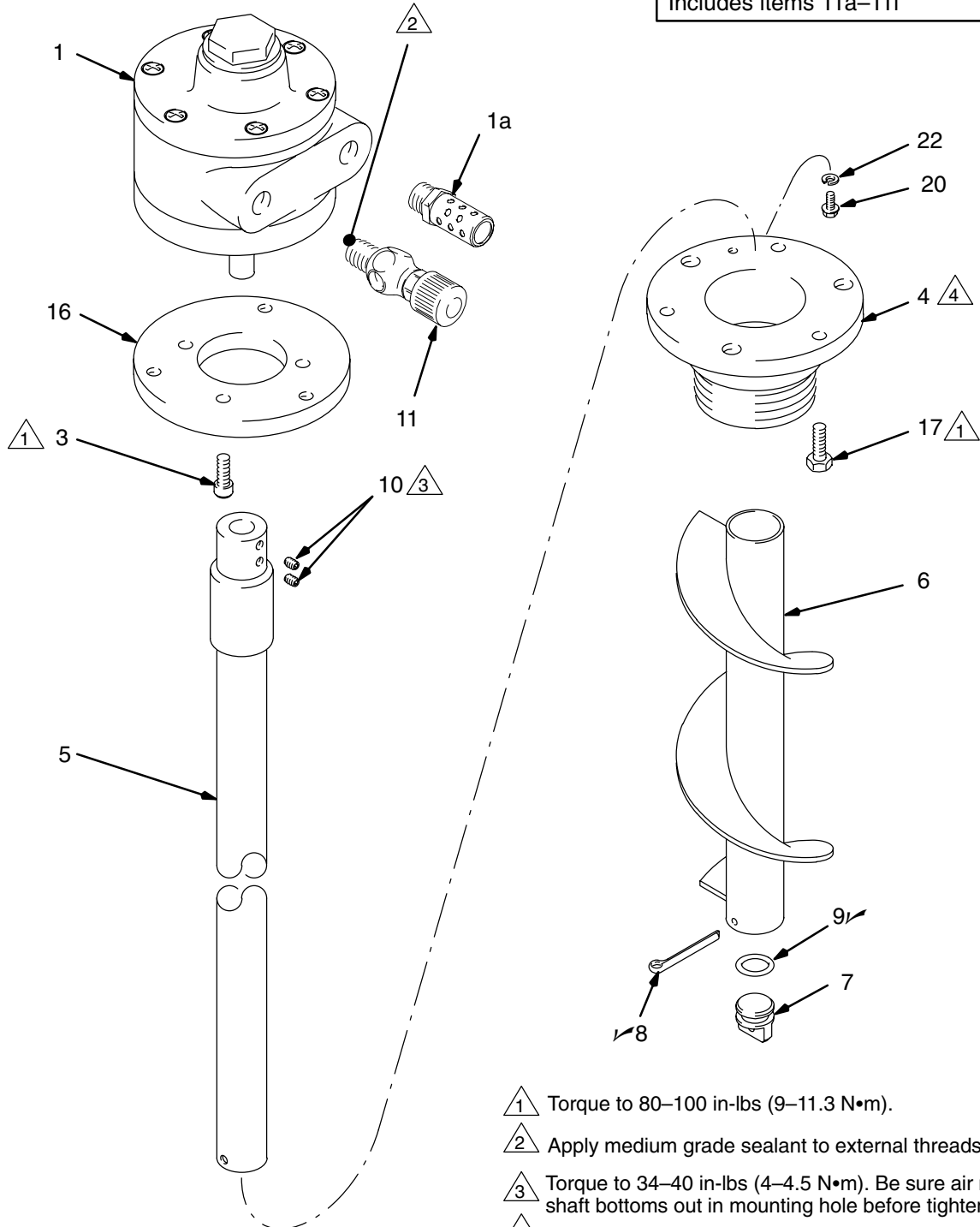
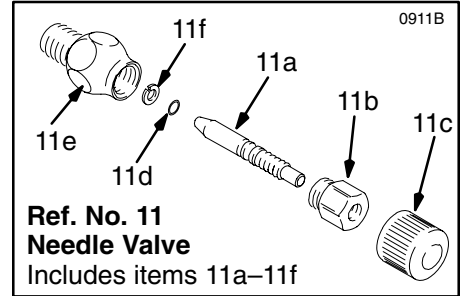

- ① Torque to 80–100 in-lbs (9–11.3 N•m).
- ② Apply medium grade sealant to external threads.
- ③ Torque to 34–40 in-lbs (4–4.5 N•m). Be sure air motor shaft bottoms out in mounting hole before tightening.
- ④ Align as instructed on page 7.

0907B

Parts

Dimensions

Model 235534 Twistork™ Helix Mixer

Stainless Steel, Includes items 1 to 22

Ref. No.	Part No.	Description	Qty.
1*	111310	MOTOR, air; Includes item 1a	1
1a	113779	• MUFFLER, exhaust	1
3	101682	SCREW, cap, sch; 1/4-20 x 0.625	3
4	235535	HOUSING, outlet, stainless steel	1
5	235530	SHAFT, agitator, stainless steel	1
6	224393	HELIX, agitator	1
7	187054	PLUG, fluid tube	1
8✓	101946	PIN, cotter	1
9✓	111312	O-RING, Fluoroelastomer	1
10	112364	SCREW, set, socket; 1/4-20 UNC 3A	2
11	206264	VALVE, needle <i>Includes items 11a to 11f</i>	1
11a	166529	.VALVE, needle	1
11b	166532	.NUT, packing	1
11c	164698	.KNOB, adjusting	1
11d	157628	.O-RING, packing	1
11e	165722	.BODY, valve	1
11f	166531	.WASHER	1
16	187577	PLATE, motor mounting	1
17	102023	SCREW, cap, hex hd; 1/4-20 x 0.75	3
20	111593	SCREW, grounding; hex, No. 8-32	1
22	157021	WASHER, lock	1

* Repair Kit 224954 used to rebuild air motor 111310, may be purchased separately.

✓ Keep these spare parts on hand to reduce down time.

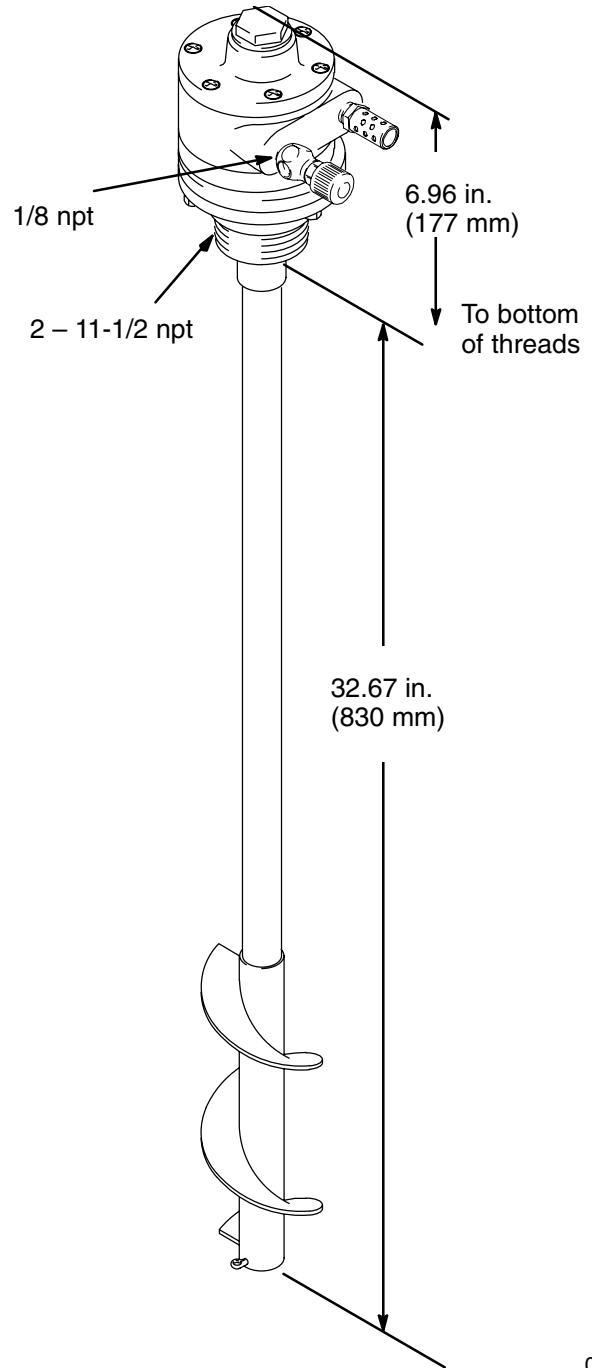

0908C

Technical Data

Maximum Working Pressure 100 psi (7 bar)

Maximum Recommended Agitator Speed 800 rpm

Air Consumption

At 800 rpm with 100 psi (7 bar) air inlet pressure:
5 scfm (0.14 m³/min.)

At 400 rpm with 100 psi (7 bar) air inlet pressure:
2 scfm (0.06 m³/min.)

Weight 17.6 lb (8 kg)

Wetted Parts

Model 224854 . . . Carbon Steel, Fluoroelastomer,
Acetal

Model 235534 304 & 316 Stainless Steel,
Fluoroelastomer, Acetal

External Parts that may come in contact with fluids:

Plate Carbon Steel

Air Motor Aluminum

*Noise Level at 100 psi normal load

at 800 rpm: Pressure 71.3 dB(A)

Power 84.6 dB(A)

*Noise Level at 100 psi at no load

at max rpm: Pressure 84.1 dB(A)

Power 97.4 dB(A)

*Tested to CAGI-PNEUROP-1969

Graco Standard Warranty

Graco warrants all equipment manufactured by Graco and bearing its name to be free from defects in material and workmanship on the date of sale to the original purchaser for use. With the exception of any special, extended, or limited warranty published by Graco, Graco will, for a period of twelve months from the date of sale, repair or replace any part of the equipment determined by Graco to be defective. This warranty applies only when the equipment is installed, operated and maintained in accordance with Graco's written recommendations.

This warranty does not cover, and Graco shall not be liable for general wear and tear, or any malfunction, damage or wear caused by faulty installation, misapplication, abrasion, corrosion, inadequate or improper maintenance, negligence, accident, tampering, or substitution of non-Graco component parts. Nor shall Graco be liable for malfunction, damage or wear caused by the incompatibility of Graco equipment with structures, accessories, equipment or materials not supplied by Graco, or the improper design, manufacture, installation, operation or maintenance of structures, accessories, equipment or materials not supplied by Graco.

This warranty is conditioned upon the prepaid return of the equipment claimed to be defective to an authorized Graco distributor for verification of the claimed defect. If the claimed defect is verified, Graco will repair or replace free of charge any defective parts. The equipment will be returned to the original purchaser transportation prepaid. If inspection of the equipment does not disclose any defect in material or workmanship, repairs will be made at a reasonable charge, which charges may include the costs of parts, labor, and transportation.

THIS WARRANTY IS EXCLUSIVE, AND IS IN LIEU OF ANY OTHER WARRANTIES, EXPRESS OR IMPLIED, INCLUDING BUT NOT LIMITED TO WARRANTY OF MERCHANTABILITY OR WARRANTY OF FITNESS FOR A PARTICULAR PURPOSE.

Graco's sole obligation and buyer's sole remedy for any breach of warranty shall be as set forth above. The buyer agrees that no other remedy (including, but not limited to, incidental or consequential damages for lost profits, lost sales, injury to person or property, or any other incidental or consequential loss) shall be available. Any action for breach of warranty must be brought within two (2) years of the date of sale.

Graco makes no warranty, and disclaims all implied warranties of merchantability and fitness for a particular purpose in connection with accessories, equipment, materials or components sold but not manufactured by Graco. These items sold, but not manufactured by Graco (such as electric motors, switches, hose, etc.), are subject to the warranty, if any, of their manufacturer. Graco will provide purchaser with reasonable assistance in making any claim for breach of these warranties.

In no event will Graco be liable for indirect, incidental, special or consequential damages resulting from Graco supplying equipment hereunder, or the furnishing, performance, or use of any products or other goods sold hereto, whether due to a breach of contract, breach of warranty, the negligence of Graco, or otherwise.

FOR GRACO CANADA CUSTOMERS

The parties acknowledge that they have required that the present document, as well as all documents, notices and legal proceedings entered into, given or instituted pursuant hereto or relating directly or indirectly hereto, be drawn up in English. Les parties reconnaissent avoir convenu que la rédaction du présente document sera en Anglais, ainsi que tous documents, avis et procédures judiciaires exécutés, donnés ou intentés à la suite de ou en rapport, directement ou indirectement, avec les procédures concernées.

Graco Information

TO PLACE AN ORDER, contact your Graco distributor, or call this number to identify the distributor closest to you:

1-800-328-0211 Toll Free

612-623-6921

612-378-3505 Fax

*All written and visual data contained in this document reflects the latest product information available at the time of publication.
Graco reserves the right to make changes at any time without notice.*

This manual contains English. MM 308175

Graco Headquarters: Minneapolis

International Offices: Belgium, China, Japan, Korea

GRACO INC. P.O. BOX 1441 MINNEAPOLIS, MN 55440-1441

www.graco.com

12/1991, Revised 10/2007