



INSTRUCTIONS

This manual contains important warnings and information.
READ AND KEEP FOR REFERENCE.

First choice when quality counts.™

Ultra-Lite™ In-Line Flow Gun Repair Kit

Part No. 240-206

For Part No. 240-199 Ultra-Lite In-Line Flow Gun, with Ball End Needle

Part No. 240-207

For Part No. 240-200 Ultra-Lite In-Line Flow Gun, with Tapered Needle

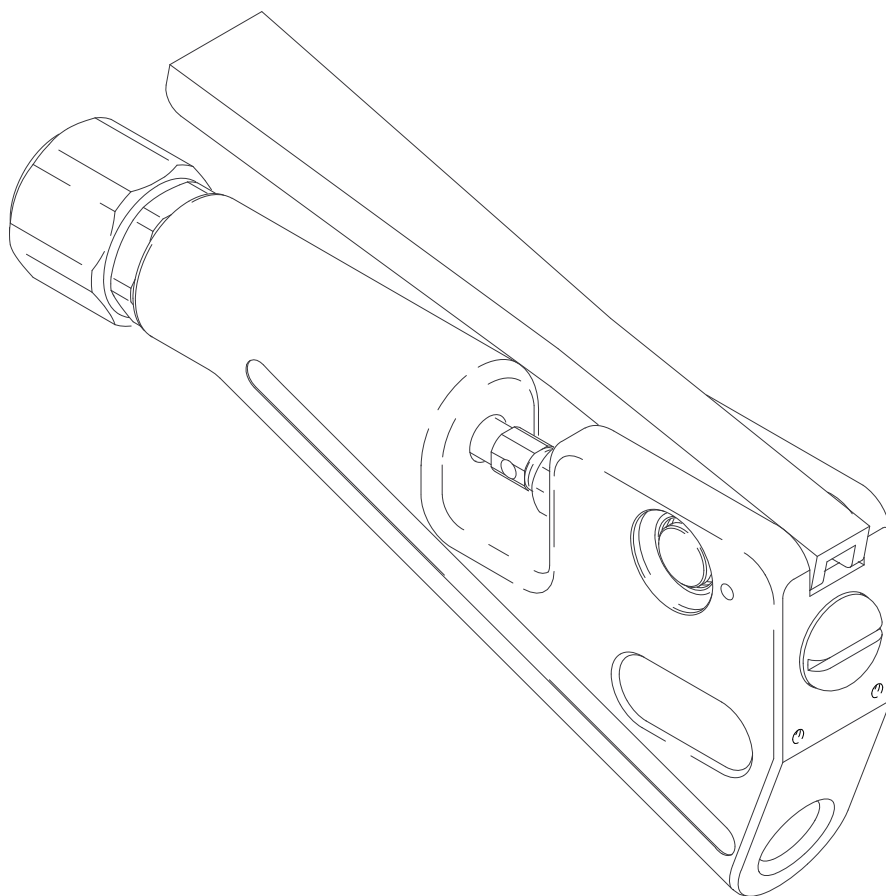

7903A

Installation

Pressure Relief Procedure

⚠ WARNING



INJECTION HAZARD

The system pressure must be manually relieved to prevent the system from starting or dispensing accidentally. Fluid under high pressure can be injected through the skin and cause serious injury. To reduce the risk of an injury from injection, splashing fluid, or moving parts, follow the **Pressure Relief Procedure** whenever you:

- are instructed to relieve the pressure,
- stop dispensing,
- check or service any of the system equipment,
- or install or clean the nozzle.

1. Fully release the gun trigger. Press the red button to lock the trigger safety. See Fig. 1.
2. Shut off the fluid supply pump.
3. Hold a metal part of the gun firmly to the side of a grounded metal pail. Press the silver button to unlock the trigger safety. Trigger the gun to relieve pressure.
4. Open the pump drain valve to help relieve pressure in the pump, hose, and gun. Triggering the gun to relieve pressure may not be sufficient. Have a container ready to catch the drainage.
5. Leave the drain valve open until you are ready to dispense again.
6. Fully release the gun trigger and lock the trigger safety.

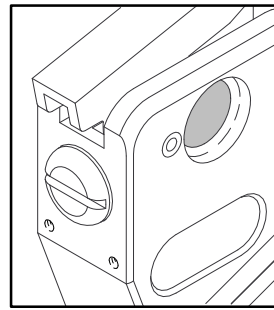

**Trigger Safety
Locked**

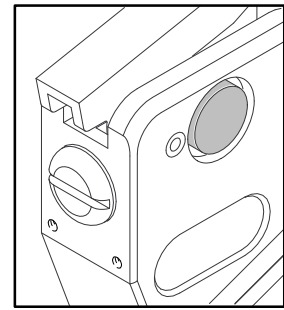

**Trigger Safety
Unlocked**

Fig. 1

Disassembly

1. **Relieve the pressure.**
 2. Disconnect the gun from the hose.
 3. Unscrew the nozzle nut (C) and nozzle (not shown) from the seat (5). See Fig. 2.
 4. Unlock the trigger safety (B).
 5. Depress the trigger (D) and remove the seat (5) from the gun.
- ### **⚠ CAUTION**
- Failure to depress the trigger while removing the seat may damage the needle.
6. Loosen the hexnut (E) on the needle (2) while holding the adjustment screw (A) with a screwdriver.
 7. Unscrew the needle (2) by turning the adjustment screw (A) until the needle is unthreaded.
 8. Remove the hexnut (E) and remove the needle (2) through the front of the gun.

Installation

Reassembly

1. Apply grease to the needle (2) o-rings. See Fig. 2.
2. Put the needle (2) in the gun, screwing the hexnut (E) on the needle as it is going in.
3. Start threading the adjustment screw (A) until it engages the threads of the needle (2). Continue threading until the trigger (D) raises 1/2 in. (13 mm).
4. Grease the threads of the seat (5) and the gasket (10).
5. Press the trigger (D) and install the gasket (10) and seat (5).
6. Lift the trigger (3) and lock the trigger safety.
7. Trigger adjustment:
 - a. Turn the adjustment screw (A) clockwise until the trigger (D) travels as far up as possible.
 - b. Turn the adjustment screw (A) counterclockwise until the trigger (D) stops falling, then turn an additional 1/8 turn.
 - c. Tighten the hexnut (E) against the adjustment screw (A). Hold the adjustment screw (A) to prevent it from turning. Torque the hexnut to 18–22 in-lb (2.03–2.46 N•m).
 - d. Test the trigger safety (B) to ensure that it operates properly. If the trigger safety does not operate properly, loosen the hexnut (E) and return to step 7a.
8. Screw the nozzle nut (C) and nozzle (not shown) back onto the front of the gun.

Parts

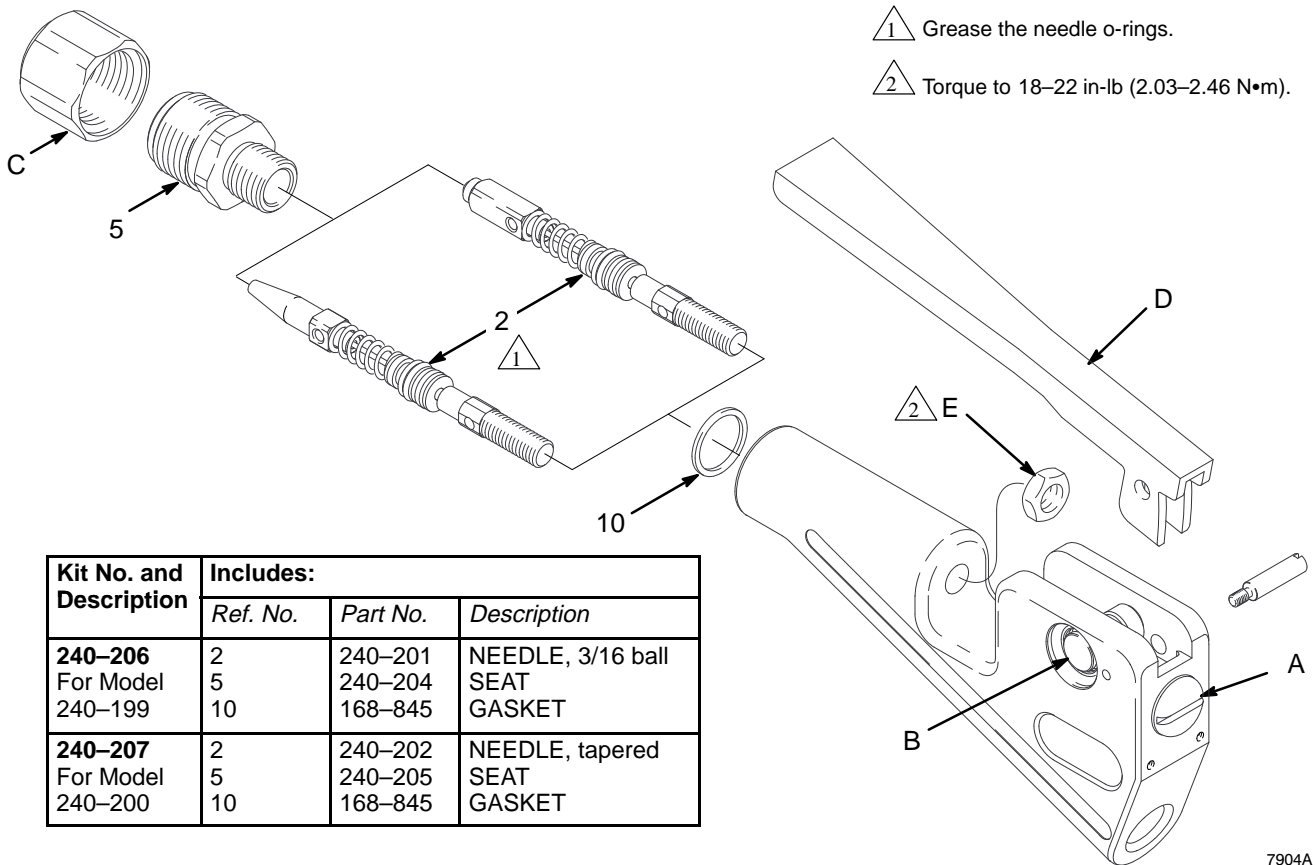

Fig. 2

7904A

Graco Standard Warranty

Graco warrants all equipment manufactured by Graco and bearing its name to be free from defects in material and workmanship on the date of sale by an authorized Graco distributor to the original purchaser for use. With the exception of any special, extended, or limited warranty published by Graco, Graco will, for a period of twelve months from the date of sale, repair or replace any part of the equipment determined by Graco to be defective. This warranty applies only when the equipment is installed, operated and maintained in accordance with Graco's written recommendations.

This warranty does not cover, and Graco shall not be liable for general wear and tear, or any malfunction, damage or wear caused by faulty installation, misapplication, abrasion, corrosion, inadequate or improper maintenance, negligence, accident, tampering, or substitution of non-Graco component parts. Nor shall Graco be liable for malfunction, damage or wear caused by the incompatibility of Graco equipment with structures, accessories, equipment or materials not supplied by Graco, or the improper design, manufacture, installation, operation or maintenance of structures, accessories, equipment or materials not supplied by Graco.

This warranty is conditioned upon the prepaid return of the equipment claimed to be defective to an authorized Graco distributor for verification of the claimed defect. If the claimed defect is verified, Graco will repair or replace free of charge any defective parts. The equipment will be returned to the original purchaser transportation prepaid. If inspection of the equipment does not disclose any defect in material or workmanship, repairs will be made at a reasonable charge, which charges may include the costs of parts, labor, and transportation.

THIS WARRANTY IS EXCLUSIVE, AND IS IN LIEU OF ANY OTHER WARRANTIES, EXPRESS OR IMPLIED, INCLUDING BUT NOT LIMITED TO WARRANTY OF MERCHANTABILITY OR WARRANTY OF FITNESS FOR A PARTICULAR PURPOSE.

Graco's sole obligation and buyer's sole remedy for any breach of warranty shall be as set forth above. The buyer agrees that no other remedy (including, but not limited to, incidental or consequential damages for lost profits, lost sales, injury to person or property, or any other incidental or consequential loss) shall be available. Any action for breach of warranty must be brought within two (2) years of the date of sale.

Graco makes no warranty, and disclaims all implied warranties of merchantability and fitness for a particular purpose in connection with accessories, equipment, materials or components sold but not manufactured by Graco. These items sold, but not manufactured by Graco (such as electric motors, switches, hose, etc.), are subject to the warranty, if any, of their manufacturer. Graco will provide purchaser with reasonable assistance in making any claim for breach of these warranties.

In no event will Graco be liable for indirect, incidental, special or consequential damages resulting from Graco supplying equipment hereunder, or the furnishing, performance, or use of any products or other goods sold hereto, whether due to a breach of contract, breach of warranty, the negligence of Graco, or otherwise.

FOR GRACO CANADA CUSTOMERS

The parties acknowledge that they have required that the present document, as well as all documents, notices and legal proceedings entered into, given or instituted pursuant hereto or relating directly or indirectly hereto, be drawn up in English. Les parties reconnaissent avoir convenu que la rédaction du présente document sera en Anglais, ainsi que tous documents, avis et procédures judiciaires exécutés, donnés ou intentés à la suite de ou en rapport, directement ou indirectement, avec les procédures concernées.

Graco Phone Number

TO PLACE AN ORDER, contact your Graco distributor, or call this number to identify the distributor closest to you:
1-800-367-4023 Toll Free

*All written and visual data contained in this document reflects the latest product information available at the time of publication.
Graco reserves the right to make changes at any time without notice.*

Sales Offices: Minneapolis, Detroit, Los Angeles
Foreign Offices: Belgium, Canada, England, Korea, France, Germany, Hong Kong, Japan

GRACO INC. P.O. BOX 1441 MINNEAPOLIS, MN 55440-1441

<http://www.graco.com>

©1998 Graco Inc. 308-857 Rev. A April 1998 PRINTED IN U.S.A.