

# INSTRUCTIONS



307-108

SEPT. 1974

This manual contains **IMPORTANT WARNINGS** and **INSTRUCTIONS**  
READ AND RETAIN FOR REFERENCE

ELECTRIC MULTI-STAGE

## IMPERIAL PUMPS

for WATER REDUCIBLE PAINTS

centrifugal supply pumps for circulating systems

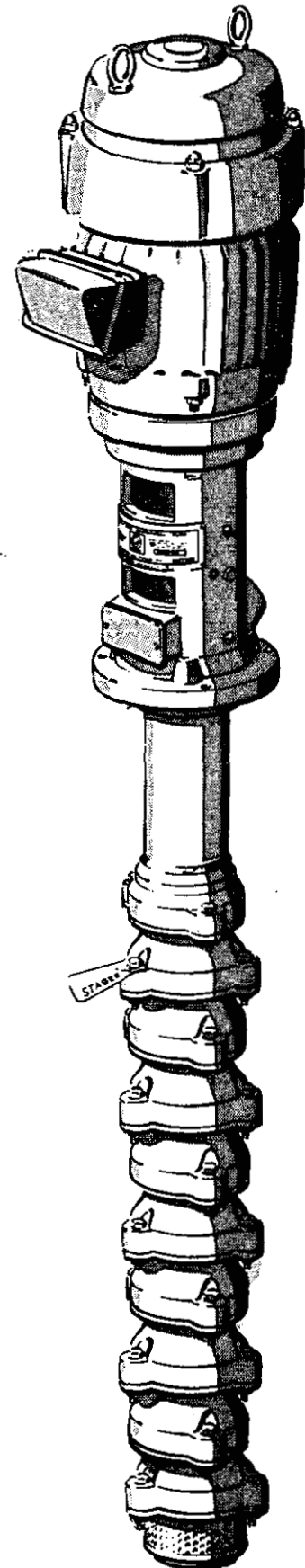

### PUMP MODELS (less motor)

| High Pressure | Number of Stages | Max. Working Press. |     | Standpipe |         |
|---------------|------------------|---------------------|-----|-----------|---------|
|               |                  | PSI                 | bar | Size      | Model   |
| 208-836       | 6                | 132                 | 9   | 66 in.    | 208-995 |
| 208-837       | 7                | 154                 | 10  | 66 in.    | 208-995 |
| 208-838       | 8                | 176                 | 12  | 66 in.    | 208-995 |
| 208-839       | 9                | 198                 | 13  | 66 in.    | 208-995 |
| 208-840       | 10               | 220                 | 15  | 66 in.    | 208-995 |
| 208-841       | 11               | 242                 | 16  | 66 in.    | 208-995 |

### MOTORS AVAILABLE FROM GRACO

| PART NO.  | HP | PHASE | VAC     | CYCLE | RPM (no load) | FRAME |
|-----------|----|-------|---------|-------|---------------|-------|
| 102-213   | 3  | 3     | 220/440 | 60    | 3600          | "T"   |
| 102-522   | 5  | 3     | 220/440 | 60    | 3600          | "T"   |
| 502-248   | 5  | 3     | 220/440 | 60    | 3600          | "U"   |
| 102-786   | 7½ | 3     | 220/440 | 60    | 3600          | "T"   |
| 103-997   | 7½ | 3     | 220/440 | 60    | 3600          | "U"   |
| 501-177   | 10 | 3     | 220/440 | 60    | 3600          | "T"   |
| 102-808   | 10 | 3     | 220/440 | 60    | 3600          | "U"   |
| * 501-050 | 15 | 3     | 220/440 | 60    | 3600          | "T"   |
| * 502-251 | 15 | 3     | 220/440 | 60    | 3600          | "U"   |

\* Adapter Kit 952-853 required for mounting 15 HP (11 186 N) motors.

### NOTE:

The size pump and motor required depends on the viscosity and characteristics of the fluid to be pumped, and upon the flow volume and pressure required in the user's system. Users should contact Graco branch or factory offices for recommendations.

TECHNICAL DATA on back page, ACCESSORIES on page 6.

# TYPICAL INSTALLATION

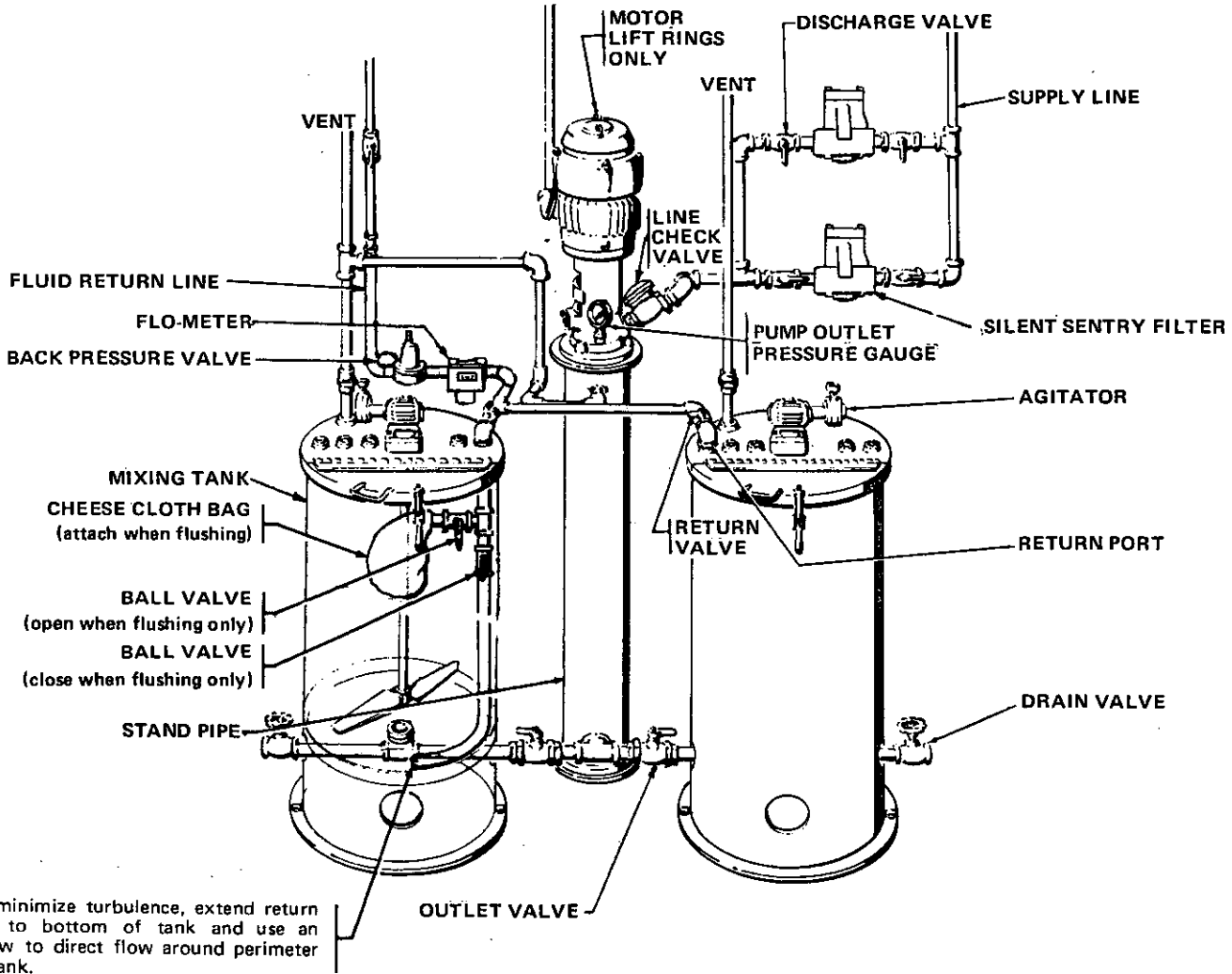

To minimize turbulence, extend return line to bottom of tank and use an elbow to direct flow around perimeter of tank.

Fig 1

# INSTALLATION

## INSTALLING A NEW CIRCULATING SYSTEM

### LINES AND RELATED EQUIPMENT

ACCESSORY EQUIPMENT needed in a circulating system is shown on page 6 of this manual. The TYPICAL INSTALLATION drawing on page 2 shows how these parts of the system are installed with relation to the pump.

Engineering assistance is available from your nearest Graco Factory branch or from the factory in Minneapolis. Because the pressure characteristics of these centrifugal pumps vary widely with flow rate, we recommend that you make use of this assistance — especially if you are going to pump material with a viscosity of 50 centipoise or more.

Plan your system to provide the most direct route to spray stations for supply and return lines. The pump outlet is 2 in. NPT (F) but line sizes should be chosen according to flow requirements and calculated pressure drop due to the length of run.

The check valve shown in the TYPICAL INSTALLATION on page 2 is a *requirement* of the system to prevent material backflow into the pump in case of power failure

or incorrect operating procedure. Install near pump outlet as shown.

Also important is that you install a pressure gauge (see drawing below) at the plugged port provided to the left of pump outlet. Use a correctly sized gauge.

Pipe or tubing and fittings must be compatible with material to be pumped. Buy and install pipe or tubing in long lengths and avoid unnecessary turns. Wherever practical, use long sweeping bends. A "Holsclaw" bender is recommended for making bends in tubing — common electricians or plumbers benders are not satisfactory. Remove burrs, dirt, etc., from ends of tubes.

When installing return lines in mix tanks, extend line to bottom of tank and use a sweep elbow to direct flow around perimeter of tank.

After all lines are installed, flush them with a compatible diluent and blow out with air, then clean all filter elements.

### MOUNT PUMP AND CONNECT CIRCULATING LINES

When mounting the pump in a standpipe installation as shown in the TYPICAL INSTALLATION on page 2, be sure the plumbing connecting the mix tanks and standpipe are the same level — use shims as necessary. Bolt standpipe and tanks firmly to the floor after installing the necessary plumbing.

Before attaching the motor to the pump, lower the pump into the standpipe (or mix tank) and attach with the four 3/8 capscrews provided — be sure the gasket is in place. For customer prepared mounting, refer to back cover for gasket number, pump length and mounting hole layout.

Connect the supply line to the outlet of the pump as shown in the TYPICAL INSTALLATION on page 2. Be sure all connections are tight.

Remove the protective cover and the shipping dowel from pump base. Take out the motor coupler and attach it loosely onto motor shaft so that coupler is flush with end of motor shaft.

Carefully lower motor onto pump base while rotating the couplers to see that they engage properly with the rubber insert. Fasten motor securely to pump base with the screws and nuts previously used to hold the protective cover on.

#### CAUTION

DON'T drop the motor onto the pump base — thrust bearings could be damaged as a result.

The lift rings on the motor are for lifting the motor only. DON'T lift the entire pump by these rings.

Adjust the motor coupler so that there is a .094" (2.39 mm) clearance between pump and motor couplers. Tighten setscrew securely. This clearance must be maintained at all times to prevent damage to thrust bearing and/or motor. See Fig 2.

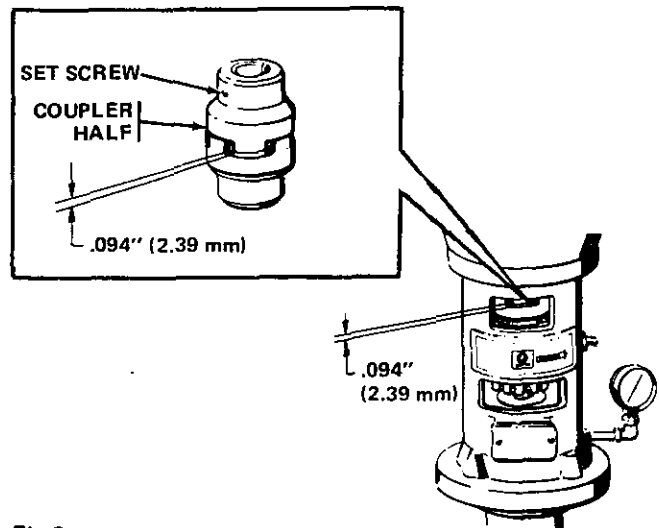

Fig 2.

Connect the motor to grounded power supply. Have a licensed electrician wire the motor in accordance with applicable safety codes in your area. See TECHNICAL DATA on back page for power requirements. After motor is connected, start it to see that rotation direction is correct as indicated on the identification — instruction plate.

## OPERATION

### CLEANING, FLUSHING AND PRIMING SYSTEM

#### CAUTION

1. Don't let the pump run dry.
2. Be sure motor rotates correctly and drive coupler clearance is set at .094" (2.39 mm).
3. Be sure that circulating lines are flushed clean and primed with material as instructed below.
4. If the motor labors or the pump doesn't run smoothly, check motor for high amp draw and thrust bearing for overheating. See table on back page for maximum amp draw. Normal operating temperature is from 120° to 150° F (49°-65° C). If amp draw is high or temperature is higher than 150° F (65° C), consult qualified Graco personnel after repeat check of drive coupler clearance.

The procedure given here is for a standpipe - mounted pump, two mix tank system as shown in the typical installation. However, flushing procedures would be the same for other systems except for some specific instructions which, naturally, might not apply. This flushing procedure is important in order to clean all equipment and lines of impurities and purge all the air out of the system. Following these instructions faithfully will assure satisfactory operation with quality control.

Clean inside of mix tanks. Close outlet valves of both tanks and put about 100 gallons (378 l) of your materials diluting agent into each tank. Open the outlet valve on one tank only.

Attach a cheese cloth bag of six layers minimum thickness to return line in tank as shown in Fig 1 on page 2.

Start the pump and let it run for two minutes with at least 50 psi (3.5 bar) outlet pressure, then stop it. Recheck drive coupler for .094" (2.39 mm) clearance. *This is important.* The pump coupler and bearing could move up during shipment, then, when pump is operated, move down, leaving too much clearance. This could damage the coupler insert and the coupler.

Restart pump and check entire system for leaks. Tighten all leaking joints as necessary to stop leaks. Continue circulating, changing cheese cloth bags and diluting agent as often as necessary, until system is thoroughly cleaned. Periodically check for leaks during flushing.

When system is clean, disconnect return line from back pressure valve and direct line into an empty waste container. Drain all filtered residue from filters.

Close outlet and return valves for the tank you have been using and open outlet and return valves for the other tank. Start pump and circulate diluting agent for at least one hour, changing cheese cloth bags as necessary. While circulating, open each spray gun drop and flush hoses with about one gallon (3.8 l) of diluting agent. Also open filter drain valves to flush out all filtered residue.

When flushing is complete, stop pump and drain all diluting agent from tanks and lines. Thoroughly blow out entire system with clean, dry compressed air, or with nitrogen to remove all diluting agent from system.

Fill tank with coating material and start agitator. Start pump and circulate material until all air has been removed from system. While material is circulating, check and adjust viscosity as necessary.

Fill the other mixing tank with material and start agitator. Leave agitator running, so that material in standby tank will be ready for use when needed. To keep air out of system, always switch to the standby tank before the material supply in the tank you have been using is completely exhausted.

Consult material supplier for compatible solvent for flushing paint from system. Water reducible paints should use deionized water and a solvent which will keep resin in solution. If water reducible paint has 20% solvent content, flush media should also contain approximately 20% solvent.

### ADJUSTING SYSTEM PRESSURE

Use the back pressure valve to adjust system pressure. Determine the line pressure required and, with material circulating in line loop only, set the back pressure valve so that the pressure at the last spray gun is 10 psi (.7 bar) greater than needed. Refer to the "TYPICAL INSTALLATION" drawing on page 2 and separate back pressure valve instructions.

The available pressure at the pump is shown by the gauge installed at the pump base ahead of the main line shut off valve and filters. See page 2.

#### CAUTION

The pump is set at factory to deliver maximum outlet pressure. Pressure cannot be increased by any adjustment of pump. *Unauthorized field adjustment will void factory warranty.* Should excess system pressure be exhibited, contact your nearest qualified Graco representative or authorized service/distribution center for assistance.

## LUBRICATION

The thrust bearing is lubricated from the top by pumping one or two shots -- about 0.1 oz (.003 l) of specified grease through the fitting on top of the seal retainer once a month if the pump is operating continuously. See Fig 3.

Grease must be Chevron SRI/ No. 2 NLGI grade; which is used for the factory pack; or a compatible No. 2 premium ball bearing grease which complies with Graco specification No. 70321. The recommended grease has a 300° F (149° C) temperature rating and an oil viscosity of 600 SSU at 100° F (38° C). Greases with EP additives should be avoided.

**NOTE:** High temperature on the housing by the thrust bearing may indicate failure of the thrust bearing. Normal temperatures on the housing are below 120° F (49° C). When temperatures above 150° F (65° C) on the housing are observed, stop pump immediately and contact the authorized Graco distributor from whom equipment was purchased.

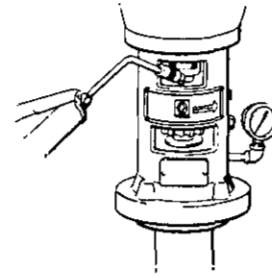

Fig 3

## SERVICE

Service instructions for the motor are given in separate manufacturer's literature.

The following SERVICE DIAGNOSIS chart lists the things that should be done to correct specific troubles.

### TROUBLE SHOOTING CHART

#### WHAT'S WRONG

PUMP WON'T RUN

PUMP RUNS BUT PRESSURE DROPS SOME

PUMP RUNS BUT PRESSURE VERY LOW OR UNSTEADY

MATERIAL LEAKING

**WARNING**

Before removing pump for repair, shut the electric power off and relieve pressure.

#### CAUTION:

Do not attempt to make any repairs to the inside of the pump. Special instructions and tools are required for correct disassembly and assembly. If you have a competent service man, contact your local Graco representative or the Minneapolis Factory Service Department for special instructions and tools required.

#### WHY

- Electric power out
- Fuses blown
- Motor inoperative
- Clogged intake screen
- Increased flow rate
- Clogged inlet screen
- Bolts or fittings loose
- Parts worn or damaged
- Clogged by-pass drain

#### WHAT TO DO

- Check fuses, clean terminals and connections
- Check coupler clearance, repair pump (call Graco)
- Repair or replace motor
- Remove and clean
- Adjust back pressure valve
- Clean\*
- Tighten
- Repair (call Graco)\*\*
- Open

\*Before removing pump for cleaning, close the line valve and note maximum pump pressure. The pressure should be steady. If variations or pulsations are noted, the inlet flow to the pump is restricted; due either to a clogged screen or too low fluid level in the standpipe or too restricted plumbing. Correct clogged conditions to obtain steady pressure.

Connect diluting agent pump to pump outlet or gauge port, turn off main line and mix tank valves and open connections at bottom of standpipe. Start diluting agent pump. If screen cannot be cleaned by this "reverse flush" method, pump MUST be removed from system for disassembly and cleaning.

**CAUTION:** Don't leave discharge valve closed for more than 2 or 3 minutes -- material in standpipe will heat up and pump will lose efficiency and pressure.

\*\* Parts shown in Fig 4 should be replaced at yearly intervals.

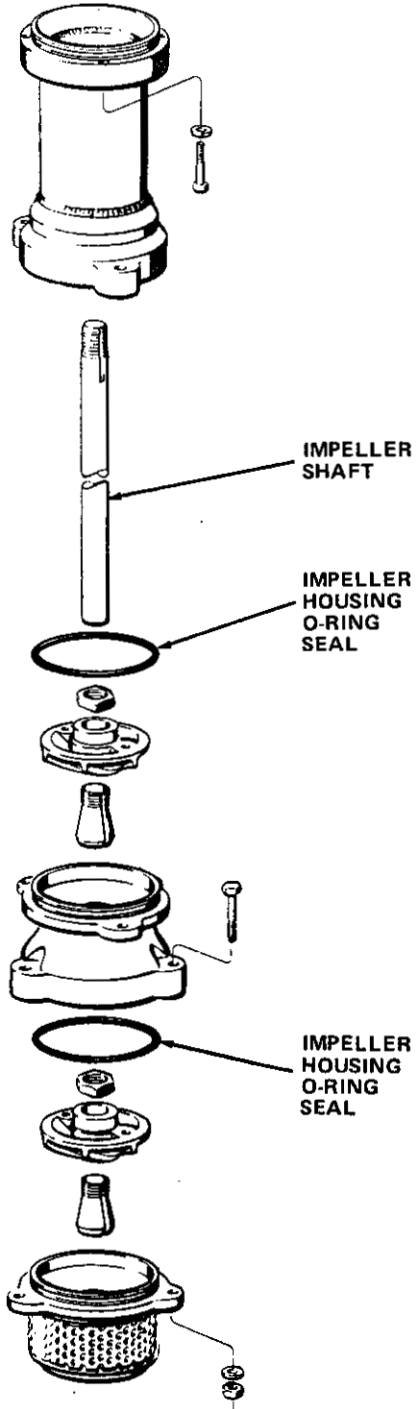
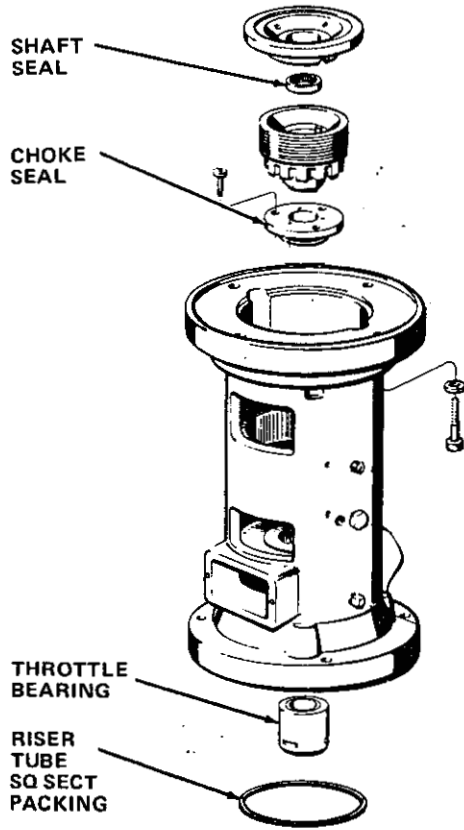
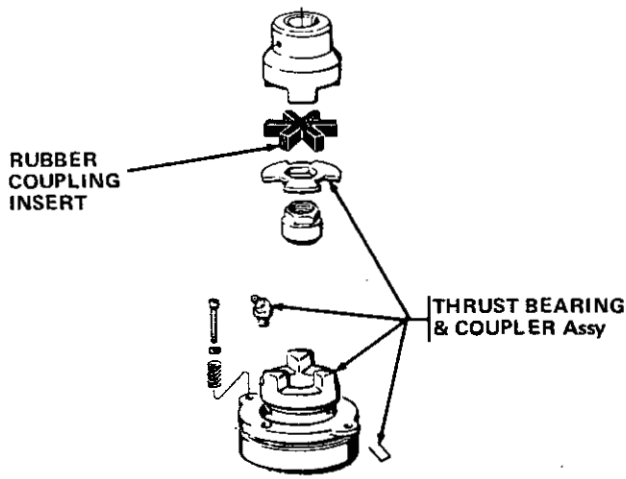

**CAUTION**

Do not attempt to make any repairs to the inside of the pump. Special instructions and tools are required for correct disassembly and assembly. If you have a competent service man, contact your local Graco representative or the Minneapolis Factory Service Department for special instructions and tools required.

Fig. 4

**ACCESSORIES (Must be purchased separately)**

**STANDPIPE 208-995**

66" Standpipe. Use with mixing tanks or containers not over 58" high. Pump mounting gasket included.



**MIXING TANKS and AGITATORS**

80, 120 and 150 gal

Available on special order from Graco Fluid Systems Division.



**NOTE**

Check valves with 2" NPT thread are available from jobber's stock. Pressure rating of all valves and plumbing used must be higher than the pressure rating of the pump being installed.

**CHECK VALVE 103-772**

275 psi (19 bar) maximum working pressure

Swing Type

2" NPT Both Ends

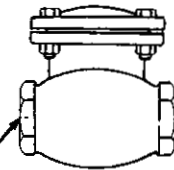

**BACK PRESSURE VALVE 208-997**

180 psi (12 bar) maximum working pressure



**FLO-METERS**

- 103-998 Stainless Steel: left to right flow
- 104-025 Nickle Plated: left to right flow
- 104-138 Nickle Plated: right to left flow

300 psi (21 bar) maximum working pressure

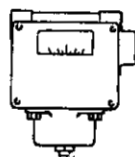
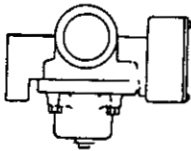

**SILENT SENTRY FILTER 103-984**

300 psi (21 bar) maximum working pressure

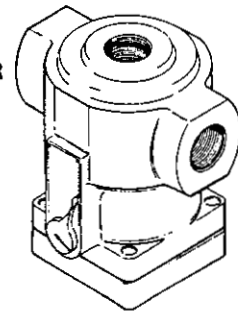

**FLUID PRESSURE GAUGE and PULSATION DAMPENER 208-855**

Stainless Steel wetted parts  
300 psi (21 bar) maximum working pressure



## TECHNICAL DATA

|                         |  |
|-------------------------|--|
| Power supply required   | 220/440 volt AC; 3 phase, 60 cycle         |
| Approx. current draw    | (See chart below)                          |
| Max. shut off pressures | 22 psi (1.5 bar) per stage                 |
| Flow rate               | 0-50 gpm (0-189 l)                         |
| Fluid outlet size       | 2 NPT (F)                                  |
| Wetted parts            | Bronze; Stainless Steel;<br>Nitrile rubber |

## ELECTRICAL REQUIREMENTS

| Motor Size      | FULL-LOAD AMPERES PER PHASE MAX. |           | MAX. STARTING AMPS. PER PHASE |           |
|-----------------|----------------------------------|-----------|-------------------------------|-----------|
|                 | 220 Volts                        | 440 Volts | 220 Volts                     | 440 Volts |
| 5 hp (3728 N)   | 14.35                            | 7.2       | 90                            | 45        |
| 7.5 hp (5593 N) | 20                               | 10        | 120                           | 60        |
| 10 hp (7457 N)  | 27                               | 13.5      |                               |           |

NOTE: On 208 volt 3 phase circuits, the ampere values will be about 1.06 times the values for 220 volts.

NOTE: Larger motors are necessary on some installations. See motor manufacturers data for electrical load

## PUMP DIMENSIONAL DRAWING

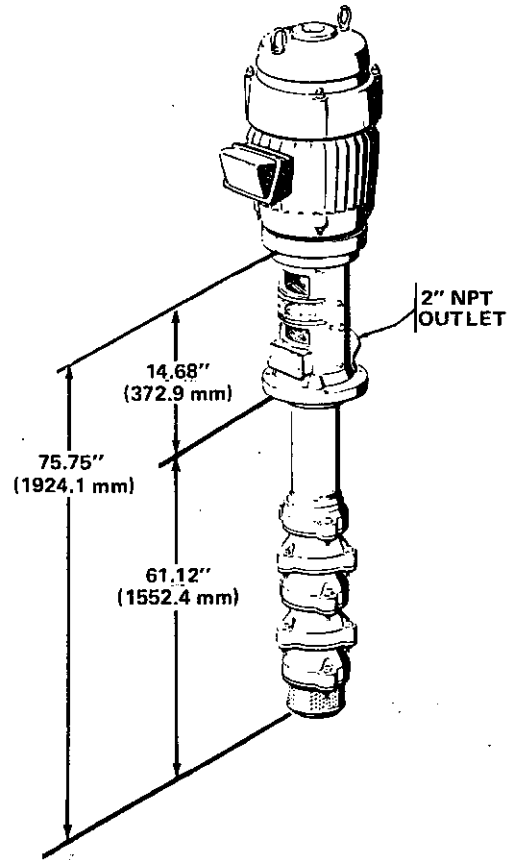

| PUMP MODEL | WEIGHT          |
|------------|-----------------|
| 208-836    | 210 lb (95 kg)  |
| 208-837    | 221 lb (100 kg) |
| 208-838    | 232 lb (105 kg) |
| 208-839    | 243 lb (110 kg) |
| 208-840    | 254 lb (115 kg) |
| 208-841    | 265 lb (120 kg) |

## THE GRACO WARRANTY

Graco Inc. warrants all equipment manufactured by it and bearing its name to be free from defects in material and workmanship under normal use and service. Scope of this warranty extends to the original purchaser for a period of 12 months from the date of purchase and is applicable only when the equipment is installed and operated in accordance with factory recommendations. The warranty does not extend to damage or wear caused by misuse, abrasion, corrosion, negligence, accident, faulty installation or tampering in a manner to impair its normal operation.

In the event the equipment supplied by Graco Inc. is found to be defective within the above-stated 12-month period, Graco Inc. will repair or replace free of charge such defective parts if rendered prepaid to the factory or to an authorized Graco service agency and is found by Graco Inc.'s inspection to be truly defective in workmanship or material. In the event said material is deemed defective in workmanship or material, it will be corrected and shipped transportation prepaid within the continental U.S. If inspection of any such equipment by Graco Inc. does not disclose any defect in workmanship or material, repairs will be made at a reasonable charge. Purchased assemblies which are incorporated into Graco equipment, carry the manufacturer's regular warranty.

The foregoing warranties are exclusive, and are in lieu of all other warranties (whether written, oral or implied) including warranty of merchantability in other respects than expressly set forth above and warranty of fitness for a particular purpose. Except as herein provided, every form of liability for direct or consequential damages or loss is expressly excluded and denied.

## MOUNTING HOLE LAYOUT

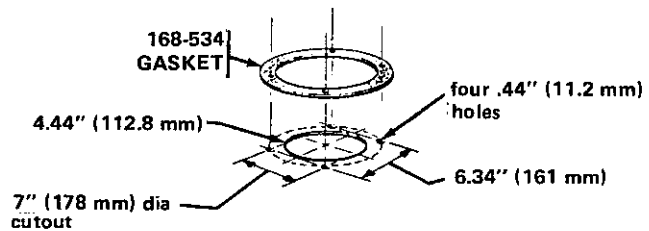

Factory Branches: ATLANTA, CHICAGO, (Broadview), CLEVELAND, DALLAS, DETROIT (Southfield), LOS ANGELES, SOUTH SAN FRANCISCO, WEST CALDWELL (N.J.).  
 Subsidiary and Affiliate Companies: CANADA; ARGENTINA; BRAZIL; VENEZUELA; ENGLAND; FRANCE; GER-  
 MANY; ITALY; SWITZERLAND; SWEDEN; HONG KONG; JAPAN

**GRACO INC. P.O. BOX 1441 Minneapolis, MN 55440**

307-108  
 Sept., 1974  
 PRINTED  
 IN  
 U.S.A.