



This manual contains important warnings and information.
READ AND KEEP FOR REFERENCE.

INSTRUCTIONS

GRACO
First choice when quality counts.™

Rev. D
Supersedes Rev. C

35:1 Ratio Senator® Pump

4200 psi (29.0 MPa, 290 bar) Maximum Working Pressure

120 psi (0.8 MPa, 8 bar) Maximum Air Input Pressure

Model 218-048, Series A

With Severe-Duty Displacement Pump*

* Severe-Duty Displacement Pumps have an abrasion and corrosion resistant displacement rod and sleeve. Refer to the **Technical Data** in the displacement pump manual 307-650 for "wetted parts" information.

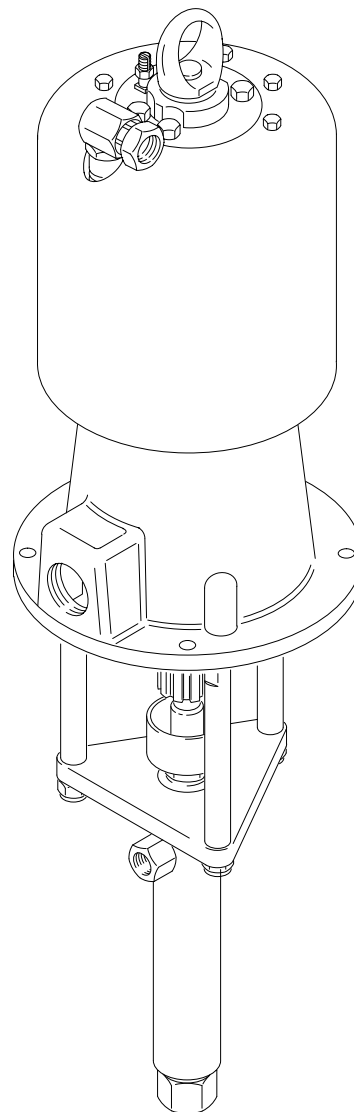

Table of Contents

Symbols	2
Warnings	2
Installation	4
Typical Installation	5
Operation	6
Maintenance	8
Troubleshooting	9
Service	11
Parts	13
Dimensions	15
Mounting Hole Layout	15
Technical Data	15
Warranty	16
Graco Phone Number	16

7595A

Symbols

Warning Symbol



This symbol alerts you to the possibility of serious injury or death if you do not follow the instructions.

Caution Symbol



This symbol alerts you to the possibility of damage to or destruction of equipment if you do not follow the corresponding instructions.

! WARNING



INJECTION HAZARD

Spray from the gun, hose leaks, or ruptured components can inject fluid into your body and cause an extremely serious injury, including the need for amputation. Splashing fluid in the eyes or on the skin can also cause a serious injury.

- Fluid injected into the skin might look like just a cut, but it is a serious injury. **Get immediate medical attention.**
- Do not point the spray gun/dispensing valve at anyone or at any part of the body.
- Do not put hand or fingers over the spray tip/nozzle.
- Do not stop or deflect fluid leaks with your hand, body, glove, or rag.
- Do not “blow back” fluid; this is not an air spray system.
- Always have the tip guard and the trigger guard on the spray gun/dispensing valve when spraying/dispensing.
- Be sure the gun trigger safety operates before spraying.
- Lock the gun/valve trigger safety when you stop spraying.
- Follow the **Pressure Relief Procedure** on page 6 whenever you: are instructed to relieve pressure; stop spraying; clean, check, or service the equipment; and install or clean the spray tip.
- Tighten all the fluid connections before operating the equipment.
- Check the hoses, tubes, and couplings daily. Replace worn, damaged, or loose parts immediately. Permanently coupled hoses cannot be repaired; replace the entire hose.



TOXIC FLUID HAZARD

Hazardous fluids or toxic fumes can cause a serious injury or death if splashed in the eyes or on the skin, swallowed, or inhaled.

- Know the specific hazards of the fluid you are using. Read the fluid manufacturer’s warnings.
- Store hazardous fluid in an approved container. Dispose of the hazardous fluid according to all local, state, and national guidelines.
- Wear appropriate protective clothing, gloves, eyewear, and respirator.

Warnings are continued on the next page.

⚠ WARNING



FIRE AND EXPLOSION HAZARD

Improper grounding, poor air ventilation, open flames, or sparks can cause a hazardous condition and result in fire or explosion and serious injury.

- Ground the equipment and the object being sprayed/dispensed. See **Grounding** on page 4.
- Provide fresh air ventilation to avoid the buildup of flammable fumes from solvent or the fluid being sprayed.
- Extinguish all the open flames or pilot lights in the spray/dispensing area.
- Electrically disconnect all the equipment in the spray/dispensing area.
- Keep the spray/dispensing area free of debris, including solvent, rags, and gasoline.
- Do not turn on or off any light switch in the spray/dispensing area while operating or if fumes are present.
- Do not smoke in the spray/dispensing area.
- Do not operate a gasoline engine in the spray/dispensing area.
- If there is any static sparking while using the equipment, **stop spraying/dispensing immediately**. Identify and correct the problem.



INSTRUCTIONS



EQUIPMENT MISUSE HAZARD

Equipment misuse can cause the equipment to rupture, malfunction, or start unexpectedly and result in a serious injury.

- This equipment is for professional use only.
- Read all the instruction manuals, tags, and labels before operating the equipment.
- Use the equipment only for its intended purpose. If you are uncertain about usage, call your Graco distributor.
- Do not alter or modify this equipment. Use only genuine Graco parts and accessories.
- Check the equipment daily. Repair or replace worn or damaged parts immediately.
- Do not exceed the maximum working pressure of the lowest rated system component. This equipment has a **4200 psi (29.0 MPa, 290 bar) maximum working pressure**.
- Use fluids that are compatible with the equipment wetted parts. See the **Technical Data** section of all the equipment manuals. Read the fluid manufacturer's warnings.
- Route the hoses away from traffic areas, sharp edges, moving parts, and hot surfaces. Do not expose Graco hoses to temperatures above 180°F (82°C) or below -40°F (-40°C).
- Do not use the hoses to pull equipment.
- Wear hearing protection when operating this equipment.
- Comply with all applicable local, state, and national fire, electrical, and other safety regulations.



MOVING PARTS HAZARD

Moving parts, such as the air motor piston, can pinch or amputate fingers.

- Do not operate the equipment with the air motor shield removed.
- Keep clear of any moving parts when starting or operating the equipment.

Installation

General Information



NOTE: Reference numbers and letters in parentheses in the text refer to the callouts in the figures and the parts drawing.

NOTE: Always use Genuine Graco Parts and Accessories, available from your Graco distributor.

Grounding

⚠ WARNING

FIRE AND EXPLOSION HAZARD
Before operating, ground the system as explained below. Also read the section **FIRE AND EXPLOSION HAZARD** on page 3.



To reduce the risk of static sparking, ground the pump and all other components used or located in the spray/dispensing area. Check your local electrical code for detailed instructions for your area and type of equipment and be sure to ground all of these components.

- **Pump:** loosen the grounding lug locknut (W) and washer (X). Insert one end of a 12 ga (1.5 mm²) minimum ground wire (Y) into the slot in lug (Z) and tighten the locknut securely. See Fig. 1. Connect the other end of the wire to a true earth ground. Order Part No. 237–569 Ground Wire.
- **Air and Fluid Hoses:** Use only electrically conductive hoses with a maximum of 500 feet (150 m) combined hose length to ensure grounding continuity.
- **Air Compressor:** follow the air compressor manufacturer's recommendations
- **Spray gun/dispensing valve:** obtain grounding through connection to a properly grounded fluid hose and pump.

- **Fluid supply container:** according to local code.
- **Object being sprayed:** according to local code.
- **All solvent pails** used when flushing, according to local code. Use only metal pails, which are conductive. Do not place the pail on a non-conductive surface, such as paper or cardboard, which interrupts grounding continuity.
- **To maintain grounding continuity when flushing or relieving pressure,** always hold a metal part of the gun firmly to the side of a grounded metal pail, then trigger the gun.

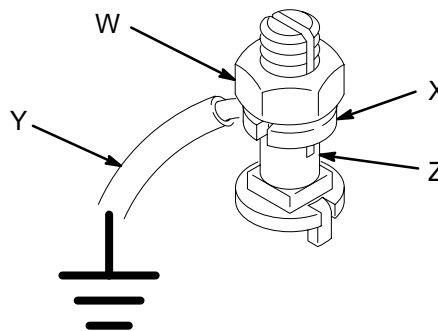

0864

Fig. 1

Flushing Safety

⚠ WARNING

To reduce the risk of serious injury whenever you are instructed to relieve pressure, always follow the **Pressure Relief Procedure** on page 6.

Before flushing, be sure the entire system and flushing pails are properly grounded. Refer to **Grounding** at left. Follow the **Pressure Relief Procedure** on page 6, and remove the spray tip/nozzle from the gun/dispensing valve. Always use the lowest possible fluid pressure, and maintain firm metal-to-metal contact between the gun/dispensing valve and the pail during flushing to reduce the risk of fluid injection injury, static sparking, and splashing.

Installation

Typical Installation

Key

- A Air Line Filter
- B Air Line Lubricator
- C Bleed Type Master Air Valve (Required)
- D Air Regulator
- E Fluid Drain Valve (Required)
- F Suction Tube Kit
- G Fluid Filter
- H Electrically Conductive Fluid Hose
- J Pump Intake
- K Electrically Conductive Air Hose
- L Ground Wire
- M Pump Runaway Valve
- N Optional Fluid Outlet
- P Airless Spray Gun

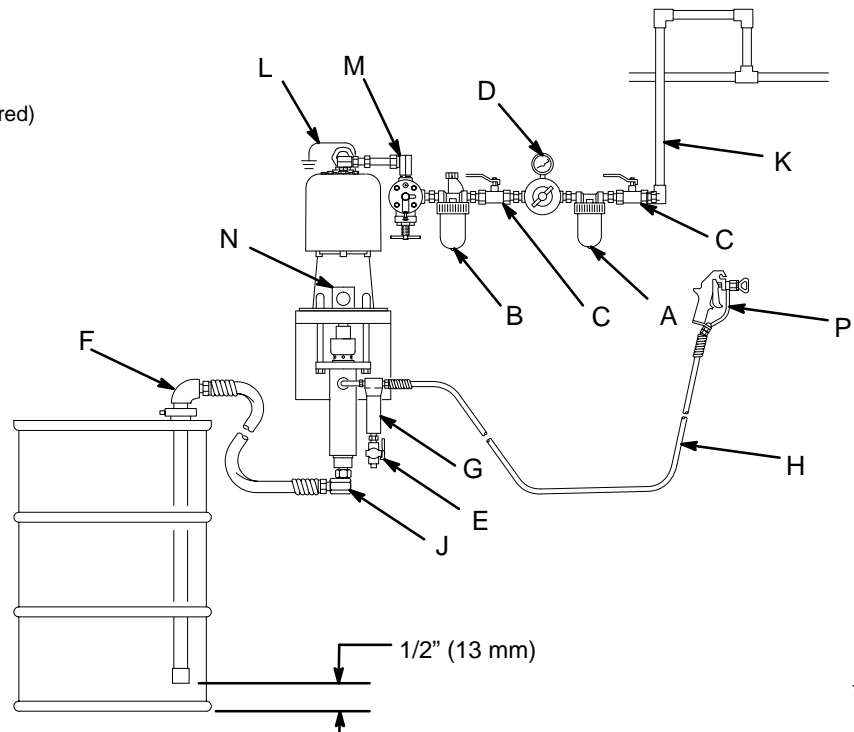

7596A

The Typical Installation above is only a guide to selecting and installing required and optional accessories. For assistance in designing a system to meet your needs, contact your Graco distributor.

The dimensional drawing on page 15 gives measurements needed for installing the pump on a custom designed mounting.

System Accessories

Install the air line accessories in the order shown in the Typical Installation. Working upstream from the pump air inlet, install a pump runaway valve (M) to shut off the air to the pump if the pump accelerates beyond the preadjusted setting. A pump which runs too fast can be seriously damaged.

Next, install an air line lubricator (B) for automatic air motor lubrication, a bleed-type master air valve (C) to relieve air trapped between the valve and the pump, and air regulator (D) to control pump speed, and an air filter (A) to remove harmful dirt and moisture from the compressed air supply. Install another bleed-type master air valve (C) to isolate the accessories for servicing.

Be sure the air line (K) is electrically conductive, and is large enough to supply an adequate volume of air to the motor.

Downstream from the pump, in the fluid line, install a fluid filter (G) and fluid drain valve (E). Connect an electrically conductive fluid hose (H) and a spray gun or dispensing valve to the pump. Do not install the spray tip in a spray gun yet.

⚠ WARNING

Two accessories, the bleed-type air shutoff valve (C) and the fluid drain valve (E) are required for your system to reduce the risk of serious injury from moving parts, splashing, or fluid injection when shutting off the pump.

The bleed-type master air valve relieves air trapped between this valve and the pump after the pump is shut off. Trapped air can cause the pump to cycle unexpectedly and result in serious injury if you are adjusting or repairing the pump.

The fluid drain valve assists in relieving fluid pressure in the displacement pump, hose, and gun/dispensing valve. Triggering the gun to relieve pressure may not be sufficient, especially if there is a clog in the hose, gun/dispensing valve, or tip/nozzle.

Connect a suction hose and tube (F) to the 1 in. npt(f) intake (J) of the pump.

NOTE: To use the 1-1/2 in. npt optional fluid outlet (N) at the base of the air motor, connect a riser tube between the standard outlet and the optional outlet.

Operation

WARNING

To reduce the risk of serious injury, never operate the pump with the air motor shield removed. The moving piston behind the shield can pinch or amputate fingers.

Pressure Relief Procedure

WARNING



INJECTION HAZARD

Fluid under high pressure can be injected through the skin and cause serious injury. To reduce the risk of an injury from injection, splashing fluid, or moving parts, follow the **Pressure Relief Procedure** whenever you:

- are instructed to relieve the pressure,
- stop spraying,
- check or service any of the system equipment,
- or install or clean any part of the system.

2. Shut off the air to the pump.
3. Close the bleed-type master air valve (required in your system).
4. Unlock the trigger safety.
5. Hold a metal part of the gun/dispensing valve firmly to the side of a grounded metal pail, and trigger the gun/dispensing valve to relieve pressure.
6. Lock the trigger safety.
7. Open the drain valve (required in your system), having a container ready to catch the drainage.
8. Leave the drain valve open until you are ready to spray again.

If you suspect that the spray tip/nozzle is completely clogged, or that pressure has not been fully relieved after following the steps above, very slowly loosen the retaining nut or hose end coupling and relieve pressure gradually, then loosen completely. Now clear the tip/nozzle or hose.

1. Lock the trigger safety.

Operation

Flush the Pump Before Using

WARNING

To reduce the risk of serious injury whenever you are instructed to relieve pressure, always follow the **Pressure Relief Procedure** on page 6.

Pumps are tested with lightweight oil which is left in to protect pump parts. To prevent contamination of fluid, flush the pump with a compatible solvent before using it. If the pump is being used to supply a circulating system, allow the solvent to circulate until the pump is thoroughly flushed.

Keep the wet-cup (S) filled with Graco Throat Seal Liquid (TSL) to help prolong the packing life. Check the tightness of the packing nut (S) weekly. The packing nut should be tight enough to prevent leakage, but no tighter. See Fig. 2. Always **relieve the pressure** before adjusting the packing nut.

Starting and Adjusting the Pump

Do not install the spray tip yet.

Open the bleed-type master air valve, trigger the spray gun into a grounded metal waste container, and slowly open the air regulator until the pump starts to cycle [about 20 psi (140 kPa, 1.4 bar)]. Allow the pump to cycle slowly until all the air is purged from the fluid lines. The lines are purged when the fluid emitted from the gun is flowing in a steady stream. The pump will stall against pressure when the gun trigger is released.

Relieve the pressure.

With pump line primed, and with adequate air pressure and volume supplied, the pump will start and stop as the spray gun is triggered and released. In a circulating system, it will run continuously and speed up or slow down as supply demands until the air supply is shut off.

Use an adequate sized air regulator to control pump speed and failed pressure. Always use the lowest air pressure necessary to give you the results you want. Higher pressures waste fluid and cause premature wear of the pump packings and spray tip.

WARNING

To reduce the risk or serious injury, including fluid injection and splashing in the eyes or on the skin, and property damage, never exceed the maximum air and fluid working pressure of the lowest rated component in your system.

Never allow the pump to run dry of the fluid being pumped. A dry pump will quickly accelerate to a high speed, possibly damaging itself. (A pump runaway valve automatically alerts you to this problem). If your pump accelerates quickly, or is running too fast, stop it immediately and check the fluid supply. If the supply container is empty and air has been pumped into the lines, refill the supply container and prime the pump and lines with fluid being sure to eliminate all air from the fluid system, or flush the pump as described in **Shutdown and Care of the Pump** on page 8.

Maintenance

Shutdown and Care of the Pump

WARNING

To reduce the risk of serious injury whenever you are instructed to relieve pressure, always follow the **Pressure Relief Procedure** on page .

Relieve the pressure whenever you shut off the pump. Stop the pump at the bottom of its stroke to keep fluid from drying on the exposed displacement rod and damaging the throat packings.

Always flush the pump before the fluid dries in the pump and hoses. If the pump is to be stored for any period of time, and you are pumping water based fluid, first flush it with water, then with mineral spirits to protect the pump parts.

Flushing

WARNING

To reduce the risk of serious injury whenever you are instructed to relieve pressure, always follow the **Pressure Relief Procedure** on page 6.

Relieve the pressure. Remove the spray tip (spray guns or spray valves only) before flushing. Hold a metal part of the gun/valve firmly to the side of a grounded metal pail and use the lowest possible fluid pressure during flushing.

Lubrication

The accessory air line lubricator (B) provides automatic air motor lubrication. For daily, manual lubrication, disconnect the regulator, place about 15 drops of light machine oil in the pump air inlet, reconnect the regulator, and turn on the air supply to blow oil into the motor.

Corrosion Protection

WARNING

To reduce the risk of serious injury whenever you are instructed to relieve pressure, always follow the **Pressure Relief Procedure** on page 6.

CAUTION

Water, or even moist air can cause your pump to corrode. To help prevent corrosion, never leave the pump filled with water or air. After normal flushing, flush the pump again with mineral spirits or oil-based solvent, **relieve the pressure** and leave the mineral spirits in the pump.

Troubleshooting

WARNING

To reduce the risk of serious injury whenever you are instructed to relieve pressure, always follow the **Pressure Relief Procedure** on page 6.

Before servicing this equipment always make sure to **Relieve the Pressure**.

Note: Check all possible causes and solutions before disassembling the pump.

Problem	Cause	Solution
Pump fails to operate.	Restricted line or inadequate air supply.	Clear line or increase line size.
	Insufficient air pressure; closed or clogged air valves, etc.	Open air valve, clean if necessary.
	Exhausted fluid supply.	Refill; purge all air from pump and fluid lines.
	Damaged air motor.	Service. See air motor instruction manual 307–592.
	Dried fluid seizure of displacement rod.	Clean, check or replace throat packings; always stop pump at bottom of stroke and keep TSL in wet-cup.
Pump operates, but output low on both strokes.	Restricted line, or inadequate air line supply.	Clear line or increase line size.
	Insufficient air pressure. Closed or clogged air valves, etc.	Open air valves, clean if necessary.
	Obstructed fluid line, valves, gun, etc.	Clear*.
	Tight throat packing nut.	Loosen. See page 7.
Pump operates, but output low on downstroke.	Held open or worn fluid intake valve.	Clear, service. See instruction manual 307–650.
Pump operates, but output low on upstroke.	Held open or worn fluid piston valve or packing leaking.	Clear, service. See instruction manual 307–650.
Erratic or accelerated operation.	Exhausted fluid supply.	Refill; purge all air from pump and fluid lines.
	Held open or worn fluid intake valve.	Clear, service. See instruction manual 307–650.
	Held open or worn piston valve or packing leaking.	Clear, service. See instruction manual 307–650.

* **Relieve the pressure** and disconnect the fluid line. If the pump starts again when air is turned on, the line, etc., is clogged.

Service

WARNING

To reduce the risk of serious injury whenever you are instructed to relieve pressure, always follow the **Pressure Relief Procedure** on page 6.

Disconnect the Pump from the Air Motor

Relieve the pressure. Disconnect the fluid line from the fluid outlet of the pump. Unscrew the coupling nut (4) from the air motor. See Fig. 2. Unscrew the locknuts (8) from the tie rods (14) and remove the displacement pump from the air motor. Remove the cotter pin (7) from the connecting rod (16) and screw the connecting rod off the displacement pump. Remove the cotter pin (7) from the connecting rod (16) and screw the connecting rod off the displacement pump. Remove the o-ring (6) from the displacement rod of the pump.

Refer to instruction manual 307–650 for displacement pump service instructions.

Refer to instruction manual 307–592 for air motor service instructions.

Connect the Pump to the Air Motor

Relieve the pressure. Apply lithium base grease to the o-ring (6) and install it on the connecting rod (16). Apply lithium base grease to the threads of the displacement rod and screw the connecting rod onto the displacement rod until the holes in both pieces are aligned. Install the cotter pin (7). See Fig. 2. Connect the displacement pump to the air motor using the three tie rods (14) and locknuts (8). Torque the locknuts to 40–50 ft-lb (54–68 N•m). Screw the coupling nut (4) onto the air motor piston rod and tighten securely.

Note: If the ground wire was disconnected before servicing, be sure to reconnect before operating the pump, and check to be sure the entire system is properly grounded.

 Torque to 40–50 ft-lb (54–68 N•m)

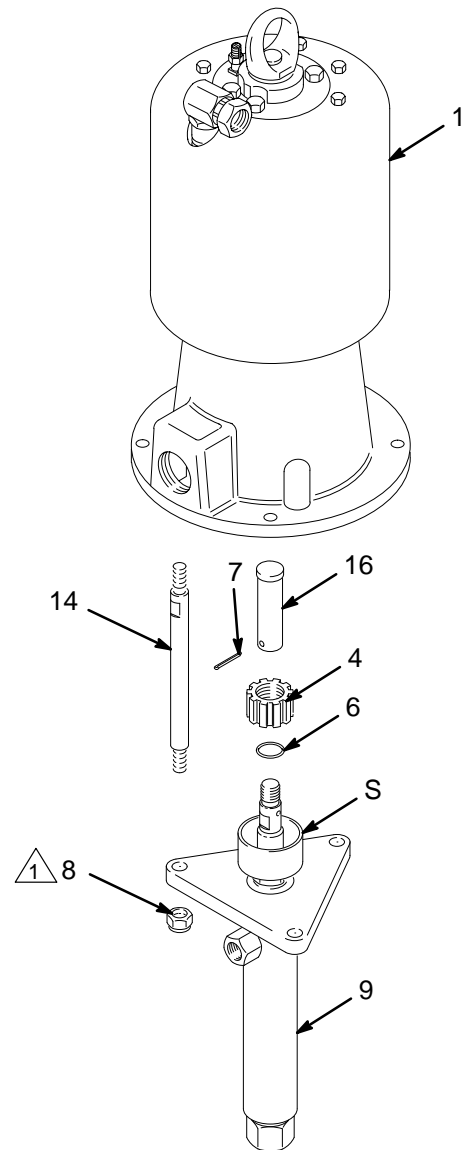
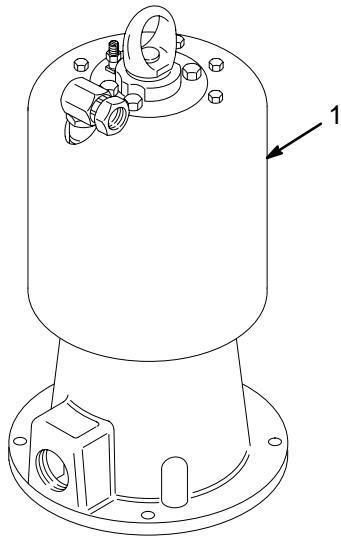

Fig. 2

7594A

Parts



Ref No.	Part No.	Description	Qty.
1	217-540	AIR MOTOR See manual 307-592 for parts	1
4	161-544	NUT, shouldered	1
6	158-674	O-RING; buna-N	1
7*	100-103	PIN, cotter; 0.125 in. x 1.5 in.	1
8	101-712	NUT, lock; with nylon inserts; 5/8 x 11	3
9	217-462	DISPLACEMENT PUMP ASSY. See manual 307-650 for parts	1
11	172-479	TAG, warning (not shown)	1
12	172-447	LABEL, warning	1
14	167-544	ROD, tie; 8" (203 mm) shoulder to shoulder	3
16	180-164	ROD, connecting	1

* Recommended Tool Box spare parts. Keep on hand to reduce down time.

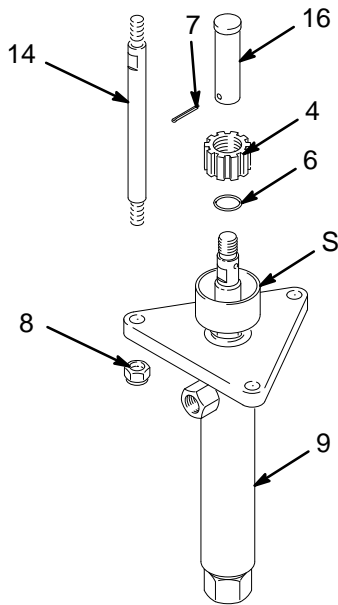

7594A

Manual Change Summary

This manual was electronically updated.

Dimensions

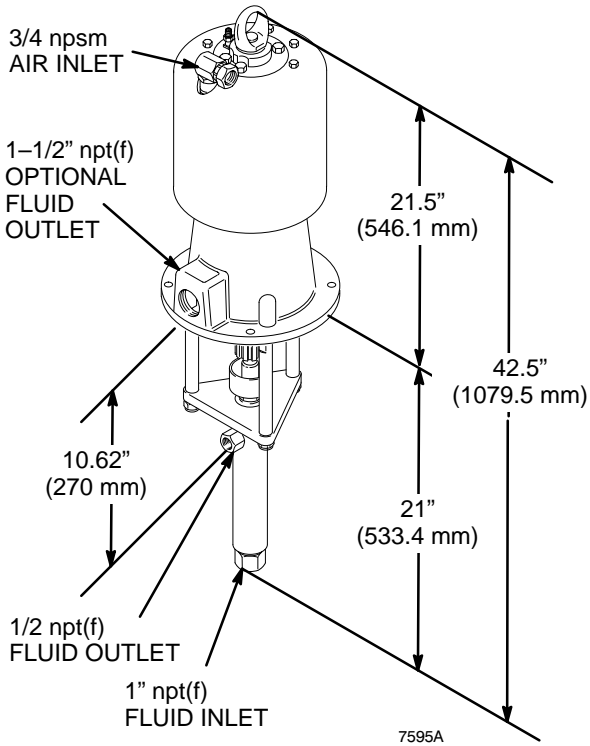

Mounting Hole Layout

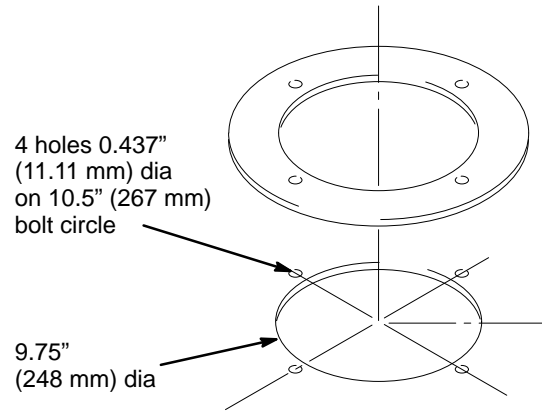

Technical Data

Category	Data
Ratio	35:1
Maximum Operating Air Pressure	120 psi (0.8 MPa, 8 bar)
Fluid Discharge Pressure	4200 psi (29.0 MPa, 290 bar)
Approx. Cycles per Gallon	40 (11 cycles per liter)
Air Consumption	Approx. 48 SCFM per gallon pumped at 100 psi (0.8 MPa, 8 bar)
Max. Recommended Pump Speed for Intermittent Operation	60 Cycles per minute
Max. Recommended Pump Speed For Continuous Operation	20 Cycles per minute
Air Inlet	3/4 npsm
Fluid Outlet	1/2 npt(f)
Weight	65 lb (29 kg)
Wetted Parts	See "Wetted Parts" in the displacement pump manual 307-650

Viton[®] is a registered trademarks of the Du Pont Company.

The Graco Warranty

Graco warrants all equipment listed in this manual which is manufactured by Graco and bearing its name to be free from defects in material and workmanship on the date of sale by an authorized Graco distributor to the original purchaser for use. With the exception of any special extended or limited warranty published by Graco, Graco will, for a period of twelve months from the date of sale, repair or replace any part of the equipment determined by Graco to be defective. This warranty applies only when the equipment is installed, operated and maintained in accordance with Graco's written recommendations.

This warranty does not cover, and Graco shall not be liable for general wear and tear, or any malfunction, damage or wear caused by faulty installation, misapplication, abrasion, corrosion, inadequate or improper maintenance, negligence, accident, tampering, or substitution of non-Graco component parts. Nor shall Graco be liable for malfunction, damage or wear caused by the incompatibility of Graco equipment with structures, accessories, equipment or materials not supplied by Graco, or the improper design, manufacture, installation, operation or maintenance of structures, accessories, equipment or materials not supplied by Graco.

This warranty is conditioned upon the prepaid return of the equipment claimed to be defective to an authorized Graco distributor for verification of the claimed defect. If the claimed defect is verified, Graco will repair or replace free of charge any defective parts. The equipment will be returned to the original purchaser transportation prepaid. If inspection of the equipment does not disclose any defect in material or workmanship, repairs will be made at a reasonable charge, which charges may include the costs of parts, labor, and transportation.

Graco's sole obligation and buyer's sole remedy for any breach of warranty shall be as set forth above. The buyer agrees that no other remedy (including, but not limited to, incidental or consequential damages for lost profits, lost sales, injury to person or property, or any other incidental or consequential loss) shall be available. Any action for breach of warranty must be brought within two (2) years of the date of sale.

GRACO MAKES NO WARRANTY, AND DISCLAIMS ALL IMPLIED WARRANTIES OF MERCHANTABILITY AND FITNESS FOR A PARTICULAR PURPOSE IN CONNECTION WITH ACCESSORIES, EQUIPMENT, MATERIALS OR COMPONENTS SOLD BUT NOT MANUFACTURED BY GRACO. These items sold, but not manufactured by Graco (such as electric motors, gas engines, switches, hose, etc.), are subject to the warranty, if any, of their manufacturer. Graco will provide purchaser with reasonable assistance in making any claim for breach of these warranties.

In no event will Graco be liable for indirect, incidental, special or consequential damages resulting from Graco supplying equipment hereunder, or the furnishing, performance, or use of any products or other goods sold hereto, whether due to a breach of contract, breach of warranty, the negligence of Graco, or otherwise.

FOR GRACO CANADA CUSTOMERS

The parties acknowledge that they have required that the present document, as well as all documents, notices and legal proceedings entered into, given or instituted pursuant hereto or relating directly or indirectly hereto, be drawn up in English. Les parties reconnaissent avoir convenu que la rédaction du présente document sera en Anglais, ainsi que tous documents, avis et procédures judiciaires exécutés, donnés ou intentés à la suite de ou en rapport, directement ou indirectement, avec les procédures concernées.

Graco Phone Number

TO PLACE AN ORDER, contact your Graco distributor, or call this number to identify the distributor closest to you:
1-800-367-4023 Toll Free.

*All written and visual data contained in this document reflects the latest product information available at the time of publication.
Graco reserves the right to make changes at any time without notice.*

Sales Offices: Minneapolis, Detroit, Los Angeles
Foreign Offices: Belgium, Canada, England, Korea, France, Germany, Hong Kong, Japan

GRACO INC. P.O. BOX 1441 MINNEAPOLIS, MN 55440-1441

PRINTED IN U.S.A. 307-648 June 1983, Revised August 1997