

Instructions – Parts List



1 HP (746 W) AIR MOTOR DRIVEN Outboard Agitator

306358G

100 psi (0.7 MPa, 7 bar) Maximum Working Pressure

Model 225831, Series B

Clamps to side of open 55 gallon drum



Important Safety Instructions

Read all warnings and instructions in this manual.
Save these instructions.

Table of Contents

Warnings	2
Installation	4
Operation	5
Service	6
Parts	7
Dimensional Drawing	9
Technical Data	9
Air Consumption Chart	9
Graco Standard Warranty	10
Graco Information	10

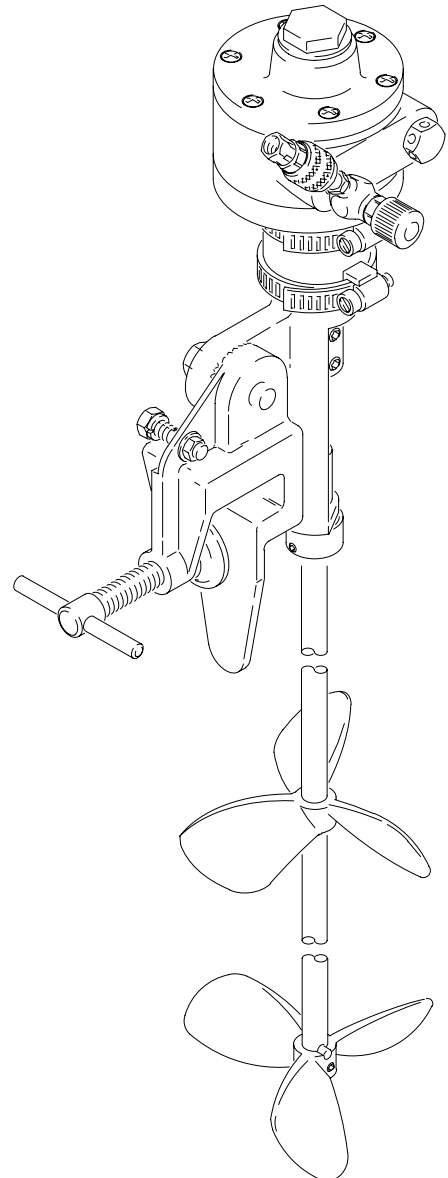

05382B

PROVEN QUALITY. LEADING TECHNOLOGY.

Symbols

Warning Symbol



This symbol alerts you to the possibility of serious injury or death if you do not follow the instructions.

Caution Symbol



This symbol alerts you to the possibility of damage to or destruction of equipment if you do not follow the instructions.

! WARNING



INSTRUCTIONS

EQUIPMENT MISUSE HAZARD

Equipment misuse can cause the equipment to rupture or malfunction and result in serious injury.

- This equipment is for professional use only.
- Read all instruction manuals, tags, and labels before operating the equipment.
- Use the equipment only for its intended purpose. If you are not sure, call Graco Technical Assistance at 1-800-328-0211.
- Do not alter or modify this equipment.
- Check equipment daily. Repair or replace worn or damaged parts immediately.
- Do not exceed the maximum working pressure of the lowest rated component in your system. This equipment has a **100 psi (0.7 MPa, 7 bar) maximum working pressure**.
- Use fluids and solvents which are compatible with the equipment wetted parts. Refer to the **Technical Data** section of all equipment manuals. Read the fluid and solvent manufacturer's warnings.
- Do not use 1,1,1-trichloroethane, methylene chloride, other halogenated hydrocarbon solvents or fluids containing such solvents with this equipment. Such use could result in a serious chemical reaction, with the possibility of explosion.
- Always wear protective eyewear, gloves, clothing, and respirator as recommended by the fluid and solvent manufacturer.
- Keep face away from the exhaust port.
- Comply with all applicable local, state, and national fire, electrical, and safety regulations.

WARNING



FIRE AND EXPLOSION HAZARD

Improper grounding, poor ventilation, open flames or sparks can cause a hazardous condition and result in a fire or explosion and serious injury.

- Ground the equipment and the object being sprayed. Refer to **Grounding** on page 4.
- If there is any static sparking or you feel an electric shock while using this equipment, **stop spraying immediately**. Do not use the equipment until you identify and correct the problem.
- Do not drive this equipment with combustible gases.
- Do not use kerosene or other flammable solvents.
- Provide fresh air ventilation to avoid the buildup of flammable fumes from solvents or the fluid being sprayed.
- Keep the spray area free of debris, including solvent, rags, and gasoline.
- Before operating this equipment, electrically disconnect all equipment in the spray area.
- Before operating this equipment, extinguish all open flames or pilot lights in the spray area.
- Do not smoke in the spray area.
- Do not turn on or off any light switch in the spray area while spraying or while there are any fumes in the air.
- Do not operate a gasoline engine in the spray area.
- Keep a fire extinguisher in the work area.



MOVING PARTS HAZARD

Moving parts, such as the rotating blades of the agitator, can pinch or amputate your fingers or other body parts and can cause splashing in the eyes or on the skin.

- Keep clear of all moving parts when starting or operating the agitator.
- Always shut off the agitator and disconnect the air line before adjusting the angle of the agitator, removing the agitator from the drum or checking or repairing any part of the agitator.

Installation

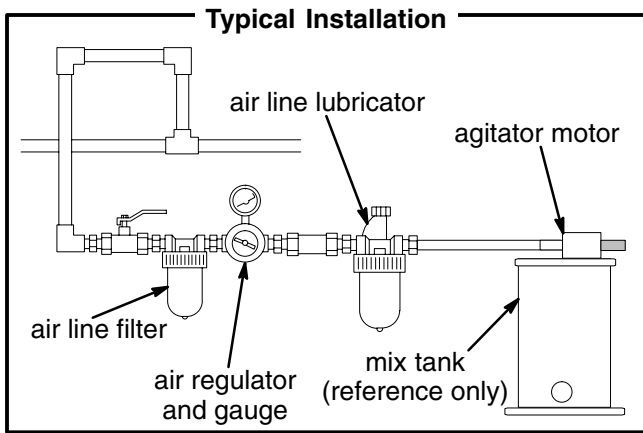

NOTE: The reference numbers and letters in parentheses in the text refer to Fig. 1, Fig. 2 and the Parts Drawing.

Grounding

Proper grounding is an essential part of maintaining a safe system.

To reduce the risk of static sparking, all electrically conductive objects or devices in the spray area **must** be properly grounded. Check your local electrical code for detailed grounding instructions for your area and type of equipment.

To ground the mixer:

Connect one end of the ground wire (B) to the mixer's ground connector (C). See Fig. 1. Connect the other end of the ground wire to a true earth ground. Order Part No. 237569, Ground Wire and Clamp.

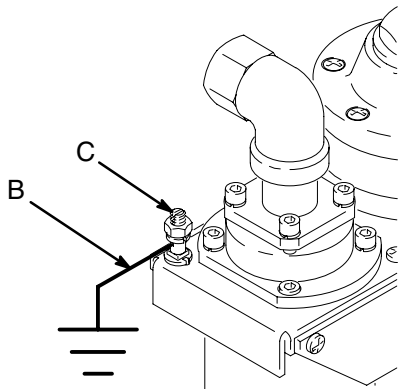

Fig. 1 03024

Air Requirements

For continuous use, the 1 HP motor typically requires 6 to 8 cfm (0.17 to 0.23 m³/min). Air consumption increases as the speed and air pressure is increased. See the **Air Consumption** graph on page 9.

Preparing the Agitator for Use

On the air line, install an **air line filter** to remove harmful dirt and moisture from the compressed air supply. Order Part No. 106148, 3/8 npt(f) or 106149, 1/2 npt(f).

⚠ CAUTION
Not lubricating the air motor will cause air motor failure.

Downstream from the filter, install an air line lubricator for automatic air motor lubrication. Set the lubricator feed rate at 1 drop of oil per minute for high speed or continuous duty usage. Do not overfeed oil or exhaust air may become contaminated. To manually lubricate the air motor, see **Lubricating the Air Motor** on page 6. To order a 3/8" npt air line lubricator, order Part No. 214847.

Mount the agitator on the edge of the drum or tank and securely tighten the clamp screw (3). See Fig. 2. To adjust the angle of the agitator in the drum, loosen the bracket screw (4). Adjust the agitator to the desired angle, then retighten the screw securely.

Connect the air supply hose between the 1/4 npt(f) inlet of the air line coupler (2) and the air supply line.

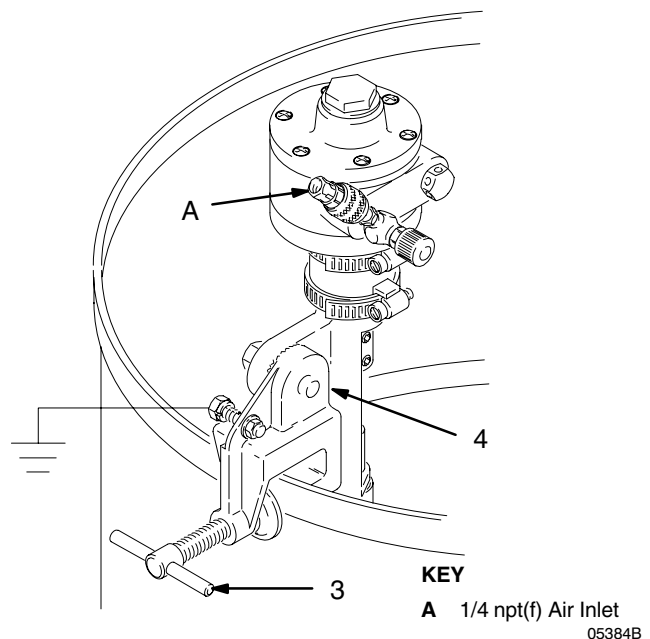

Fig. 2 05384B

Operation

Operating the Agitator

With the air supply on, snap the air line coupler (2) onto the fitting (14) in the air control valve (1). See the Parts Drawing. Use the air control valve to regulate the speed of the agitator. Always use the lowest speed necessary for thorough agitation of the fluid. Excessive speed may cause the fluid to foam.

Operate the agitator continuously while supplying fluid to the system.

Cleaning the Shaft

Each week, clean any dried fluid from around the bearing (18) and bracket (23) area of the shaft (21). See the Parts Drawing. Lubricate with several drops of light oil.

Service

Servicing

If the unit requires more than installation of a repair kit, it is usually quicker and least expensive to send the unit in for repair.

WARNING

To prevent explosive hazard do not drive this air motor with combustible gases. Injury and/or property damage can result.

Do not use kerosene or other combustible solvents.

Eye protection is **required**.

Keep face away from exhaust port and do not flush unit with flammable solvent.

Foreign material exiting the air motor can be hazardous.

CAUTION

Do not drive the air motor in excess of the recommended speeds.

Flushing

If the motor is sluggish or inefficient, try flushing with solvent.

The recommended solvent for air motors and lubricated pumps is Gast Flushing Solvent, Gast Part No. AH255 or AH255A, Loctite Safety Solvent, or Inhibisol Safety Solvent.

1. To flush a unit, disconnect the air line and muffler.

2. Add several teaspoons or spray solvent directly into the motor.
3. Rotate the shaft by hand in both directions for a few minutes.
4. Reconnect the air line and slowly apply pressure until there is no trace of solvent in the exhaust air.
5. Flush the unit in a well ventilated area.
6. Re-lubricate the motor with a squirt of oil in the chamber.

NOTE: If the vanes need replacing or foreign material is present in the motor chamber, an experienced mechanic may remove the end plate opposite the drive shaft end. Do not pry with a screwdriver. It will dent the surface of the plate and body, causing leaks.

A puller tool should be used which will remove the end plate while maintaining the position of the shaft. New vanes should have the edge with the corners cut on angle or the notched edge (if reversible) toward the bottom of the vane slot.

NOTE: Do not try to repair the air motor yourself. Contact a Graco distributor.

Lubricating the Air Motor

CAUTION

Not lubricating the air motor will cause air motor failure.

If an air line lubricator is not installed, the air motor must be manually lubricated every 8 hours. Lubricate the agitator air motor by placing 10–20 drops of SAE #10 light oil in the motor's air inlet. Run the agitator for about 30 seconds.

Parts

Model 225831

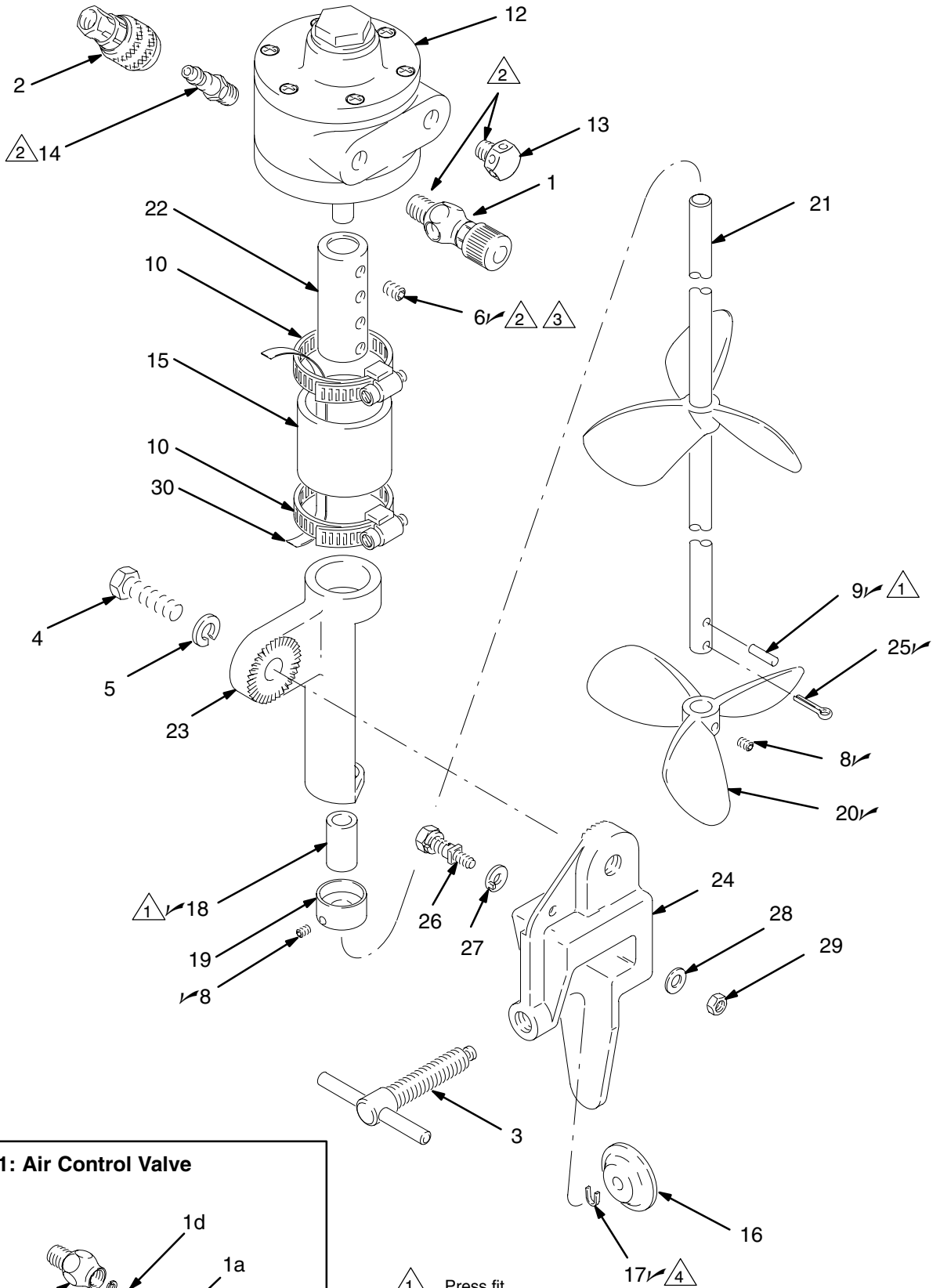

Ref. No. 1: Air Control Valve

0911B

- 1 Press fit.
- 2 Apply anaerobic pipe sealant to threads.
- 3 Torque to 96–132 in-lb (11–15 N.m).
- 4 Squeeze ends of retainer to set in place.

05383

Parts

Ref. No.	Part No.	Description	Qty.
1	206264	VALVE, needle <i>Includes items 18a to 18f</i>	1
1a	166529	.VALVE, needle	1
1b	166532	.NUT, packing	1
1c	164698	.KNOB, adjusting	1
1d	157628	.O-RING, packing	1
1e	165722	.BODY, valve	1
1f	166531	.WASHER	1
2	208536	COUPLER, air line	1
3	203399	SCREW, clamp	1
4	100017	SCREW, hex-hd cap; 1/2-13 x 1-1/2"	1
5	100018	LOCKWASHER; 1/2"	1
6✓	100053	SCREW, socket-hd set; 5/16-18 x 1/4"	4
7	100633	WRENCH; 5/16" (not shown)	1
8✓	101118	SCREW, socket-hd set; 10-24 x 1/4"	3
9✓	160077	PIN; 1/8" (3.2 mm) dia., 3/4" (19 mm) long	2
10	101368	CLAMP, hose; 2-1/8" dia.	2
11	101369	WRENCH; no. 10 (not shown)	1
12	101388	MOTOR, air; 1 HP (746 W)	1
13	156969	MUFFLER, air exhaust	1
14	169969	FITTING, air line	1
15	158865	COUPLING, rubber	1
16	159056	PAD, screw mounting	1
17✓	159057	RETAINER, pad	1
18✓	104391	BEARING, sleeve	1
19	159704	CUP, bearing protector	1
20✓	159854	PROPELLER	2
21	172311	SHAFT, agitator	1
22	159858	COUPLING, steel	1
23	159863	BRACKET, agitator	1
24	159864	MOUNTING, agitator	1
25✓	100579	PIN, cotter; 0.05" (1.2 mm) dia., 1" (25 mm) long	2
26	104029	LUG, ground	1
27	104582	WASHER, tab	1
28	100718	WASHER, star	1
29	110911	NUT, hex, M5	1
30	065251	WIRE, flat braid	3"

✓ *Keep these spare parts on hand to reduce down time.*

Dimensional Drawing

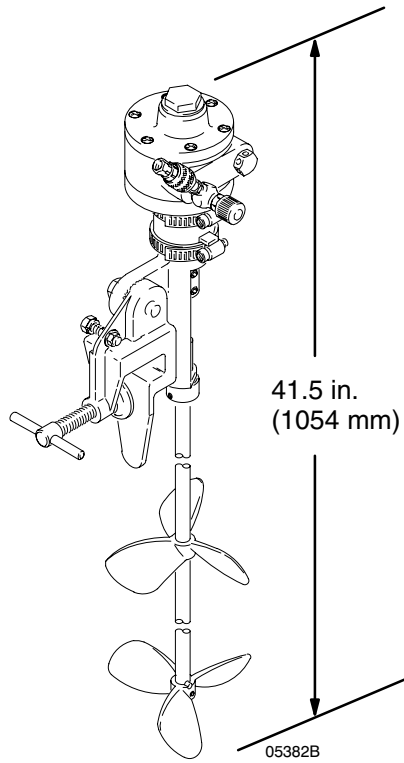

Technical Data

Maximum working pressure 100 psi (7 bar)
 Motor power rating 1 HP (746 W)
 Wetted parts Aluminum, Carbon Steel,
 Ductile Iron, Bronze

Length 41-1/2" (1054 mm)
 Weight 17 lb (7.7 kg)
 Air inlet size 1/4 npt(f)
 Air consumption See chart at right

*Noise Level @ 100 psi @ normal load
 @ 800 rpm: Pressure 77.0 dB(A)
 Power 86.1 dB(A)

*Noise Level @ 100 psi @ no load
 @ max rpm: Pressure 84.5 dB(A)
 Power 93.6 dB(A)

*Tested to CAGI-PNEUROP-1969

Air Consumption

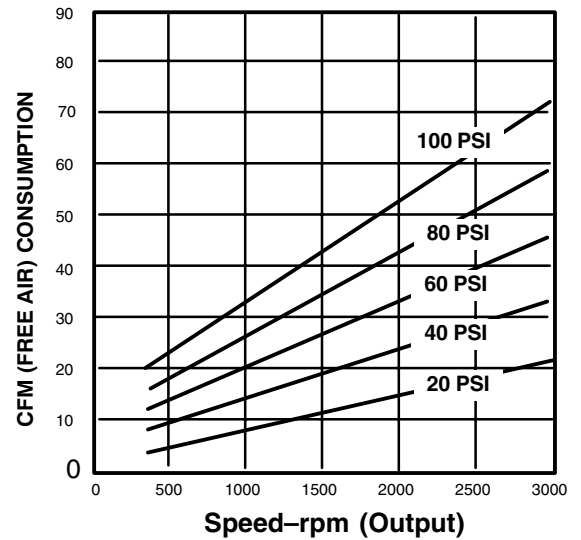

Graco Standard Warranty

Graco warrants all equipment manufactured by Graco and bearing its name to be free from defects in material and workmanship on the date of sale to the original purchaser for use. With the exception of any special, extended, or limited warranty published by Graco, Graco will, for a period of twelve months from the date of sale, repair or replace any part of the equipment determined by Graco to be defective. This warranty applies only when the equipment is installed, operated and maintained in accordance with Graco's written recommendations.

This warranty does not cover, and Graco shall not be liable for general wear and tear, or any malfunction, damage or wear caused by faulty installation, misapplication, abrasion, corrosion, inadequate or improper maintenance, negligence, accident, tampering, or substitution of non-Graco component parts. Nor shall Graco be liable for malfunction, damage or wear caused by the incompatibility of Graco equipment with structures, accessories, equipment or materials not supplied by Graco, or the improper design, manufacture, installation, operation or maintenance of structures, accessories, equipment or materials not supplied by Graco.

This warranty is conditioned upon the prepaid return of the equipment claimed to be defective to an authorized Graco distributor for verification of the claimed defect. If the claimed defect is verified, Graco will repair or replace free of charge any defective parts. The equipment will be returned to the original purchaser transportation prepaid. If inspection of the equipment does not disclose any defect in material or workmanship, repairs will be made at a reasonable charge, which charges may include the costs of parts, labor, and transportation.

THIS WARRANTY IS EXCLUSIVE, AND IS IN LIEU OF ANY OTHER WARRANTIES, EXPRESS OR IMPLIED, INCLUDING BUT NOT LIMITED TO WARRANTY OF MERCHANTABILITY OR WARRANTY OF FITNESS FOR A PARTICULAR PURPOSE.

Graco's sole obligation and buyer's sole remedy for any breach of warranty shall be as set forth above. The buyer agrees that no other remedy (including, but not limited to, incidental or consequential damages for lost profits, lost sales, injury to person or property, or any other incidental or consequential loss) shall be available. Any action for breach of warranty must be brought within two (2) years of the date of sale.

Graco makes no warranty, and disclaims all implied warranties of merchantability and fitness for a particular purpose in connection with accessories, equipment, materials or components sold but not manufactured by Graco. These items sold, but not manufactured by Graco (such as electric motors, switches, hose, etc.), are subject to the warranty, if any, of their manufacturer. Graco will provide purchaser with reasonable assistance in making any claim for breach of these warranties.

In no event will Graco be liable for indirect, incidental, special or consequential damages resulting from Graco supplying equipment hereunder, or the furnishing, performance, or use of any products or other goods sold hereto, whether due to a breach of contract, breach of warranty, the negligence of Graco, or otherwise.

FOR GRACO CANADA CUSTOMERS

The parties acknowledge that they have required that the present document, as well as all documents, notices and legal proceedings entered into, given or instituted pursuant hereto or relating directly or indirectly hereto, be drawn up in English. Les parties reconnaissent avoir convenu que la rédaction du présente document sera en Anglais, ainsi que tous documents, avis et procédures judiciaires exécutés, donnés ou intentés à la suite de ou en rapport, directement ou indirectement, avec les procédures concernées.

Graco Information

TO PLACE AN ORDER, contact your Graco distributor, or call one of the following numbers to identify the distributor closest to you:

1-800-328-0211 Toll Free

612-623-6921

612-378-3505 Fax

*All written and visual data contained in this document reflects the latest product information available at the time of publication.
Graco reserves the right to make changes at any time without notice.*

MM 306358

Graco Headquarters: Minneapolis

International Offices: Belgium, China, Japan, Korea

GRACO INC. P.O. BOX 1441 MINNEAPOLIS, MN 55440-1441

www.graco.com

PRINTED IN USA 306358 02/1952, Revised 05/2005